

Serving the Engine Building World since 1945

GOODSON

Tools and Supplies for Engine Builders



0059 (124.08)

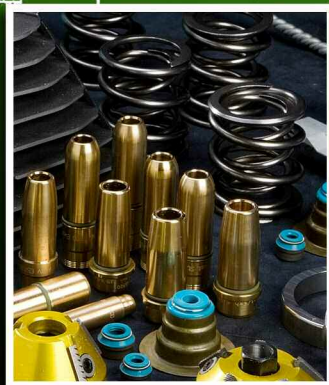
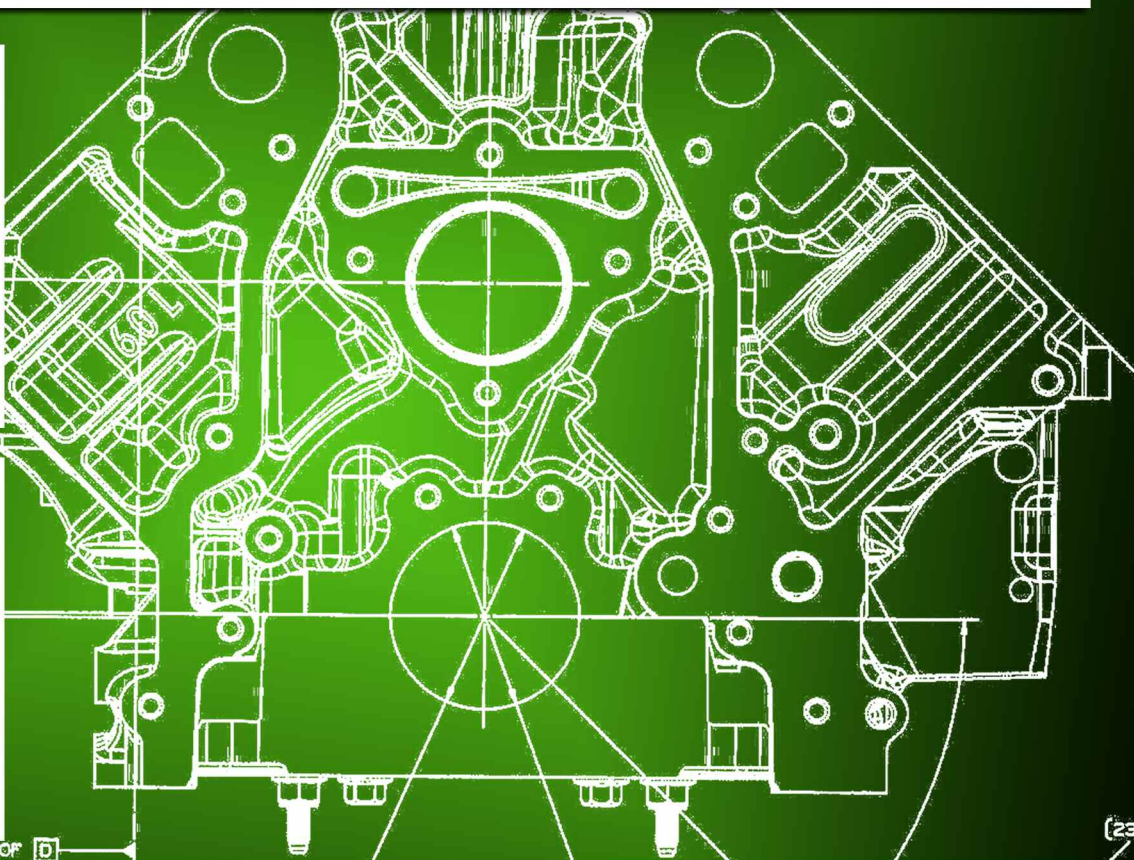

Toll-Free 800-533-8010 • Phone 507-452-1830 • www.goodson.com

From the President's Desk

Our thanks to all of our loyal customers who have been with us throughout the years. We look forward to serving your shop supply needs throughout 2012 and beyond.

Even though our industry is facing trying economic times, we continue to follow a course of action that was set in motion many years ago. This is the commitment to provide excellent and personal customer service, and to invest time and resources into providing top value products. This has been our business blueprint for many years and will continue to be for many more years.

“Our Promises to You” listed below are, and always have been, our core values.

To those of you who have ordered recently, our sincere Thanks! If you want to deal with a company that is committed to your needs and gives you **Full Service ... Fast!**, contact us today.

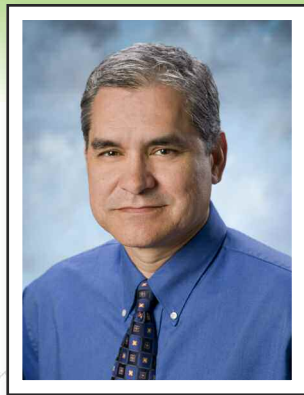

Juan Roque,
Goodson President



GOODSON Ironclad Guarantee

Goodson won't risk losing your business for any reason. If you're not 100% satisfied with your purchase, we'll fix it, exchange it or credit your account for the purchase price. To send an item back, simply include a note detailing the reason for the return and ship it back, freight pre-paid within 60 days. The only time we can't honor this guarantee is if a tool has been damaged through misuse or modification. All abrasives have a shelf life so we can only guarantee them for one year from the original purchase date.

Keep in touch

Sign up to receive emails from Goodson! We'll keep you up-to-date on technical information, special offers and much more. You can choose what information you want to receive and if you decide you don't want our email anymore you can take your name off the list quickly and easily. To find out more about our email program and get signed up, www.goodson.com/contact/subscribe.php.



Our Promises to You

- Same-day shipping
- Delivery in 3 days or less to the continental US
- Highest order fulfillment rate in the automotive aftermarket at 98.5%
- Customer Service Representatives available Monday - Friday, 7am to 7pm (Central time)
- No minimum order
- IRON-CLAD satisfaction guarantee
- Crankshaft grinding wheels made to order in-house
- Resetting and sharpening services available
- Secure online ordering at www.goodson.com
- Master Machinists on staff to answer your questions
- Spanish-speaking sales and service representatives on staff
- Worldwide shipping

Contact Us

Customer service representatives are available from 7am - 7pm, Mon. - Fri. and our Techxperts™ are on hand from 8am - 5pm, Mon. - Fri. (Central time)



Phone: 1-800-533-8010 (US & Canada)
1-507-452-1830 (International)
Fax: 1-888-466-3909 (US & Canada)
1-507-452-2907 (International)

Please note that the Goodson offices will be closed in observance of the following 2012 holidays: New Years Day (January 2), Memorial Day (May 28), Independence Day (July 4), Labor Day (September 3), Thanksgiving (November 22 & 23) and Christmas (December 25).

We're always open on the Web!

Web: www.goodson.com

Email: orderdesk@goodson.com



New from Goodson!



Heavy Duty Valve Seat Wheel Dresser For Large Diameter Stones

page 17



Pistol Grip Vacuum Tester with Replaceable Plates

page 45

Portable Surface Roughness Tester

page 44



Hydraulic Sleeve Installer

page 82



Magnetic Crack Detectors from Parker Industries

page 47

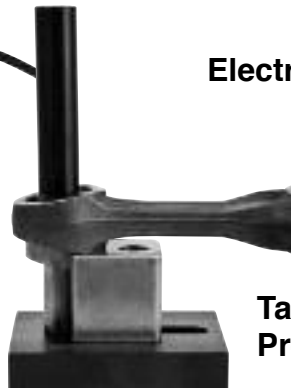

Tapered Wrist Pin Bushing Press Kit

page 83

G GOODTOOL
now exclusively from Goodson

GOODTOOL Brake Service Tools & Supplies are NOW AVAILABLE exclusively through GOODSON!

In a move to provide you with better pricing and a more complete selection of brake service tooling, **GOODSON** has acquired the product line of **GOODTOOL Brake Service Tools & Supplies**. These products are the same top quality you've come to expect from **GOODSON**. Due to the increased buying power, we are able to bring you these items at highly competitive pricing.

Check out the newly expanded **Brake and Alignment Tools** section starting on **page 110!**



Electric Rod Heater

page 87

Expanded Selection of Hard Parts for Off-Road Motorcycles, ATVs, Dirt Bikes and V-Twins

starting on page 126

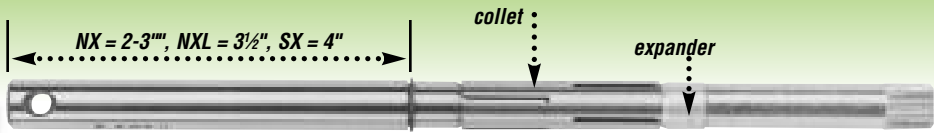

Expanding Pilots come with everything you need, including the Collet and Expander

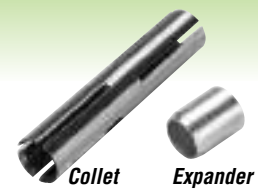

.020" / 51mm Range Expanding Pilots

Size	mm	Range	.297" / Std.	.297" Expander	.375" / Std.	.385" / Std.	.437" / Std.	Collets	Expanders	.375" / Long	Long Collet
.216"	5.5	.213"-.233"	P-1216NX	P-1216-EXP	P-5.5MMNX			P-216-COLLET	P-216-EXP		
.236"	6.0	.233"-.253"	P-1236NX	P-1236-EXP	P-6MMNX	P-6MMSX	P-6MMKX	P-6MM-COLLET	P-6MM-EXP		
.250"	6.3	.247"-.267"	P-1250NX	P-1250-EXP		P-250SX		P-250-COLLET	P-250-EXP		
.256"	6.5	.253"-.273"			P-6.5MMNX	P-6.5MMSX		P-65MM-COLLET	P-6.5MM-EXP		
.275"	7.0	.272"-.292"			P-7MMNX	P-7MMSX	P-7MMKX	P-7MM-COLLET	P-7MM-EXP		
.281"	7.1	.278"-.298"	P-1281NX	P-1281-EXP		P-281SX		P-281-COLLET	P-281-EXP		
.295"	7.5	.290"-.310"				P-7.5MMSX		P-281-COLLET	P-281-EXP		
.312"	7.9	.309"-.329"	P-1312NX	P-1312-EXP	P-312NX	P-312SX	P-312KX	P-312-COLLET	P-343-EXP	P-312NXL	P-312L-COL
.315"	8.0	.312"-.332"	P-1315NX	P-1315-EXP				P-312-COLLET	P-343-EXP		
.335"	8.5	.330"-.350"				P-8.5MMSX		P-343-COLLET	P-343-EXP		
.343"	8.7	.340"-.360"			P-343NX	P-343SX	P-343KX	P-343-COLLET	P-343-EXP	P-343NXL	P-343L-COL
.354"	9.0	.350"-.370"				P-9MMSX		P-375-COLLET	P-375-EXP		
.375"	9.5	.372"-.392"			P-375NX	P-375SX	P-375KX	P-375-COLLET	P-375-EXP	P-375NXL	P-375L-COL
.393"	10.0	.390"-.410"			P-10MMNX	P-10MMSX		P-10MM-COLLET	P-10MM-EXP		
.406"	10.3	.403"-.433"				P-406SX		P-10MM-COLLET	P-10MM-EXP	P-406NXL	P-406L-COL
.437"	11.0	.430"-.450"			P-11MMNX	P-11MMSX	P-11MMKX	P-11MM-COLLET	P-11MM-EXP		
.453"	11.5	.450"-.470"				P-453SX		P-11MM-COLLET	P-11MM-EXP		
.472"	12.0	.469"-.489"				P-12MMSX		P-12MM-COL	P-12MM-EXP		
.500"	12.7	.497"-.517"				P-500SX		P-12MM-COL	P-12MM-EXP	P-500NXL	P-500L-COL
Jobber			\$47.99	\$8.49	\$49.99	\$77.99	\$59.99	\$17.99	\$9.99	\$54.99	\$17.99

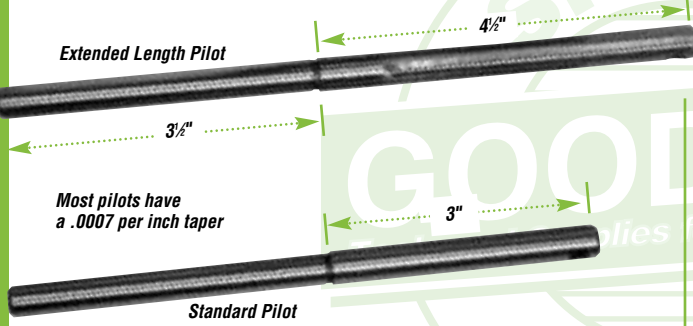

Extended Top Solid-Tapered High Speed Steel Pilots

Inch	mm	.375" Top	.385" Top	Inch	mm	.375" Top	.385" Top
.217"	5.51	P-5217NL		.314"	7.98	P-5314NL	P-5314SL
.218"	5.54	P-5218NL		.315"	8.00	P-5315NL	
.236"	6.00	P-5236NL		.316"	8.03	P-5316NL	
.237"	6.02	P-5237NL		.341"	8.66	P-5341NL	
.260"	6.60	P-5260NL		.342"	8.69	P-5342NL	
.261"	6.63	P-5261NL		.343"	8.71	P-5343NL	P-5343SL
.275"	6.98	P-5275NL	P-5275SL	.344"	8.74	P-5344NL	P-5344SL
.276"	7.00	P-5276NL	P-5276SL	.345"	8.77	P-5345NL	P-5345SL
.277"	7.04		P-5277SL	.346"	8.79		P-5346SL
.278"	7.06		P-5278SL	.372"	9.44		P-5372SL
.279"	7.08		P-5279SL	.373"	9.47	P-5373NL	P-5373SL
.310"	7.87	P-5310NL		.374"	9.50	P-5374NL	P-5374SL
.311"	7.90	P-5311NL		.375"	9.53	P-5375NL	P-5375SL
.312"	7.92	P-5312NL	P-5312SL	.376"	9.55	P-5376NL	
.313"	7.95	P-5313NL	P-5313SL	.382"	9.70	P-5382NL	
Jobber		\$57.99	\$89.99	Jobber		\$57.99	\$89.99

Tapered Carbide Pilots

Carbide pilots are preferred for many applications because they deflect less when under stress. Keep in mind that due to the brittle nature of carbide we can only warranty carbide pilots for size.

Inch	mm	.236" Top	.375" Top	Inch	mm	.236" Top	.375" Top
.156"	3.96	PCT-1560M		.256"	6.50	PCT-2560M	
.157"	3.98	PCT-1570M		.257"	6.53	PCT-2570M	
.1575"	4.00	PCT-1575M	PCT-1575	.258"	6.55	PCT-2580M	
.158"	4.01	PCT-1580M		.259"	6.58	PCT-2590M	
.176"	4.47	PCT-1760M		.260"	6.60	PCT-2600M	PCT-2600
.177"	4.50	PCT-1770M	PCT-1770	.2756"	7.00		PCT-2756
.178"	4.52	PCT-1780M		.276"	7.01	PCT-2760M	PCT-2760
.196"	4.98	PCT-1960M		.2765"	7.02		PCT-2765
.197"	5.00	PCT-1970M	PCT-1970	.277"	7.04	PCT-2770M	
.198"	5.03	PCT-1980M		.312"	7.93		PCT-3120
.216"	5.49	PCT-2160M		.315"	8.00		PCT-3150
.2165"	5.50		PCT-2165	.342"	8.70		PCT-3420
.217"	5.52	PCT-2170M	PCT-2170	.343"	8.72		PCT-3430
.218"	5.54	PCT-2180M		.344"	8.74		PCT-3440
.235"	5.97	PCT-2350M		.373"	9.47		PCT-3730
.2355"	5.98		PCT-2355	.374"	9.50		PCT-3740
.236"	5.99	PCT-2360M		.375"	9.53		PCT-3750
.2362"	6.00		PCT-2362	Jobber		\$199.99	\$199.99
.237"	6.02	PCT-2370M	PCT-2370				
Jobber		\$199.99	\$199.99				

.375" Top Serdi-Style Straight Carbide Pilots

mm	in	Order No.	mm	in	Order No.	mm	in	Order No.
3.99	.1571"	PCS-399	6.61	.2600"	PCS-661	8.01	.3154"	PCS-801
4.00	.1575"	PCS-400	6.99	.2752"	PCS-699	8.02	.3157"	PCS-802
4.01	.1579"	PCS-401	7.00	.2756"	PCS-700	8.70	.3425"	PCS-870
4.49	.1767"	PCS-449	7.01	.2760"	PCS-701	8.72	.3433"	PCS-872
4.50	.1771"	PCS-450	7.03	.2768"	PCS-703	8.73	.3437"	PCS-873
4.99	.1929"	PCS-499	7.04	.2771"	PCS-704	8.74	.3440"	PCS-874
5.00	.1964"	PCS-500	7.90	.3110"	PCS-790	9.45	.3720"	PCS-945
5.48	.2157"	PCS-548	7.91	.3114"	PCS-791	9.46	.3724"	PCS-946
5.50	.2165"	PCS-550	7.92	.3118"	PCS-792	9.47	.3728"	PCS-947
5.99	.2358"	PCS-599	7.93	.3122"	PCS-793	9.48	.3732"	PCS-948
6.00	.2362"	PCS-600	7.95	.3130"	PCS-795	9.49	.3736"	PCS-949
6.01	.2368"	PCS-601	7.99	.3146"	PCS-799	9.51	.3744"	PCS-951
6.50	.2559"	PCS-650	8.00	.3150"	PCS-800	9.52	.3748"	PCS-952
6.59	.2594"	PCS-659	Jobber		\$169.99	Jobber		\$169.99
Jobber		\$169.99						

Solid-Tapered High Speed Steel Pilots

- Fit all popular seat grinding or seat and guide machines

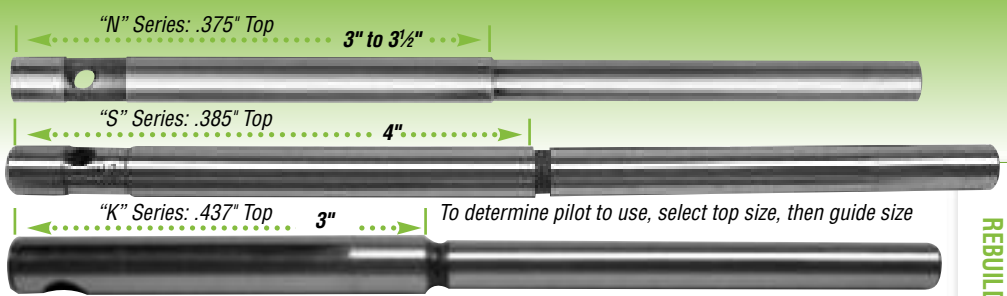

Pilot Size		Order Numbers for Top Sizes			
Inch	mm	.297"	.375"	.385"	.437"
.149"	3.78	P-1149N	—	—	—
.156"	3.96	—	—	P-5156S	—
.157"	3.98	—	—	P-5157S	—
.158"	4.01	P-1158N	—	P-5158S	—
.159"	4.04	P-1159N	—	—	—
.177"	4.50	P-1177N	P-5177N	P-5177S	P-5177K
.178"	4.52	P-1178N	—	—	—
.196"	4.98	—	P-5196N	P-5196S	P-5196K
.197"	5.00	P-1197N	P-5197N	P-5197S	P-5197K
.198"	5.02	P-1198N	P-5198N	P-5198S	P-5198K
.216"	5.50	P-1216N	P-5216N	P-5216S	P-5216K
.217"	5.51	P-1217N	P-5217N	P-5217S	P-5217K
.218"	5.54	—	P-5218N	P-5218S	P-5218K
.235"	5.97	—	P-5235N	P-5235S	P-5235K
.236"	6.00	P-1236N	P-5236N	P-5236S	P-5236K
.237"	6.02	P-1237N	P-5237N	P-5237S	P-5237K
.238"	6.04	P-1238N	P-5238N	P-5238S	P-5238K
.239"	6.07	—	P-5239N	—	—
.249"	6.32	P-1249N	P-5249N	—	P-5249K
.250"	6.35	P-1250N	P-5250N	P-5250S	P-5250K
.251"	6.37	P-1251N	P-5251N	P-5251S	P-5251K
.256"	6.50	—	P-5256N	—	—
.257"	6.53	—	P-5257N	—	—
.258"	6.55	—	P-5258N	P-5258S	P-5258K
.259"	6.58	—	—	P-5259S	P-5259K
.260"	6.60	P-1260N	P-5260N	P-5260S	P-5260K
.261"	6.63	—	—	P-5261S	P-5261K
.262"	6.66	—	—	P-5262S	—
.273"	6.93	—	P-5273N	P-5273S	P-5273K
.274"	6.96	—	—	P-5274S	—
.275"	6.98	P-1275N	P-5275N	P-5275S	P-5275K
.276"	7.00	—	—	P-5276S	P-5276K
.277"	7.04	—	P-5277N	P-5277S	P-5277K
.278"	7.06	—	P-5278N	P-5278S	P-5278K
.279"	7.08	—	P-5279N	P-5279S	P-5279K
.281"	7.14	P-1281N	—	—	—
.295"	7.50	—	P-5295N	—	—
Jobber		\$22.99	\$35.99	\$47.99	\$55.99

Pilot Size		Order Numbers for Top Sizes			
Inch	mm	.297"	.375"	.385"	.437"
.296"	7.52	—	P-5296N	—	—
.309"	7.85	—	P-5309N	—	—
.310"	7.87	—	P-5310N	P-5310S	P-5310K
.311"	7.90	—	P-5311N	P-5311S	P-5311K
.312"	7.94	P-1312N	P-5312N	P-5312S	P-5312K
.313"	7.95	P-1313N	P-5313N	P-5313S	P-5313K
.314"	7.98	—	P-5314N	P-5314S	P-5314K
.315"	8.00	P-1315N	P-5315N	P-5315S	P-5315K
.316"	8.03	—	P-5316N	P-5316S	P-5316K
.317"	8.05	—	—	P-5317S	P-5317K
.318"	8.08	—	—	P-5318S	P-5318K
.339"	8.61	—	P-5339N	—	—
.340"	8.64	—	P-5340N	P-5340S	—
.341"	8.66	—	P-5341N	P-5341S	P-5341K
.342"	8.69	—	P-5342N	P-5342S	P-5342K
.343"	8.71	P-1343N	P-5343N	P-5343S	P-5343K
.344"	8.74	—	P-5344N	P-5344S	P-5344K
.345"	8.77	—	P-5345N	P-5345S	P-5345K
.354"	9.00	—	P-5354N	P-5354S	P-5354K
.355"	9.02	—	—	P-5355S	—
.356"	9.04	—	—	P-5356S	—
.358"	9.09	—	P-5358N	P-5358S	P-5358K
.373"	9.47	—	P-5373N	P-5373S	P-5373K
.374"	9.50	—	P-5374N	P-5374S	P-5374K
.375"	9.53	—	P-5375N	P-5375S	P-5375K
.376"	9.55	—	P-5376N	P-5376S	—
.377"	9.58	—	P-5377N	—	—
.378"	9.60	—	P-5378N	P-5378S	—
.379"	9.63	—	P-5379N	P-5379S	P-5379K
.382"	9.70	—	P-5382N	P-5382S	—
.393"	9.98	—	—	P-5393S	—
.394"	10.00	—	P-5394N	P-5394S	P-5394K
.433"	11.00	—	P-5433N	P-5433S	—
Jobber		\$22.99	\$35.99	\$47.99	\$55.99
.500"	12.70	—	—	P-5500S	—
.501"	12.73	—	—	P-5501S	—
.502"	12.75	—	—	P-5502S	—
Jobber				\$79.99	

.572" Top Pilots For large diameter SX-1703 or OE Sioux™ 1703 Holders

In	mm	Order No.
.562"	14.27	P-5562S
.563"	14.30	P-5563S
.564"	14.33	P-5564S
.625"	15.88	P-5625S
.626"	15.90	P-5626S
.627"	15.92	P-5627S
.628"	15.95	P-5628S
Jobber		\$157.99

See page 16 for Stone Holder

.375 Top Black & Decker® Gruv-Top Pilots & Collets

- Replacement of discontinued OE
- 4"/101.6mm long top side with an extended spiral groove • .375" top
- Collets also fit OE pilots

Size	Pilots	Collets
.312"	P-312-BD	BD-312-COLLET
.343"	P-343-BD	BD-343-COLLET
.375"	P-375-BD	BD-375-COLLET
Jobber	\$129.99	\$37.99

.375" Top Split Leveling Pilots

- Centers deep in the valve guide
- Includes a groove for bearing-style stone holders • Compensates for wear up to .010" • .375" top size

Size	Range	Jobber	Order No.
5.0mm	.193"-.203"	\$174.99	P-5MM-VNX
5.5mm	.213"-.223"	159.99	P-5.5MM-VNX
6.0mm	.233"-.243"	149.99	P-6MM-VNX
.250"	.247"-.257"	159.99	P-250-VNX
7.0mm	.273"-.283"	149.99	P-7MM-VNX
.312"	.299"-.319"	129.99	P-312-VNX
8.0mm	.312"-.322"	149.99	P-8MM-VNX
.343"	.340"-.350"	129.99	P-343-VNX
9mm	.351"-.361"	149.99	P-9MM-VNX
.375"	.372"-.382"	129.99	P-375-VNX
.437"	.434"-.444"	129.99	P-437-VNX

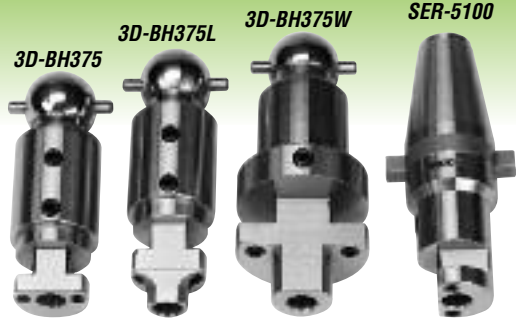

3-D Fast Cut™ Starter Kits

- Can be used with your existing pilots • Ball heads are available to fit most common seat grinder pilots • Choose from over 100 3-angle blade profiles on pages 6-7
- Fully compatible with most popular 3-angle cutting systems including Kwik-Way, Peterson, Rottler, Serdi, Sunnen, T&S, Winona Van Norman, Newen, etc.

Description	Fits Pilot	Jobber	Order No.	Includes
Fits Pilot Size	.375" / 9.53mm	\$799.99	3D-375-KIT	
(see page 3 for our selection of pilots)	.385" / 9.78mm	799.99	3D-385-KIT	
	.390" / 9.90mm	799.99	3D-390-KIT	
	.437" / 11.10mm	799.99	3D-437-KIT	
Ball Head Standard	.375" / 9.53mm	154.99	3D-BH375	x
3/8" channel fits most	.385" / 9.78mm	154.99	3D-BH385	x
3-angle systems such as Serdi, WVN, KW, etc.	.390" / 9.90mm	189.99	3D-BH390	x
	.437" / 11.10mm	154.99	3D-BH437	x
Ball Head Wide Body	.375" / 9.53mm	274.99	3D-BH375W	
4.0625" long	.385" / 9.78mm	299.99	3D-BH385W	
Ball Head Extended	.375" / 9.53mm	184.99	3D-BH375L	
Length 3.80" long	.385" / 9.78mm	184.99	3D-BH385L	
Serdi-Style Tool Bodies	Use with Serdi-style pilots (page 2)			
4" long	Standard .375" / 9.53mm	269.99	SER-5100	
	Large Body .375" / 9.53mm	339.39	SER-5300	
Tip Holders	.709" - 1.181" / 18-30mm	139.99	3D-2000	x x x x
	1.02" - 1.653" / 26-42mm	139.99	3D-2001	x x x x
	1.575" - 2.362" / 40-60mm	139.99	3D-2002	x x x x
Tip Holders-Wide Body	1.575" - 2.362" (40mm-60mm)	216.99	3D-2003	
	2.385" - 3.150" (58mm-80mm)	216.99	3D-2004	
Cutters	45°/1.0mm	29.99	FT-45039V1	x x x x
	45°/1.3mm	29.99	FT-45051V1	x x x x
	45°/1.5mm	29.99	FT-45059V1	x x x x
	45°/1.9mm	29.99	FT-45075V1	x x x x
Tool Setting Fixture		119.99	3D-TSFA	x x x x
Cutter Blade Mounting Screw		4.99	FT-SCREW	x x x x
Blade Wrench		8.79	FT-WRENCH	x x x x
Automotive Spring Set (4 Pc.)		25.29	3D-SS4	x x x x
Bushing Set (1 pair)	.375"	8.99	3D-DB7	
	.385"	8.99	3D-DB6	x x
	.437"	8.99	3D-DB5	x
Ball Head	#3 Morse Taper Driver	289.99	3D-CM3	
Drive Adaptors	#4 Morse Taper Driver	299.99	3D-CM4	
	Bridgeport & DCM Driver	249.99	3D-3/4SS	
	Sunnen Early Style Driver	269.99	3D-SUN	
3-D Fast Cut™ Accessories				
Lift Clip for Spring Pad Cutters (page 8)		\$ 22.99	3D-CLIP	
Replacement 1/8" Hex Key		1.29	3D-1/8	x x x x
Replacement 2.5mm Hex Key		1.29	3D-2.5	x x x x
Replacement 3/8" Hex Key		1.29	3D-3/32	x x x x
Replacement Screws for NWN Ball Head Base (5) - metric		5.99	MGA-4X5MM	
Replacement Screw for 3D Ball Head Base - SAE 10x32		3.99	3D-BH1032	
Adjusting Screw for Holder #3D-2000, OAL: .395" (10mm)		3.99	3D-2000-S	
Adjusting Screw for Holder #3D-2001, OAL: .475" (12mm)		3.99	3D-2001-S	
Adjusting Screw for Holder #3D-2002, OAL: .625" (15.9mm)		3.99	3D-2002-S	

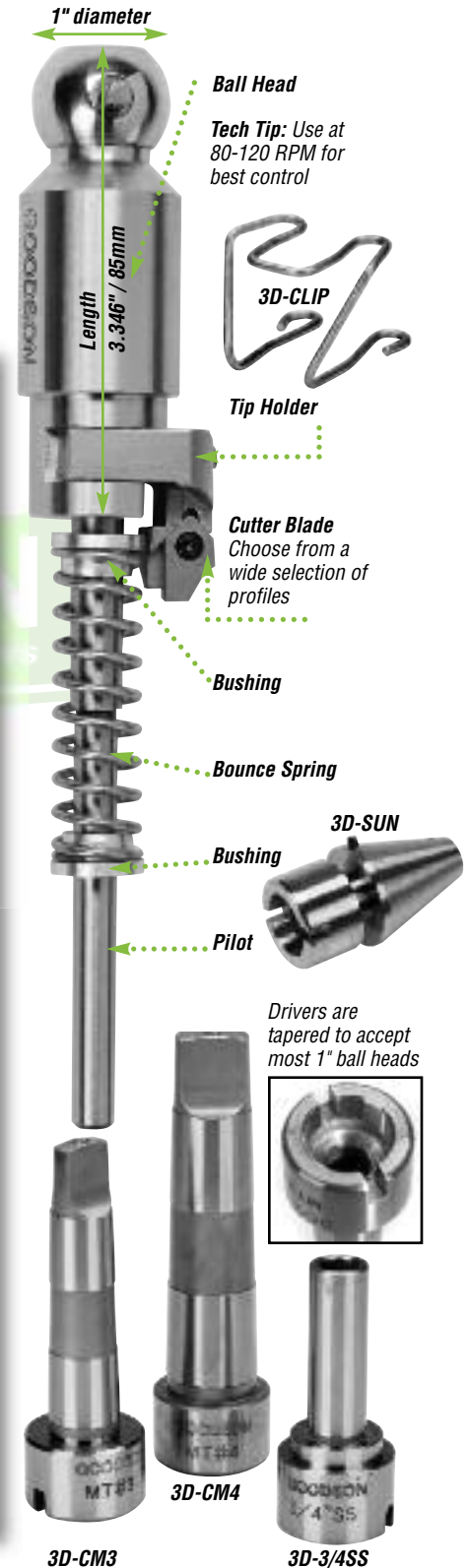

See page 5 for our Valve Seat Removal Tooling for the 3-D Fast Cut™ System

3D-CM3 3D-CM4 3D-3/4SS

3-D Fast Cut™

3-D Fast Cut™ System Micro Ball Head Tooling

- Fits the same 1" ball head driver
- Requires .236" pilot (page 2)

Description	Jobber	Order No.
3D Ball Head for .236"/6mm Pilot (2.56"L)	\$149.99	3D-BH236
Tip Holder .551"-.850" Range	139.99	3DH-1999M
Bounce Springs Short	1.050" / 26.7mm	9.99 3D-BS1
.340" ID Medium	1.540" / 39.2 mm	9.99 3D-BS3
.420" OD Long	2.550" / 64.8 mm	9.99 3D-BS2
Bounce Spring Bushing	6.99	3D-BB1
Bounce Spring Spacer, 22mm long	24.99	3D-BB2
Tool Setting Fixture	119.99	3D-TSFA

3-D Fast Cut Setting Micrometers

- Accurate to .0005" / .013mm
- Standard micrometer uses .375" Pilot (sold separately)
- Micro micrometer uses .236" Pilot (sold separately) (page 2)

Description	Jobber	Order No.
Standard Micrometer	\$199.49	MGA-MIC
Standard	27.99	MGA-MIC-1S
90° Cutter	29.99	FT-90
90° Cutter	29.99	FT-9020B-HP

- Micro micrometer uses .236" Pilot (sold separately) (page 2)

Description	Jobber	Order No.
Micro Micrometer	\$199.99	3DM-236
90° Micro Cutter	49.99	FTM-190

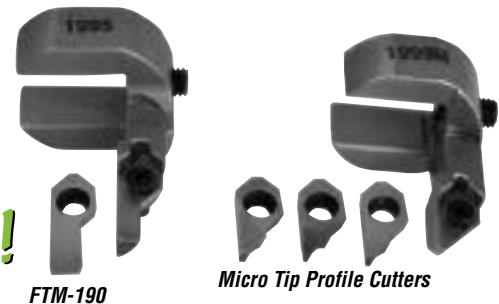
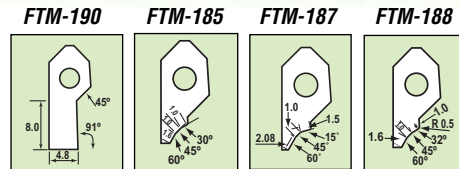
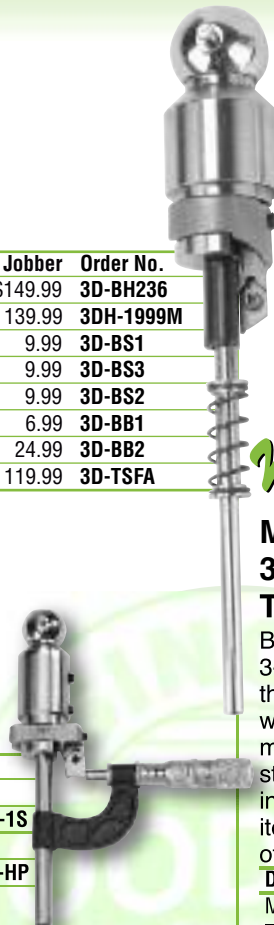

Micro 3-D Fast Cut™ Tooling

Based on the standard 3-D Fast Cut™ tooling, these holders and cutters have been modified to work on small heads such as Honda. Tip Holders have been modified to fit inside the smaller seats without sacrificing strength. Most Goodson 3-D Fast Cut™ tooling is interchangeable but due to the modifications made to these items, they are **NOT** interchangeable with standard sizes or other systems.

Description	Jobber	Order No.
Micro	.551"-.850" Range	\$169.99 3DH-1995*
Tip Holders	.550"-.984" Range	139.99 3DH-1999M
Micro	see profile above	49.99 FTM-185
Cutters	see profile above	49.99 FTM-187
fit holders	see profile above	49.99 FTM-188
above	see profile above	49.99 FTM-190*
Micro Tooling 3D Micrometer	199.99	3DM-236

*FTM-190 cutter will fit 3DH-1995 Holder only

Valve Seat Removal Tooling

- Fits most popular 3-angle cutting tools including our popular 3-D Fast Cut™ System, Kwik-Way, Peterson, Rottler, Serdi, T&S, Winona Van Norman, Newen, etc.
- Use to relieve press fit for easier seat removal
- Requires a minimum of two cuts
- For precise set up use **MGA-MIC**
- Tip Holders include one cutting tip (**3DB-1999i** or **3DB-250**) and mounting screw
- Replacement tips and screws sold separately
- Ball Head and Drive Tools sold separately (see page 4)

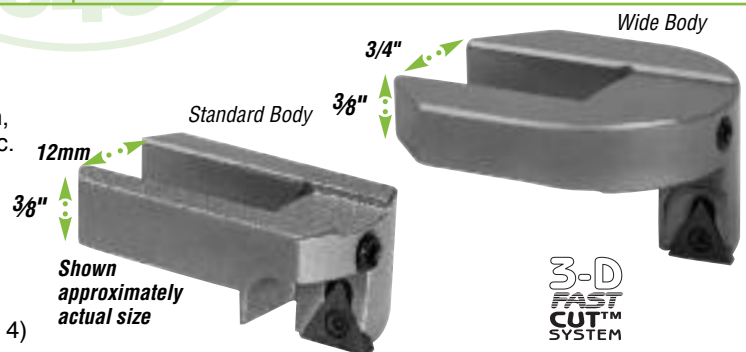

Description	Replacement Tip	Jobber	Order No.	Cutting Range with Pilot Size			
				.236" Top Pilot	.375" Top Pilot	.385" Top Pilot	.437" Top Pilot
Tip Holders	3DB-1999i	\$199.99	3D-1999C	0.960" - 1.225"	1.095" - 1.360"	1.105" - 1.360"	1.157" - 1.360"
	3DB-250	199.99	3D-2000C	1.056" - 1.480"	1.194" - 1.480"	1.206" - 1.480"	1.264" - 1.480"
	3DB-250	199.99	3D-2001C	_____	1.376" - 2.000"	1.386" - 2.000"	1.450" - 2.000"
	3DB-250	199.99	3D-2002C	_____	1.524" - 2.460"	1.544" - 2.460"	1.610" - 2.460"
	3DB-250	269.99	3D-2003C	_____	1.680" - 2.400"	1.680" - 2.400"	_____
	3DB-250	269.99	3D-2004C	_____	2.280" - 3.200"	2.280" - 3.200"	_____
Replacement Tip	Fits 3D-1999C Holder	30.99	3DB-1999i				
Replacement Tip	Fits 3D-2000C-2004C Holders	30.99	3DB-250				
Replacement Mounting Screws	for 3DB-1999i	10.99	3DB-1999S				
	for 3DB-250	10.99	3DS-SCREW				

For more information on how the Valve Seat Removal Tooling works, visit our website at: www.goodson.com/seat_removal



Mondello Signature Series Cutter Blades

Add 10 to 20 CFM to cylinder heads with Mondello Signature Series Valve Seat Cutter Blades

Industry legend, Joe Mondello passed away suddenly in 2011, but his legacy lives on in the Valve Seat Cutter Blades that bear his name. Mondello's expertise in reworking cylinder heads are built into these cutters. Designed to increase airflow by as much as 20 CFM, these cutters are intended for certain applications. Generally you should use intake cutters on intakes and exhaust on exhaust, but as with most things, there's always an exception. Experiment to find the right combination for you and your customers.

You'll find a wide range of profiles in the Mondello Signature Series Cutters because every head and application is unique. Mondello Signature Series Cutters are affordable enough to allow you to do just that. Need help getting started? Talk to one of our Techxerts™ at **1-800-533-8010**.

Illustrations enlarged to show detail.

	Profile	Seat Width		Order No.
Intake	39°/45°/60°	.043"	1.1mm	IFT-4539B-HP
	30°/45°/60°	.043"	1.1mm	IFT-4560-HD
	39°/45°	.071"	1.8mm	IFT-4524A-HD
	75°	—	—	IFT-75R6B-HP
	30°/45°/60°	.067"	1.7mm	IFT-45B-HP
	39°/45°	.067"	1.7mm	IFT-4522B-HP
	30°/45°/60°	.047"	1.2mm	IFT-4560B-HP
	39°/45°	.067"	1.7mm	IFT-4529B-HP
	39°/45°/60°	.059"	1.5mm	IFT-4560A-HD
	21°/30°/45°	.047"	1.2mm	IFT-30B-HP
	46°/50°/67°/75°	.043"	1.1mm	IFT-5065B-HP
	35°/45°	.059"	1.5mm	KFT-3545
	37°/45°	.059"	1.5mm	KFT-3745
	46°/50°/65°/75°	.078"	2.0mm	EFT-5046B-HP
	45°/50°/60°/70°	.080"	2.03mm	EFT-5060B-HP
45°/50°/60°/70°	.080"	2.03mm	EFT-5061B-HP	
50°/55°/65°/75°/80°	.078"	2.0mm	EFT-5550B-HP	
50°/55°/65°/80°	.069"	1.75mm	EFT-5565B-HP	
48°/55°/67°/77°/80°	.070"	1.78mm	EFT-5567B-HP	
Exhaust	39°/45°	.055"	1.4mm	IFT-4524-HD
	39°/45°/56°/21°	.039"	1.0mm	IFT-4556B-HP
	47°/50°	.051"	1.3mm	IFT-5025B-HP
	5°/10°/20°/47°	.059"	1.5mm	KRT-447
	10°/20°/35°/47°	.059"	1.5mm	KRT-647
Specialty	15°	—	—	IFT-1556-HD
	82°	—	—	IFT-82R6B-HP
	86°	—	—	IFT-86RB-HP
	10°	—	—	IFT-1056-HD
	15°	—	—	IFT-1543-HD
	10°	—	—	IFT-1043-HD
	39°/45°	.059"	1.5mm	KFT-3945
	49°/55°/Profile	.059"	1.5mm	EFT-5557B-HP
Radius Bowl Profiler for Exhaust Only				RBP-RR4
Jobber				\$39.99 each

For an excellent article about the creation and use of the Mondello Signature Series Valve Seat Cutters, see **Engine Builder Magazine** August 2008 or read it online at <http://www.goodson.com/mondello> For a direct link, scan this code with your Smart Phone.



 IFT-4539B-HP	 IFT-4560-HD	 IFT-4524A-HD	 IFT-75R6B-HP
 IFT-45B-HP	 IFT-4522B-HP	 IFT-4560B-HP	 IFT-4529B-HP
 IFT-4560A-HD	 IFT-30B-HP	 IFT-5065B-HP	 KFT-3545
 KFT-3745	 EFT-5046B-HP	 EFT-5060B-HP	 EFT-5061B-HP
 EFT-5550B-HP	 EFT-5565B-HP	 EFT-5567B-HP	 IFT-4524-HD
 IFT-4556B-HP	 IFT-5025B-HP	 KRT-447	 KRT-647
 IFT-1556-HD	 IFT-82R6B-HP	 IFT-86RB-HP	 IFT-1056-HD
 IFT-1543-HD	 IFT-1043-HD	 KFT-3945	 EFT-5557B-HP
 RBP-RR4	<h2>Create your own Cutter Sets!</h2> <p>Buy 10 or more, SAVE 10% Order any combination of cutters (mix or match) and save off jobber PLUS get the Cutter Storage Rack (FT-RACK) at half price!</p>		

All blades are enlarged to show detail

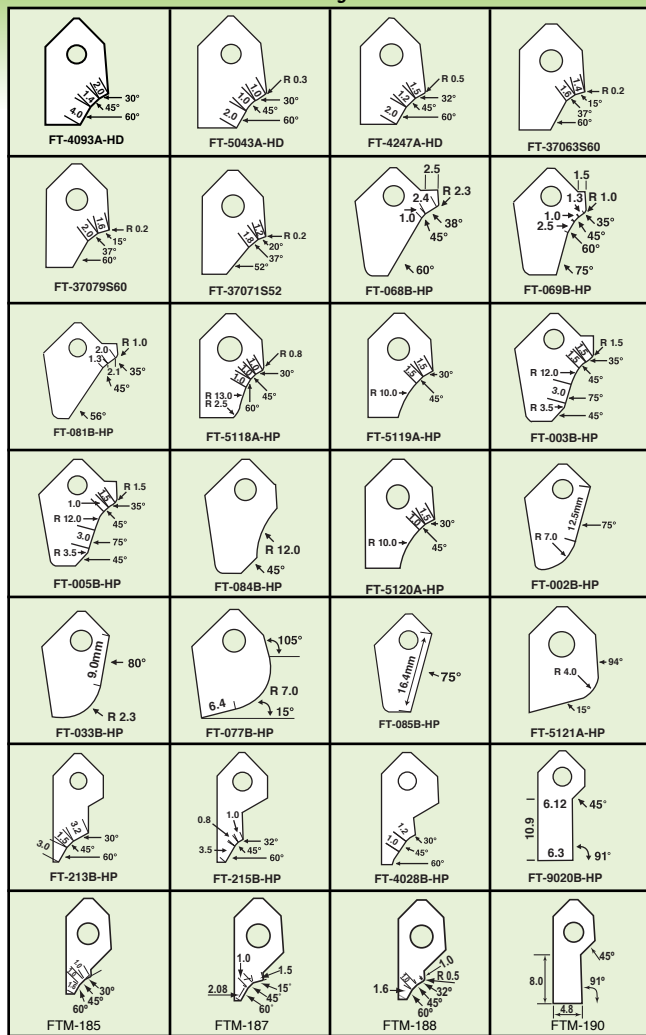

Radius Cutter Profile Valve Seat Cutters

Application	Profile	Seat Width	Jobber	Order No.	
Intake	30°/45°/60°	.055" 1.4mm	\$29.99	FT-4093A-HD	
	see drawing	.039" 1.0mm	29.99	FT-5043A-HD	
	see drawing	.047" 1.2mm	29.99	FT-4247A-HD	
	15°/37°/60°	.063" 1.6mm	29.99	FT-37063S60	
	15°/37°/60°	.079" 2.0mm	29.99	FT-37079S60	
	20°/37°/52°	.071" 1.8mm	29.99	FT-37071S52	
	38°/45°/60°	.039" 1.0mm	29.99	FT-068B-HP	
	35°/45°/60°/75°	.039" 1.0mm	29.99	FT-069B-HP	
	35°/45°/56°	.050" 1.3mm	29.99	FT-081B-HP	
	see drawing	.039" 1.0mm	29.99	FT-5118A-HP	
	see drawing	.059" 1.5mm	29.99	FT-5119A-HP	
	Exhaust	see drawing	.059" 1.5mm	\$29.99	FT-003B-HP
		see drawing	.039" 1.0mm	29.99	FT-005B-HP
		see drawing	—	29.99	FT-084B-HP
see drawing		.039" 1.0mm	29.99	FT-5120A-HP	
Specialty	see drawing	—	\$29.99	FT-002B-HP	
	see drawing	—	29.99	FT-033B-HP	
	see drawing	—	29.99	FT-077B-HP	
	see drawing	—	29.99	FT-085B-HP	
	see drawing	—	29.99	FT-5121A-HP	
Small Diameter	30°/45°/60°	.059" 1.5mm	\$29.99	FT-213B-HP	
	see drawing	.032" 0.8mm	29.99	FT-215B-HP	
	see drawing	.039" 1.0mm	29.99	FT-4028B-HP	
.358" W	90° extended	— Ideal for Alum.	29.99	FT-9020B-HP	
Micro	30°/45°/60°	.039" 1.0mm	\$49.99	FTM-185	
	15°/45°/60°	.059" 1.5mm	49.99	FTM-187	
Tool Holders on page 5	32°/45°/60°	.039" 1.0mm	49.99	FTM-188	
	90° extended	—	49.99	FTM-190	

Valve Seat Cutter Rack

- Measures: 17"x13 1/2"x1/4"
- Wall mount • L-hooks included
- Spaces for each stock cutter plus several blank spaces
- Order No. **FT-RACK**
- Jobber \$72.99

Buy 10 or more FT-cutters (any combination) and get the FT-RACK at half off jobber



3-D Valve Seat Cutters

- Fit all popular 3-angle seat cutting systems



3-ANGLE PROFILE CUTTERS Jobber \$29.99 each

Main Angle	Seat Width Inches	Seat Width mm	Top Angle	Top Width Inches	Top Width mm	Throat Angle	Order No.					
45°	.039"	1.0mm	25°	.055"	1.4mm	60°	FT-45039U1					
			25°	.071"	1.8mm	60°	FT-45039U2					
			30°	.047"	1.2mm	60°	FT-45039V1					
			35°	.063"	1.6mm	52°	FT-45039W1					
			35°	.063"	1.6mm	55°	FT-45039W2					
			35°	.063"	1.6mm	60°	FT-45039W3					
	.051"	1.3mm	30°	.039"	1.0mm	60°	FT-45051V2					
			30°	.047"	1.2mm	60°	FT-45051V4					
			30°	.079"	2.0mm	60°	FT-45051V1					
			30°	.079"	2.0mm	52°	FT-45051V3					
			37°	.079"	2.0mm	52°	FT-45051X1					
			37°	.079"	2.0mm	52°	FT-45051X1					
.055"	1.4mm	30°	.039"	1.0mm	60°	FT-45055V1						
		.059"	1.5mm	30°	.071"	1.8mm	60°	FT-45059V1				
				30°	.055"	1.4mm	60°	FT-45059V2				
				30°	.079"	2.0mm	60°	FT-45059V3				
				37°	.079"	1.8mm	52°	FT-45059X1				
				.063"	1.6mm	25°	.055"	1.4mm	60°	FT-45063U1		
25°	.071"					1.8mm	60°	FT-45063U2				
30°	.039"	1.0mm	60°			FT-45063V1						
30°	.047"	1.2mm	60°			FT-45063V3						
30°	.071"	1.8mm	52°			FT-45063W1						
30°	.079"	2.0mm	60°			FT-45063V2						
.071"	1.8mm	30°	.063"	1.6mm	60°	FT-45071V1						
		.075"	1.9mm	30°	.031"	0.8mm	52°	FT-45075V2				
				30°	.079"	2.0mm	60°	FT-45075V1				
				.079"	2.0mm	25°	.055"	1.4mm	60°	FT-45079U1		
						25°	.071"	1.8mm	60°	FT-45079U2		
						30°	.047"	1.2mm	60°	FT-45079V1		
30°	.079"					2.0mm	60°	FT-45079V1				
.098"	2.5mm	25°	.055"			1.4mm	60°	FT-45098U1				
		25°	.071"			1.8mm	60°	FT-45098U2				
		30°	.039"	1.0mm	20°	.063"	1.6mm	52°	FT-30039T1			
					15°	.039"	1.0mm	45°	FT-30051S1			
					15°	.071"	1.8mm	60°	FT-30059S1			
					15°	.079"	2.0mm	60°	FT-30059S3			
.063"	1.6mm				15°	.079"	2.0mm	45°	FT-30063S1			
					.071"	1.8mm	15°	.055"	1.4mm	60°	FT-30071S1	
		.075"	1.9mm	15°			.039"	1.0mm	45°	FT-30075S1		
				.079"			2.0mm	15°	.055"	1.4mm	60°	FT-30079S1
								15°	.071"	1.8mm	60°	FT-30079S2
								.098"	2.5mm	15°	.071"	1.8mm
15°	.079"									2.0mm	60°	FT-30098S2

1-ANGLE STRAIGHT CUTTERS Jobber \$29.99 each

Angle	Order No.	Angle	Order No.
15° straight	FT-15	55° straight	FT-55
20° straight	FT-20	60° straight	FT-60
30° straight	FT-30	65° straight	FT-65
35° straight	FT-35	70° straight	FT-70
37° straight	FT-37	75° straight	FT-75
39° straight	FT-39	82° straight	FT-82
45° straight	FT-45	90° straight	FT-90
50° straight	FT-50	5mm radius	FT-R5

CUTTER BLADE ACCESSORIES

Description	Jobber	Order No.
Mounting Screw	\$4.99	FT-SCREW
Blade Wrench	8.79	FT-WRENCH

Visit www.goodson.com to see cutter profiles

CYLINDER HEAD REBUILDING
CLEANING, ASSEMBLY & SAFETY
SHORT BLOCK REBUILDING
FLYWHEEL GRINDING
CRANKSHAFT/ BRAKE & ALIGNMENT TOOLS
MEASURING TOOLS
OFFROAD BIKE, ATV HARD PARTS
V-TWIN HARD PARTS



Use your 3-Angle Cutting System to Cut Spring Pads with our 3-D Fast Cut Universal Spring Pad Cutters

- Works with all popular 3-angle cutting systems
- Square blades are indexable and replaceable
- Tool holder includes one blade

Tool Holders			
Blade Size	Application	Jobber	Order No.
3/8" / 9.53mm	All except Sunnen®	\$159.99	SPC-375
1/2" / 12.70mm	All except Sunnen®	159.99	SPC-500
Sunnen Drive Adaptor		269.99	3D-SUN
3/8" / 9.53mm	Sunnen®	164.99	SUN-375
Lift Clip (fit all except OE Sunnen®)		22.99	3D-CLIP
Replacement Carbide Cutters (for all holder styles above)			
3/8" / 9.53mm		\$ 16.79	SPCI-375
1/2" / 12.70mm		16.79	SPCI-500



PROBLEM: I use a Sunnen® seat and guide machine. I'm having trouble controlling the spring pad cutting process. What do you have that will help?

SOLUTION: Goodson has designed a drive adaptor specifically for Sunnen® seat and guide machines with early style tooling. With the OE Sunnen® tooling, there is no way to hold back on the cut. The design of our 3D-SUN drive adaptor incorporates a groove in the drive adaptor so you can use the 3D-CLIP to connect the drive adaptor and the ball head for positive control. It moves when you do.

3D-SUN



Buy 6 or more cans of Cutting & Tapping Fluid and SAVE 10% off Jobber



Cut through even the hardest metals with Cutting & Tapping Fluid

- Spray clings to the surface of the tool to prolong tool life
- Ideal for stainless steel, high nickel alloys, titanium and more
- Use for reaming, seat cutting and CBN cutting
- Aerosol • Order No. **CTF-14** Jobber \$12.49



Valve Seat Cutting Fluid

- High silicone content reduces drag on cutters so they last longer
- Promotes smoother cuts
- May be diluted up to 9:1
- Non-aerosol spray

Size	Jobber	Order No.
1 pint spray (473 mL)	\$13.79	SCF-2
1 gallon (3.79 L)	26.99	SCF-10

Remove material and recontour bowls with the GOODSON 3-D Fast Cut™ Bowl Profiler



Blade Fits Here

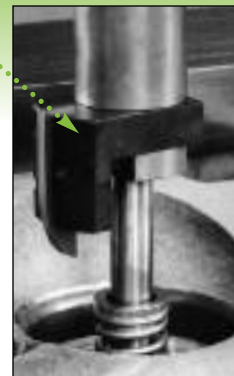

- Machine seats & bowls on a pair of V8 heads in about 40 minutes
- Remove material to recontour cylinder head bowl areas and unshroud valves in combustion chambers
- Blades can be modified using our **MGA-600** sharpener (see page 9)

Holder Diameter Range	Jobber	Order No.
1.25"-1.87" / 32-48mm	\$169.99	NBN-1
1.57"-2.13" / 40-54mm	169.99	NBN-2

Blades sold separately

Blade	Jobber	Order No.
	\$56.99	NBN-5
	\$59.99	NBN-6
	\$69.99	NBN-10
	\$95.99	NBN-12
	\$95.99	NBN-14
	\$95.99	NBN-15



Convert your Sunnen® or mira® brazed cutters to 3-D with this simple holder

This blade holder allows you to mount premium, replaceable carbide cutters on your existing mira® and Sunnen® ball-type tool holders. Choose from our wide selection of replaceable cutters, previously only available for 3-D Fast Cut™ or similar seat cutting systems.

Application	Jobber	Order No.
mira®	\$184.99	MGA-3DH
Sunnen® VSC-Series	184.99	SUN-3DH
Replacement Screw	4.99	FT-SCREW



Buy 6 or more cans SBF-16 and save 10% jobber



Check valve to seat contact easily with any of these layout methods



Description	Color	Jobber	Order No.
Layout Fluid Markers	Blue	\$11.49	VBF-2
2 oz. / 59 mL	Red	11.49	VRF-2
Layout Fluid 4oz. / 118mL	Blue	11.49	VBF-4
(includes brush)	Red	11.49	VRF-4
Spray Bluing Fluid (Aerosol)	Blue	10.79	SBF-16
Prussian Blue Machining Paste 3/4 oz. / 22mL		6.99	PB-75

Valve Seat Work



MGA-SER-1



Universal Cutter Bit Sharpener

• Kit includes 600-grit wheel, wetting agent, cleaning stick and hex key • 110V, 60 cycles

Description	Jobber	Order No.	Incl.
Sharpener Kit	\$1,049.99	MGA-600	▼
3D Cutter Holder	37.29	MGA-SER-1	
Replacement Wheels	260 Grit (roughing)	199.99	MGL-130
	600 Grit (finish)	199.99	MGL-131
Dressing Stick	8.99	LP-DS	x
Wetting Agent	23.99	MGA-659	x

Sharpen multi-angle cutters in-house on your boring bar

- Restore proper rake angles fast
- Tool holder fits on boring bar pin
- Adjusts plus or minus 6°



Arbor	Fits	Jobber	Order No.
3/8"	9.53mm Kwik-Way	\$169.99	MGA-1-KW
7/16"	11.10mm WVN, K.I.	169.99	MGA-1-VN
	Tip Holder for Sharpening Fixture	49.99	MGA-SER



Machine valve seats to a mirror-like finish with Valve Seat Machining Aid

- Universal - works with any type of cylinder head machining center
- Use full strength
- Safe for metal surfaces
- Quart (946mL)
- Order No. PF-2020
- Jobber \$24.99

Minnesota Fast Freeze instantly chills seats and guides to -50°F / -45.5°C

- Creates interference fit with heated aluminum heads • Finish seat and guide work faster than ever • Aerosol
- Use on tight bushings, pins, shafts, etc.
- Order No. MFF-8 Jobber \$19.99



Buy 6 or more cans MFF-8 and save 10% off jobber



Valve Seat Run-Out Gauge



- Hardened guide bushings & contact pilot • Quick thumb screw set-up
- Jeweled bearing indicator reads to ±.050" with .001" precision
- Range: 1.00"-2.50"

Pilot Size	Jobber	Order No.
.375"	\$149.99	VSG-375
.385"	149.99	VSG-385

Bousfield Valve Tool Replacement Cutters

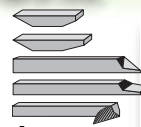

- Use with your Bousfield Valve Tool Kit • Limited quantities available

Description	Order No.
Short	WB-1
Medium	WB-2
Long	WB-3
Porting	WB-4
Carbide	WB-5

Jobber \$29.99 ea.

Valve and Seat Scribe finds valve face to seat contact

- Kit includes: tool body, scribe, 1 pilot sleeve, and 6.6mm, 8.0mm, 5/16", 11/32" and 3/8" valve stem sleeves • Sleeves fit tool body to valve stems & pilots • Use valve to set point then scribe seat with inner & outer radii • Grind seat top & throat to match face precisely

Pilot Size	Jobber	Order No.
.385" / 9.78mm Sioux™	\$49.99	ST-30-SX
.375" / 9.53mm B&D	49.99	ST-30-BD



Custom Cutter Blades are easy as 1-2-3

- 1 – Download the GOODSON Custom Formtool Profile Form from our website. Scan the code at right or go to: www.goodson.com/contact/Formtool.pdf. Don't have internet access? Call 1-800-533-8010 and ask us to fax you a copy.
- 2 – Fill out the form including a drawing of the cutter you need. Be sure to include all angles, radii, seat widths, etc. Missing information may delay your cutter or result in an incorrect profile.
- 3 – Fax the completed form to GOODSON at 507-452-2907 (or 1-888-466-3909) or e-mail it to orderdesk@goodson.com. We will have a blueprint drawn from your information, which you will need to approve before production begins.



GOODSON
Tools and Supplies for Engine Builders
156 Garwood Circle • P.O. Box 414 • Minneapolis, MN 55407
Phone: 612-452-2907 • Local: 612-452-1000 • www.goodson.com

Goodson Custom Formtool Profile Form

Customer No. _____
Name _____
Address _____
City _____ State _____ Zip _____
Phone _____ Fax _____

Top Width _____
Seat Width _____
Throat Angle _____
Main Angle _____
Top Angle _____
Tip Angle _____

□ Normal style □ Small style

Please identify your custom form tool on the graph at the right.

Custom cutters start at \$98

made-to-order crankwheels ship

CYLINDER HEAD REBUILDING

CLEANING, ASSEMBLY & SAFETY

SHORT BLOCK REBUILDING

CRANKSHAFT/FLYWHEEL GRINDING

BRAKE & ALIGNMENT TOOLS

MEASURING TOOLS

OFFROAD BIKE, ATV HARD PARTS

V-TWIN HARD PARTS

Neway Valve Seat Cutting System

CYLINDER HEAD
REBUILDING

CLEANING,
ASSEMBLY & SAFETY

SHORT BLOCK
REBUILDING

CRANKSHAFT/
FLYWHEEL GRINDING

BRAKE & ALIGNMENT
TOOLS

MEASURING
TOOLS

OFFROAD BIKE, ATV
HARD PARTS

V-TWIN
HARD PARTS



L-R: NCB-253, NCB-250,
NCB-251, NCB-252,
NCB-254

L-R:
NCB-152,
NCB-154

L-R: NCB-250LC,
NCB-251LC



L-R: NCB-260,
NCB-265, NCB-266

L-R: NCB-355,
NCB-352,
NCB-354

Accurate

The Tungsten Carbide blades on these cutters never change shape like abrasives will. You get a perfectly flat, machined surface that will give you an optimal seal and heat transfer.

Ready to use

Cutter bodies come complete with blades. Most bodies feature replaceable blades (see chart for part numbers and quantities).

Easy

The Neway Valve Seat Cutting System is very user-friendly. You can turn the cutters by hand with a T-handle or use the EZ-Turn Wrench (NTW-EZ) for a continuous turning motion. The EZ-Turn Wrench also includes a 1/2" to 3/8" adaptor NTW-503-1 to drive all cutter bodies (adaptor also sold separately).



Replaceable, Adjustable Cutter Blades

All but a few cutter bodies have replaceable tungsten carbide cutter blades.

How to Order

Cutters work in a range from 3/8" smaller and 1/4" larger than the listed cutter body size. Select cutter approximately the same size as your valve head diameter.

Description	Jobber	Order No.
Small Series Cutter Bodies (Use .297" Top Pilots - page 3)		
Cutter Body	Blade	Qty. Replacement Blade
Diameter	Angle	
0.830" / 21.1mm	32°	3 non-replaceable
0.850" / 21.6mm	45°	3 non-replaceable
0.874" / 22.2mm	60°	3 non-replaceable
0.925" / 23.5mm	45°	3 non-replaceable
0.975" / 24.8mm	31°	3 NCB-250
	31°	3 NCB-253
	45°	3 NCB-253
1.000" / 25.4mm	15°	3 NCB-253
	30°	3 NCB-250
	60°	3 NCB-252
	75°	3 NCB-254
1.125" / 28.6mm	31°/46°	3/3 NCB-253
1.312" / 33.3mm	31°/46°	3/3 NCB-251
	15°/60°	3/3 NCB-251, -254
Replacement Blades	Angle	Blade Lgth.
	15-46°	5/16" / 7.9mm
		3/8" / 9.53mm
		1/2" / 12.7mm
	60-75°	1/2" / 12.7mm
		3/4" / 19.05mm
Non-Serrated Correction Blades	60-75°	1/2" / 12.7mm
		3/4" / 19.05mm
Hard Seat Blades	15-46°	3/8" / 9.53mm
		1/2" / 12.7mm
Radius Combustion Chamber Blades		3/8" / 9.53mm
		1/2" / 12.7mm
		3/4" / 19.05mm
Flat Head Screw		\$ 2.29 NCB-260
Wedge for bodies over 1" / 25.4mm		2.29 NCB-265
Wedge for 1" / 25.4mm & smaller bodies		2.29 NCB-266
Storage Cases	Small (holds 3 pieces)	14.79 NCA-303
	Medium (holds 6 pieces)	19.79 NCA-160
	Large (holds 11 pieces)	29.29 NCA-497
EZ-Turn Wrench		69.99 NTW-EZ
1/2" T-Handle Driver		12.49 NTW-505
3/8" T-Handle Driver		12.49 NTW-513
Drive Adaptor	1/2" to 3/8" / 12.7-9.53mm	11.49 NTW-503-1

Description	Jobber	Order No.
Standard Series Cutter Bodies (Use .375" Top Pilots - page 3)		
Cutter Body	Blade	Qty. Replacement Blade
Diameter	Angle	
1.125" / 28.6mm	30°	3 NCB-250
	45°	3 NCB-250
	60°	3 NCB-252
	75°	3 NCB-254
1.250" / 31.6mm	15°	3 NCB-250
	30°	3 NCB-250
	30°/45°	6 NCB-250
	31°/46°	3/3 NCB-250
	45°	3 NCB-250
	60°	3 NCB-252
1.375" / 35.0mm	15°/60°	5/5 NCB-251, -254
	30°/45°	3/3 NCB-250, -251
1.500" / 38.0mm	15°/75°	3/3 NCB-251, -254
	30°/45°	3/3 NCB-251
	30°/45°	5/5 NCB-251
	31°/46°	10 NCB-251
	60°	3 NCB-254
	70°	3 NCB-254
1.750" / 44.5mm	15°/60°	5/5 NCB-251, -254
	31°/46°	10 NCB-251
	55°	5 NCB-251
	60°	3 NCB-254
	75°	3 NCB-254
2.000" / 50.8mm	31°/46°	10 NCB-251
	15°/60°	5/5 NCB-251, -254
	30°/45°	5/5 NCB-251
	50°	5 NCB-251
2.25" / 57.0mm	50°	5 NCB-251
	55°	5 NCB-251
	30°/45°	7/7 NCB-251
	15°/60°	5/5 NCB-251, -254
2.50" / 63.5mm	30°/45°	7/7 NCB-251
	50°	7 NCB-251
	55°	7 NCB-251

Other cutters are available by special order
Shaded Rows represent NEW items for 2012



KA-462 - Neway Jobber Kit



GKM-2450 - Neway Harley-Davidson Kit

More Neway Valve Seat Cutting Products are Available

The Neway Valve Seat Cutting System is made up of many cutter bodies, pilots, accessories and more. More than we can fit in our catalog that is. Goodson has arranged with Neway to offer anything that is in their product line to our customers. If the item you're looking for isn't shown in the chart on the previous page, you can still get it from Goodson by special order.

A comprehensive list of cutter bodies, kits and accessories are shown on our website. You can order them through the site, or call one of our customer service representatives at 1-800-533-8010.

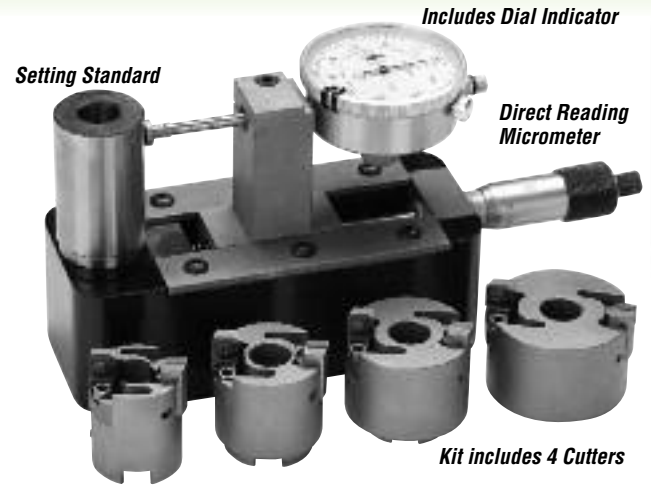

Includes Dial Indicator

Setting Standard

Direct Reading Micrometer

Kit includes 4 Cutters

Customize Counterbore Cutters with the GOODSON Adjustable Counterbore Cutter Kit

- Cutter assemblies feature positive stop adjusting screws to prevent cutters from changing dimensions when in use
- Direct reading micrometer and dial indicator for fast, accurate set-up
- 8 cutter assemblies to choose from, covering a range from 1.25" to 3.00" diameter
- Kit substitutions, call to inquire
- Heavy duty billet steel construction

Complete Kit	Jobber	Order No.	Incl.
3/16" / 14.3mm Arbor	\$1,899.99	DWA-300	▼
Cutter Assemblies (in/mm)			
3/16" Arbor 1.250"-1.375"/31.8-34.9	\$346.99	DWA-250	x
1.375"-1.500"/34.9-38.1	399.99	DWA-375	x
1.500"-1.750"/38.1-44.5	399.99	DWA-302	x
1.750"-2.000"/44.5-50.8	399.99	DWA-303	x
2.000"-2.250"/50.8-57.2	399.99	DWA-304	
2.250"-2.500"/57.2-63.5	399.99	DWA-305	
2.500"-2.750"/63.5-69.9	399.99	DWA-306	
2.750"-3.000"/69.9-76.2	399.99	DWA-307	
Cutting Insert	29.99	DKB-7	x
Set Screw	11.99	DKS-7	x
Wrench	11.79	DKW-7	x

Choose your Wear Sleeves for Counter Bore Cutters

Wear Sleeves
For 3/16" (14.27mm) arbor DCW & DWI style seat cutters

Pilot Top Size	Order No.
.375" (9.53mm)	DCW-375
.385" (9.78mm)	DCW-385
.437" (11.10mm)	DCW-437

Jobber \$69.99

Wear Sleeves
For 5/16" (15.87mm) arbor KWP & KPI style seat cutters

Pilot Top Size	Order No.
.375" (9.53mm)	KWP-375
.385" (9.78mm)	KWP-385
.437" (11.10mm)	KWP-437

Jobber \$69.29

Cutter Drivers & Adaptors

CD-MT3 shown with DCW series wear sleeve adapting 5/8" to 9/16"



Cutters Drivers	Jobber	Order No.
#3 MT Driver	\$279.99	CD-MT3
1/2" / 12.7 mm Driver (fits Jacobs chuck)	259.99	KW-022
Fits .750" Bridgeport Collet		
3/16" arbor, .375" pilot	129.79	DCW-60-375
3/16" arbor, .385" pilot	129.79	DCW-60-385
5/8" arbor, .375" pilot	109.29	KWP-60-375
5/8" arbor, .385" pilot	109.29	KWP-60-385
Drive Adaptor for Serdi Machines	289.99	DVR-SER

Bridgeport 3/4"

Serdi



DCW-60-375

Available in 9/16" or 5/8"



DVR-SER

Available in 9/16" only

To use the Counterbore Cutter Kit with Kwik-Way & Peterson Machines you will need to adapt the 9/16" cutter to fit the 5/8" drive. Use a DCW wear sleeve or from the charts at left.

CYLINDER HEAD REBUILDING

CLEANING, ASSEMBLY & SAFETY

SHORT BLOCK REBUILDING

CRANKSHAFT/ FLYWHEEL GRINDING

BRAKE & ALIGNMENT TOOLS

MEASURING TOOLS

OFFROAD BIKE, ATV HARD PARTS

V-TWIN HARD PARTS

From our customers:

"We have been doing business with Goodson for over 10 years. They have outstanding customer service and a great selection of specialty tooling and parts for Harleys."
 - Bob LaGuardia, Diamond Bar Choppers, Diamond Bar CA, Goodson customer since 2000



DWI-SERIES

- Fits DCM Tech, Sunnen, and Winona Van Norman
- 9/16" / 14.3mm arbor

KPI-SERIES

- Fits Kansas Instruments, Kwik-Way and Peterson
- 5/8" / 15.9mm arbor

Save money with seat cutters you can service in your shop – Indexable Counterbore Cutters

These indexable counterbore cutters eliminate down time from having brazed cutters reset or sharpened. You can service them right in your own shop! Each cutter body includes 2 carbide cutter tips with 4 cutting edges. When one edge wears, simply rotate the tip to a new cutting edge. You'll also get insert screws and a wrench with every cutter body.

Exclusive

Replacement Inserts for 5/8" Arbor IDL-Series Carbide Seat Cutters

These seat cutters aren't made any longer, but we have the replacement inserts to keep you going!



Range	IDL#	Lgth.	Order No.
1.25"-1.342"	8102	5/16"	ID-802
1.375"-2.28"	8103	3/8"	ID-803
1.562"-2.28"	8104	1/2"	ID-804

Jobber \$17.99

Nickel-Chrome Valve Seats For a Variety Of Applications

more seats on page 129

OD	ID	Depth	Order No.	OD	ID	Depth	Order No.
1.250"	0.812"	1/4"	VS-1250	1.625"	1.375"	7/32"	VS-1625A
1.312"	1.000"	1/4"	VS-1312	1.687"	1.375"	1/4"	VS-1687
1.375"	1.062"	1/4"	VS-1375	1.750"	1.500"	1/4"	VS-1750
1.437"	1.125"	1/4"	VS-1437	1.812"	1.500"	1/4"	VS-1812
1.500"	1.187"	1/4"	VS-1500	1.875"	1.562"	1/4"	VS-1875
1.562"	1.250"	1/4"	VS-1562	1.937"	1.625"	1/4"	VS-1937
1.562"	1.312"	7/32"	VS-1562A	2.000"	1.625"	1/4"	VS-2000
1.625"	1.312"	1/4"	VS-1625				Jobber \$6.99

Buy 12 or more, save 10% off jobber

Valve Seat Removers – A Low-Cost Way to Pull Valve Seat Inserts

- Use to pry out valve seat inserts or stubborn grease seals • Three angles available
- **Not** recommended for use on aluminum heads
- Set includes one of each angle

Description	Jobber	Order No.
3-Pc. Set	\$129.99	VSP-SET
90°	54.99	VSP-90
100°	54.99	VSP-100
120°	54.99	VSP-120

DWI-Series DCM Tech, WVN (9/16" arbor)				KPI-Series K.I., KW, Peterson (5/8" arbor)	
Size	mm	Jobber	Order No.	Jobber	Order No.
1.000"	25.40	\$199.99	DWI-1000	—	—
1.062"	26.99	199.99	DWI-1062	—	—
1.125"	28.58	199.99	DWI-1125	—	—
1.187"	30.15	199.99	DWI-1187	—	—
1.250"	31.75	179.99	DWI-1250	\$179.99	KPI-1250
1.312"	33.32	179.99	DWI-1312	179.99	KPI-1312
1.375"	34.93	179.99	DWI-1375	179.99	KPI-1375
1.437"	36.50	179.99	DWI-1437	179.99	KPI-1437
1/4" Replacement Cutting Insert for Cutters above				22.99	SCI-250-B
Replacement Screw for SCI-250-B				4.59	SCS-T8
Allen Wrench for SCS-T7				6.79	SCW-T7
Size	mm	Jobber	Order No.	Jobber	Order No.
1.500"	38.10	\$179.99	DWI-1500	\$179.99	KPI-1500
1.562"	39.67	179.99	DWI-1562	179.99	KPI-1562
1.625"	41.28	179.99	DWI-1625	179.99	KPI-1625
1.687"	42.85	179.99	DWI-1687	179.99	KPI-1687
1.750"	42.85	179.99	DWI-1750	179.99	KPI-1750
1.812"	44.45	179.99	DWI-1812	179.99	KPI-1812
1.875"	47.63	179.99	DWI-1875	179.99	KPI-1875
1.937"	49.20	179.99	DWI-1937	179.99	KPI-1937
2.000"	50.80	179.99	DWI-2000	179.99	KPI-2000
2.062"	52.37	179.99	DWI-2062	179.99	KPI-2062
2.125"	53.98	179.99	DWI-2125	179.99	KPI-2125
2.187"	55.55	179.99	DWI-2187	179.99	KPI-2187
2.250"	57.15	179.99	DWI-2250	179.99	KPI-2250
3/8" Replacement Cutting Insert for Cutters above				37.99	SCI-375-B
Replacement Screw for SCI-375-B				2.29	SCS-T15
Torx Wrench for SCW-T15				5.49	SCW-T15



Manual



3/4"

Pneumatic

3/4"

Valve Seat Drivers For Fast Seat Installation

- Pneumatic Drivers install seats faster, easier and without galling • Driver Head ID is .75" / 19.05mm

Use with Press Fit Lube (PFL-200) p. 26



Description	Jobber	Order No.
Manual Drivers		
.437" / 11.10mm ID	\$41.29	VSD-201-G
.375" / 9.53mm and .385" / 9.78mm ID	41.29	VSD-202-G
Driver Heads		
1" thru 1 1/8" Seats / 25.4 - 28.6mm	\$39.99	VSD-203-G
1 1/4" thru 1 3/8" Seats / 31.8 - 34.9mm	39.99	VSD-204-G
1 1/2" thru 1 7/8" Seats / 38.1 - 41.3mm	39.99	VSD-205-G
1 3/4" thru 1 7/8" Seats / 44.5 - 47.6mm	39.99	VSD-206-G
2" thru 2 1/8" Seats / 50.8 - 54.0mm	39.99	VSD-207-G
1 3/4" thru 2" Seats / 44.5 - 50.8mm	29.99	VSD-HD
Pneumatic Drivers		
.375" / 9.53mm and .385" / 9.78mm ID	\$36.29	PSD-385
.437" / 11.10mm ID	34.99	PSD-437

CYLINDER HEAD REBUILDING

CLEANING, ASSEMBLY & SAFETY

SHORT BLOCK REBUILDING

CRANKSHAFT/ FLYWHEEL GRINDING

BRAKE & ALIGNMENT TOOLS

MEASURING TOOLS

OFFROAD BIKE, ATV HARD PARTS

V-TWIN HARD PARTS

Valve Lapping Tools & Supplies

CYLINDER HEAD REBUILDING

CLEANING, ASSEMBLY & SAFETY

SHORT BLOCK BUILDING

CRANKSHAFT/FLYWHEEL GRINDING

BRAKE & ALIGNMENT TOOLS

MEASURING TOOLS

OFFROAD BIKE, ATV HARD PARTS

V-TWIN HARD PARTS

Lapping Compound

- Silicone-carbide, grease-based compound
- Precise mating between valves and seats for fast cutting



Grit	Size	Jobber	Order No.
400	2 oz. / 56.7g	\$11.99	VLC-2-400
600	2 oz. / 56.7g	11.99	VLC-2-600
800	2 oz. / 56.7g	11.99	VLC-2-800
1000	2 oz. / 56.7g	11.99	VLC-2-1000
120, 280	2 oz. / 56.7g ea.	19.99	VLC-4
120	1 lb. / 453.6g	56.99	VLC-120
180	1 lb. / 453.6g	56.99	VLC-180
280	1 lb. / 453.6g	49.99	VLC-280



Vacuum Style Lapping Stick

- Press the spring-loaded vacuum pump for a firm hold – stays on until you release the vacuum
- Includes 3 cup sizes (also sold separately)

Description	Jobber	Order No.
Vacuum Lapping Stick	\$32.99	VLV-50
Replacement Cups		
19.1mm / 0.750" dia.	7.99	VLV-3/4
25.4mm / 1.000" dia.	7.99	VLV-1
31.8mm / 1.250" dia.	7.99	VLV-1 1/4



Traditional Valve Lapping Sticks

- Oil resistant polyethylene handles
- Locking tabs eliminate cup slippage

Description	Jobber	Order No.
Small Lapping Stick	\$7.99	VLS-15
Replacement Cups		
15.9mm / 0.625" dia.	5.99	VLS-5/8
20.6mm / 0.813" dia.	5.99	VLS-13/16
Large Lapping Stick	7.99	VLS-30
Replacement Cups		
28.6mm / 1.125" dia.	5.99	VLS-1 1/8
34.9mm / 1.375" dia.	5.99	VLS-1 3/8



“The Plunger” Hand Valve Lapping Stick

- Large diameter for sure grip
- For 2" and larger valves

Description	Jobber	Order No.
Hand Valve Lapping Stick	\$6.99	VLS-75
Replacement Cup	44.5mm / 1.750" dia.	3.99 VLS-1 3/4

Air Powered Valve Lapping Tool

- Operates on 90psi
- Includes air tool and 3 replacement cups • Air actuated ... no electricity needed • Cups also sold separately



Description	Jobber	Order No.
Air Powered Valve Lapping Tool	\$399.99	AVLP-300
Replacement Cups		
21mm / 0.827" dia.	8.99	AVLP-301
33mm / 1.299" dia.	8.99	AVLP-302
38mm / 1.496" dia.	8.99	AVLP-303

Mechanical Valve Lapping Tool

- Auto oscillation with a simple crank
- Includes blade drive for slotted valves

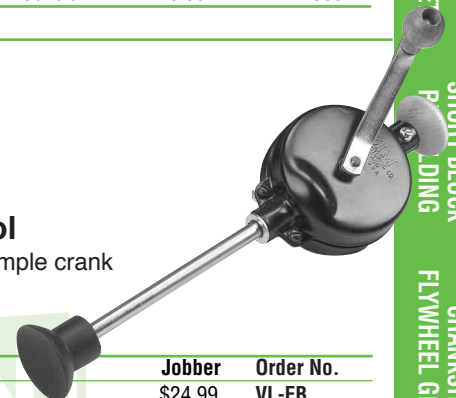

Description	Jobber	Order No.
Mechanical Valve Lapping Tool	\$24.99	VL-EB
Replacement Cups		
33.3mm / 1.313" dia.	3.99	VLS-1 5/16
44.5mm / 1.750" dia.	3.99	VLS-1 3/4

Powered Lapping Tool

- Change rotary action into an effective oscillating motion • Drive with a power drill
- Makes lapping faster and easier • Includes 2 cup sizes



Description	Jobber	Order No.
Complete Tool	\$164.99	VLP-100
Replacement Cups		
22.2mm / 0.875" dia.	9.99	VLP-10
25.4mm / 1.000" dia.	9.99	VLP-20



Buy 6 or more cans SBF-16 and save 10%



Check valve to seat contact

Description	Color	Jobber	Order No.
Layout Fluid Markers	Blue	\$11.49	VBF-2
2 oz. / 59 mL	Red	11.49	VRF-2
Layout Fluid 4oz. / 118mL (includes brush)	Blue	11.49	VBF-4
	Red	13.49	VRF-4
Spray Bluing Fluid (Aerosol)	Blue	10.79	SBF-16
Prussian Blue Machining Paste ¼ oz. / 22mL		6.99	PB-75

same-day shipping



Save 10% on 10!

Order 10 or more Valve Seat Wheels
(any combination, pages 14-16)
and we'll give you 10% off jobber

SX

Fits Sioux™, KO Lee, US, Thor, Skil, Winona 11/16x16 thread

Colors may vary due to manufacturing processes

Size			General Purpose (GP)				Cool Blue (CB)		Ruby	
Inch	mm	Jobber	00°	30°	45°	60°	00°	45°	00°	45°
7/8"	22	\$21.19	---	---	---	---	---	---	SX-500-R	SX-545-R
15/16"	24	21.19	---	---	---	---	---	---	SX-600-R	SX-645-R
1"	25	21.19	---	---	---	---	---	---	SX-700-R	SX-745-R
1 1/16"	27	21.19	---	---	---	---	---	---	SX-800-R	SX-845-R
1 1/8"	28	21.19	SX-900-GP	SX-930-GP	SX-945-GP	---	---	---	SX-900-R	SX-945-R
1 1/4"	30	21.19	SX-900A-GP	---	SX-945A-GP	---	---	---	---	---

Size			Stellite (S)			Finishing (F)			Nickel Chrome		
Inch	mm	Jobber	00°	30°	45°	00°	30°	45°	00°	30°	45°
1/2"	12.7	\$21.19	---	---	---	---	---	---	SX-200-NC	---	---
9/16"	14.3	21.19	---	---	---	---	---	---	SX-200A-NC	---	---
5/8"	15.9	21.19	---	---	---	---	---	---	SX-300-NC	---	---
11/16"	17.4	21.19	---	---	---	---	---	---	SX-300A-NC	---	---
3/4"	19.1	21.19	---	---	---	---	---	---	SX-400-NC	---	---
13/16"	20.6	21.19	---	---	---	---	---	---	SX-400A-NC	---	---
7/8"	22	21.19	---	---	---	SX-500-F	---	SX-545-F	SX-500-NC	---	SX-545-NC
15/16"	24	21.19	---	---	---	SX-600-F	---	SX-645-F	SX-600-NC	---	SX-645-NC
1"	25	21.19	---	---	---	SX-700-F	---	SX-745-F	SX-700-NC	---	SX-745-NC
1 1/16"	27	21.19	---	---	---	SX-800-F	---	SX-845-F	SX-800-NC	---	SX-845-NC
1 1/8"	28	21.19	SX-900-S	SX-930-S	SX-945-S	SX-900-F	SX-930-F	SX-945-F	SX-900-NC	SX-930-NC	SX-945-NC
1 1/4"	30	21.19	SX-900A-S	---	SX-945A-S	SX-900A-F	---	SX-945A-F	SX-900A-NC	---	SX-945A-NC

Size			General Purpose (GP)				Cool Blue (CB)		Ruby	
Inch	mm	Jobber	00°	30°	45°	60°	00°	45°	00°	45°
1 1/4"	32	\$13.49	SX-1000-GP	SX-1030-GP	SX-1045-GP	SX-1060-GP	SX-1000-CB	SX-1045-CB	SX-1000-R	SX-1045-R
1 1/8"	33	13.49	SX-1000A-GP	---	SX-1045A-GP	---	SX-1000A-CB	SX-1045A-CB	---	---
1 3/8"	35	13.49	SX-1100-GP	SX-1130-GP	SX-1145-GP	SX-1160-GP	SX-1100-CB	SX-1145-CB	SX-1100-R	SX-1145-R
1 1/2"	36	13.49	SX-1100A-GP	---	SX-1145A-GP	---	SX-1100A-CB	SX-1145A-CB	---	---
1 1/2"	38	13.49	SX-1200-GP	SX-1230-GP	SX-1245-GP	SX-1260-GP	SX-1200-CB	SX-1245-CB	SX-1200-R	SX-1245-R
1 5/8"	39	13.49	SX-1200A-GP	---	SX-1245A-GP	---	SX-1200A-CB	SX-1245A-CB	---	---
1 5/8"	41	13.49	SX-1300-GP	SX-1330-GP	SX-1345-GP	SX-1360-GP	SX-1300-CB	SX-1345-CB	SX-1300-R	SX-1345-R
1 11/16"	43	13.49	SX-1300A-GP	---	SX-1345A-GP	---	SX-1300A-CB	SX-1345A-CB	---	---
1 3/4"	44	13.49	SX-1400-GP	SX-1430-GP	SX-1445-GP	SX-1460-GP	SX-1400-CB	SX-1445-CB	SX-1400-R	SX-1445-R
1 7/8"	47	13.49	SX-1500-GP	SX-1530-GP	SX-1545-GP	SX-1560-GP	SX-1500-CB	SX-1545-CB	SX-1500-R	SX-1545-R
2"	51	13.49	SX-1600-GP	SX-1630-GP	SX-1645-GP	SX-1660-GP	SX-1600-CB	SX-1645-CB	SX-1600-R	SX-1645-R
2 1/8"	54	13.49	SX-1700-GP	SX-1730-GP	SX-1745-GP	---	SX-1700-CB	SX-1745-CB	SX-1700R	SX-1745-R
2 1/4"	57	13.49	SX-1800-GP	SX-1830-GP	SX-1845-GP	SX-1860-GP	SX-1800-CB	SX-1845-CB	SX-1800-R	SX-1845-R
2 3/8"	60	13.49	SX-1900-GP	SX-1930-GP	SX-1945-GP	SX-1960-GP	SX-1900-CB	SX-1945-CB	SX-1900-R	SX-1945-R
2 1/2"	63	13.49	SX-2000-GP	SX-2030-GP	SX-2045-GP	---	SX-2000-CB	SX-2045-CB	SX-2000-R	SX-2045-R
2 5/8"	66	13.49	SX-2100-GP	SX-2130-GP	SX-2145-GP	---	---	SX-2145-CB	---	---

Size			Stellite (S)			Finishing (F)			Nickel Chrome				
Inch	mm	Jobber	00°	30°	45°	Jobber	00°	30°	45°	Jobber	00°	30°	45°
1 1/4"	32	\$12.99	SX-1000-S	SX-1030-S	SX-1045-S	\$11.49	SX-1000-F	SX-1030-F	SX-1045-F	\$13.99	SX-1000-NC	SX-1030-NC	SX-1045-NC
1 1/8"	33	12.99	SX-1000A-S	---	SX-1045A-S	11.49	SX-1000A-F	---	SX-1045A-F	13.99	SX-1000A-NC	---	SX-1045A-NC
1 3/8"	35	12.99	SX-1100-S	SX-1130-S	SX-1145-S	11.49	SX-1100-F	SX-1130-F	SX-1145-F	13.99	SX-1100-NC	SX-1130-NC	SX-1145-NC
1 1/2"	36	12.99	SX-1100A-S	---	SX-1145A-S	11.49	SX-1100A-F	---	SX-1145A-F	13.99	SX-1100A-NC	---	SX-1145A-NC
1 1/2"	38	12.99	SX-1200-S	SX-1230-S	SX-1245-S	11.49	SX-1200-F	SX-1230-F	SX-1245-F	13.99	SX-1200-NC	SX-1230-NC	SX-1245-NC
1 5/8"	39	12.99	SX-1200A-S	---	SX-1245A-S	11.49	SX-1200A-F	---	SX-1245A-F	13.99	SX-1200A-NC	---	SX-1245A-NC
1 5/8"	41	12.99	SX-1300-S	SX-1330-S	SX-1345-S	11.49	SX-1300-F	SX-1330-F	SX-1345-F	13.99	SX-1300-NC	SX-1330-NC	SX-1345-NC
1 11/16"	43	12.99	SX-1300A-S	---	SX-1345A-S	11.49	SX-1300A-F	---	SX-1345A-F	13.99	SX-1300A-NC	---	SX-1345A-NC
1 3/4"	44	12.99	SX-1400-S	SX-1430-S	SX-1445-S	11.49	SX-1400-F	SX-1430-F	SX-1445-F	13.99	SX-1400-NC	SX-1430-NC	SX-1445-NC
1 7/8"	47	12.99	SX-1500-S	SX-1530-S	SX-1545-S	11.49	SX-1500-F	SX-1530-F	SX-1545-F	13.99	SX-1500-NC	SX-1530-NC	SX-1545-NC
2"	51	12.99	SX-1600-S	SX-1630-S	SX-1645-S	11.49	SX-1600-F	SX-1630-F	SX-1645-F	13.99	SX-1600-NC	SX-1630-NC	SX-1645-NC
2 1/8"	54	12.99	SX-1700-S	SX-1730-S	SX-1745-S	11.49	SX-1700-F	SX-1730-F	SX-1745-F	13.99	SX-1700-NC	SX-1730-NC	SX-1745-NC
2 1/4"	57	12.99	SX-1800-S	SX-1830-S	SX-1845-S	11.49	SX-1800-F	SX-1830-F	SX-1845-F	13.99	SX-1800-NC	SX-1830-NC	SX-1845-NC
2 3/8"	60	12.99	SX-1900-S	SX-1930-S	SX-1945-S	13.99	SX-1900-F	SX-1930-F	SX-1945-F	13.99	SX-1900-NC	SX-1930-NC	SX-1945-NC
2 1/2"	63	12.99	SX-2000-S	SX-2030-S	SX-2045-S	13.99	SX-2000-F	SX-2030-F	SX-2045-F	13.99	SX-2000-NC	SX-2030-NC	SX-2045-NC

All Valve Seat Wheels are guaranteed against manufacturing defects for 1 year from original purchase date

order at 1-800-533-8010 (outside the US & Canada, 1-507-452-1830) or online at www.goodson.com



All Goodson seat wheels are built to last and grind seats accurately

- Brass bushings resist galling or seizing to the holder
- Heat-cured, permanent epoxy bonding prevents loose bushings
- Bushings are set deep to expose the most abrasive for long life
- Each wheel is pre-trued and checked to assure accurate, vibration-free grinding

Custom angles and sizes are available in house. Call for more information.

KW

Fits Kwik-Way 13/16x13 thread

Size	General Purpose (GP)						Cool Blue (CB)		Finishing (F)		Stellite (S)	
	Inch	mm	Jobber	00°	30°	45°	00°	45°	45°	00°	45°	
1 1/4"	32	\$13.99	KW-1000-GP	KW-1030-GP	KW-1045-GP	KW-1000-CB	KW-1045-CB	KW-1045-F	KW-1000-S	KW-1045-S		
1 1/8"	33	13.99	KW-1000A-GP	—	KW-1045A-GP	KW-1000A-CB	KW-1045A-CB	—	—	—		
1 3/8"	35	13.99	KW-1100-GP	KW-1130-GP	KW-1145-GP	KW-1100-CB	KW-1145-CB	KW-1145-F	KW-1100-S	KW-1145-S		
1 1/2"	36	13.99	KW-1100A-GP	—	KW-1145A-GP	KW-1100A-CB	KW-1145A-CB	KW-1145A-F	KW-1100A-S	KW-1145A-S		
1 5/8"	38	13.99	KW-1200-GP	KW-1230-GP	KW-1245-GP	KW-1200-CB	KW-1245-CB	KW-1245-F	KW-1200-S	KW-1245-S		
1 3/4"	39	13.99	KW-1200A-GP	—	KW-1245A-GP	—	KW-1245A-CB	KW-1245A-F	KW-1200A-S	KW-1245A-S		
1 7/8"	41	13.99	KW-1300-GP	KW-1330-GP	KW-1345-GP	KW-1300-CB	KW-1345-CB	KW-1345-F	KW-1300-S	KW-1345-S		
1 15/16"	43	13.99	KW-1300A-GP	—	KW-1345A-GP	KW-1300A-CB	KW-1345A-CB	KW-1345A-F	KW-1300A-S	KW-1345A-S		
1 3/4"	44	13.99	KW-1400-GP	KW-1430-GP	KW-1445-GP	KW-1400-CB	KW-1445-CB	KW-1445-F	KW-1400-S	KW-1445-S		
1 7/8"	47	13.99	KW-1500-GP	KW-1530-GP	KW-1545-GP	KW-1500-CB	KW-1545-CB	KW-1545-F	KW-1500-S	KW-1545-S		
2"	51	13.99	KW-1600-GP	KW-1630-GP	KW-1645-GP	KW-1600-CB	KW-1645-CB	KW-1645-F	KW-1600-S	KW-1645-S		
2 1/8"	54	13.99	KW-1700-GP	KW-1730-GP	KW-1745-GP	KW-1700-CB	KW-1745-CB	KW-1745-F	KW-1700-S	KW-1745-S		
2 1/4"	57	13.99	KW-1800-GP	KW-1830-GP	KW-1845-GP	KW-1800-CB	KW-1845-CB	KW-1845-F	KW-1800-S	KW-1845-S		
2 3/8"	60	13.99	KW-1900-GP	KW-1930-GP	KW-1945-GP	KW-1900-CB	KW-1945-CB	—	—	—		
2 1/2"	63	13.99	KW-2000-GP	KW-2030-GP	KW-2045-GP	KW-2000-CB	KW-2045-CB	—	—	—		

Size	Nickel Chrome (NC)				Ruby (R)	
	Inch	mm	Jobber	00°	45°	00°
1"	25	\$14.99	KW-700-NC	KW-745-NC	KW-700-R	KW-745-R
1 1/8"	27	14.99	KW-800-NC	KW-845-NC	KW-800-R	KW-845-R
1 1/4"	28	14.99	KW-900-NC	KW-945-NC	KW-900-R	KW-945-R
1 1/2"	32	14.99	KW-1000-NC	KW-1045-NC	KW-1000-R	KW-1045-R
1 3/8"	35	14.99	KW-1100-NC	KW-1145-NC	KW-1100-R	KW-1145-R
1 1/2"	36	14.99	KW-1100A-NC	KW-1145A-NC	—	—
1 5/8"	38	14.99	KW-1200-NC	KW-1245-NC	KW-1200-R	KW-1245-R
1 3/4"	39	14.99	KW-1200A-NC	KW-1245A-NC	—	—
1 7/8"	41	14.99	KW-1300-NC	KW-1345-NC	KW-1300-R	KW-1345-R
1 15/16"	43	14.99	KW-1300A-NC	KW-1345A-NC	—	—
1 3/4"	44	14.99	KW-1400-NC	KW-1445-NC	KW-1400-R	KW-1445-R
1 7/8"	47	14.99	KW-1500-NC	KW-1545-NC	KW-1500-R	KW-1545-R
2"	51	14.99	KW-1600-NC	KW-1645-NC	KW-1600-R	KW-1645-R

Large Diameter Valve Seat Wheels

• For Kwik-Way

Inch	mm	General Purpose			Nickel-Chrome		Cool Blue	
		Order No.	Order No.	Order No.	Order No.	Order No.	Order No.	
3"	76.2	KWL-2345-GP	KWL-2345-NC	KWL-2345-CB				
3 1/4"	82.5	KWL-2445-GP	KWL-2445-NC	KWL-2445-CB				
3 1/2"	88.9	KWL-2545-GP	KWL-2545-NC	KWL-2545-CB				
3 3/4"	92.3	KWL-2645-GP	KWL-2645-NC	KWL-2645-CB				
4"	101.6	KWL-2745-GP	KWL-2745-NC	KWL-2745-CB				
Jobber		\$26.99	\$26.99	\$26.99				



GP
General Purpose
Removes material from cast-iron seats or inserts.



S
Stellite
Specially formulated to grind Stellite and other types of hardened seat inserts, ie. Diesel & Industrial.



NC
Nickel Chrome
For aluminum heads with chrom-alloy seat inserts. Won't load up or groove.

6 ABRASIVE FORMULAS TO CHOOSE FROM



CB
Cool Blue
Superior general purpose stone for high performance Beryllium seats. Cuts faster.



F
Finishing
Gives an ideal final finish with minimal stock removal.



R
Ruby
The original Black & Decker composition, general purpose stone.

Colors may vary due to manufacturing processes

Ordering is as easy as 1-2-3!



- 1 - Find the diameter you need (valve head dia. + 1/16" to 1/8").
- 2 - Find the angle you need. You can modify the angles with our Valve Seat Stone Dresser (see page 17).
- 3 - Select the abrasive to match your job.



Save 10% on 10!

Order 10 or more Valve Seat Wheels (any combination, pages 14-16) and we'll give you 10% off jobber



no minimum orders required

CYLINDER HEAD REBUILDING
 CLEANING, ASSEMBLY & SAFETY
 SHORT BLOCK REBUILDING
 FLYWHEEL GRINDING
 CRANKSHAFT/ BRAKE & ALIGNMENT TOOLS
 MEASURING TOOLS
 OFFROAD BIKE, ATV HARD PARTS
 V-TWIN HARD PARTS

CYLINDER REBUILDING
CLEANING, ASSEMBLY & SAFETY
SHORT BLOCK REBUILDING
CRANKSHAFT/ FLYWHEEL GRINDING
BRAKE & ALIGNMENT TOOLS
MEASURING TOOLS
OFFROAD BIKE, ATV HARD PARTS
V-TWIN HARD PARTS

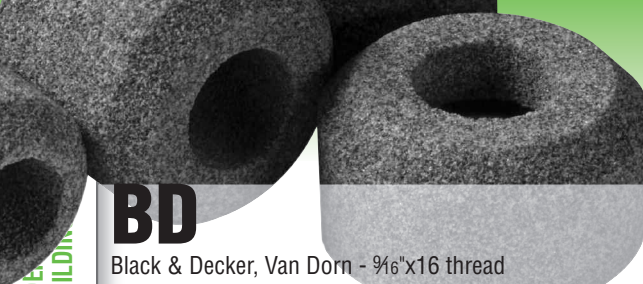

Save 10% on 10!
Order 10 or more Valve Seat Wheels (any combination, pages 14-16) and we'll give you 10% off jobber

SO
Snap-On (Blue Point) - 5/8"x18 thread

BD
Black & Decker, Van Dorn - 9/16"x16 thread

Size			General Purpose (GP)			Stellite (S)			General Purpose (GP)			Stellite (S)
Inch	mm	Jobber	00°	30°	45°	Jobber	00°	45°	Jobber	45°	00°	
1 1/4"	32	\$12.49	BD-1000-GP	BD-1030-GP	BD-1045-GP	\$12.99	BD-1000-S	BD-1045-S	\$11.99	SO-1045-GP	SO-1000-S	
1 5/16"	33	12.49	BD-1000A-GP		BD-1045A-GP	12.99	BD-1000A-S	BD-1045A-S				
1 3/8"	35	12.49	BD-1100-GP	BD-1130-GP	BD-1145-GP	12.99	BD-1100-S	BD-1145-S	11.99	SO-1145-GP	SO-1100-S	
1 7/16"	36	12.49	BD-1100A-GP		BD-1145A-GP	12.99	BD-1100A-S	BD-1145A-S				
1 1/2"	38	12.49	BD-1200-GP	BD-1230-GP	BD-1245-GP	12.99	BD-1200-S	BD-1245-S	11.99	SO-1245-GP	SO-1200-S	
1 9/16"	39	12.49	BD-1200A-GP		BD-1245A-GP	12.99	BD-1200A-S	BD-1245A-S				
1 5/8"	41	12.49	BD-1300-GP	BD-1330-GP	BD-1345-GP	12.99	BD-1300-S	BD-1345-S	11.99	SO-1345-GP	SO-1300-S	
1 11/16"	43	12.49	BD-1300A-GP		BD-1345A-GP	12.99	BD-1300A-S	BD-1345A-S				
1 3/4"	44	12.49	BD-1400-GP	BD-1430-GP	BD-1445-GP	12.99	BD-1400-S	BD-1445-S	11.99	SO-1445-GP	SO-1400-S	
1 7/8"	47	12.49	BD-1500-GP	BD-1530-GP	BD-1545-GP	12.99	BD-1500-S	BD-1545-S	11.99	SO-1545-GP	SO-1500-S	
2"	51	12.49	BD-1600-GP	BD-1630-GP	BD-1645-GP	12.99	BD-1600-S	BD-1645-S	11.99	SO-1645-GP	SO-1600-S	
2 1/8"	54	12.49	BD-1700-GP	BD-1730-GP	BD-1745-GP	12.99	BD-1700-S	BD-1745-S				
2 1/4"	57	12.49	BD-1800-GP	BD-1830-GP	BD-1845-GP	12.99	BD-1800-S	BD-1845-S				
2 3/8"	60	12.49	BD-1900-GP	BD-1930-GP	BD-1945-GP	12.99	BD-1900-S	BD-1945-S				

Large Diameter Valve Seat Wheels

- Specially designed bushing allows you to use stone with either angle toward workpiece
- Three abrasive formulations to choose from: General Purpose, Nickel Chrome, Cool Blue
- SXL wheels feature 30° on one face, 45° on the other



General Purpose		SX Double Angle 3/8"x14 thread		KW Single Angle 13/16"x13 thread	
Inch	mm	Jobber	Order No.	Jobber	Order No.
3"	76.2	\$23.49	SXL-2345-GP	\$26.99	KWL-2345-GP
3 1/4"	82.5	23.49	SXL-2445-GP	26.99	KWL-2445-GP
3 1/2"	88.9	23.49	SXL-2545-GP	26.99	KWL-2545-GP
3 3/4"	92.3	26.49	SXL-2645-GP	26.99	KWL-2645-GP
4"	101.6	26.49	SXL-2745-GP	26.99	KWL-2745-GP
Nickel Chrome		3/8"-14 thread		13/16"-13 thread	
Inch	mm	Jobber	Order No.	Jobber	Order No.
3"	76.2	\$22.79	SXL-2345-NC	\$26.99	KWL-2345-NC
3 1/4"	82.5	22.79	SXL-2445-NC	26.99	KWL-2445-NC
3 1/2"	88.9	22.79	SXL-2545-NC	26.99	KWL-2545-NC
3 3/4"	92.3	25.49	SXL-2645-NC	26.99	KWL-2645-NC
4"	101.6	25.49	SXL-2745-NC	26.99	KWL-2745-NC
Cool Blue		3/8"-14 thread		13/16"-13 thread	
Inch	mm	Jobber	Order No.	Jobber	Order No.
3"	76.2	\$23.49	SXL-2345-CB	\$26.99	KWL-2345-CB
3 1/4"	82.5	23.49	SXL-2445-CB	26.99	KWL-2445-CB
3 1/2"	88.9	23.49	SXL-2545-CB	26.99	KWL-2545-CB
3 3/4"	92.3	26.49	SXL-2645-CB	26.99	KWL-2645-CB
4"	101.6	26.49	SXL-2745-CB	26.99	KWL-2745-CB

Sioux-Style 1703 Valve Seat Stone Holder and .572" Top Pilots

• Use with SXXL-series Valve Seat Wheels below



Description	Jobber	Order No.
Sioux-Style Holder	\$209.99	SX-1703
.572" Top Pilots		
in	mm	
.562"	14.27	\$157.99 P-5562S
.563"	14.30	157.99 P-5563S
.564"	14.33	157.99 P-5564S
.625"	15.88	157.99 P-5625S
.626"	15.90	157.99 P-5626S
.627"	15.92	157.99 P-5627S
.628"	15.95	157.99 P-5628S

Extra Large Diameter SX Valve Seat Wheels

- 1" hole (no threads) • Double angle: 30° on one side; 45° on the other • Use with your Sioux-style 1703 stone holder

General Purpose		Nickel Chrome	
Inch	mm	Jobber	Order No.
4"	101.6	\$33.99	SXXL-2745-GP
4 1/4"	108.0	36.29	SXXL-2845-GP
4 1/2"	114.3	36.29	SXXL-2945-GP
4 3/4"	120.7	40.29	SXXL-3045-GP
5"	127.0	39.29	SXXL-3145-GP

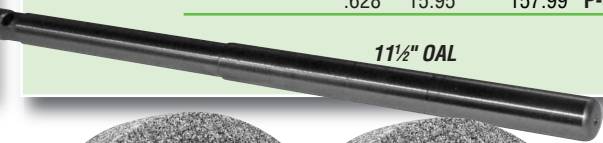

Heavy Duty Valve Seat Wheel Dresser



ABOVE: Easy to read scale is marked in 1° increments

BELOW: Positive locking adjustment levers stay where you set them

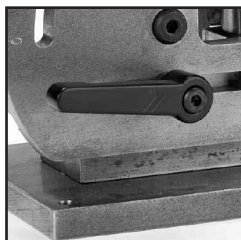

Includes Premium Diamond Dresser (G-13P)



Mounts to your bench for rigid, stable set-up



Rigid construction holds dresser firmly to produce a uniform finish



Riser Bushings are available to fit .385" and .572" top pilots



Built of tool blackened steel with a powder coated safety shield

Universal Design Dress a Wide Range of Stone Sizes

You'll never need to turn away business again because you don't have the ability to dress stones for grinding large seats. With the combined capacity of Goodson's Universal Dressing Stands you will be able to dress stones from 1/2" to 6" diameters.

Easy to use

These dressers are designed to be easy to use. Simply set your angles and go.

Built to Last

All steel construction on both models for years of reliable service.

Infinitely Adjustable

You can adjust your angle anywhere from 0° to 90° in 1° increments. If you need a 37° angle, you can do it. If you need a 42° angle, you can do that too.

Fully Assembled

Both Dressing Stands include the dressing diamond. The Heavy Duty unit (SWD-UNI-HD) also includes the .572" top dressing pilot and riser bushings. The Universal Dressing Stand (SWD-UNI) does not include the pilot so you can choose the correct 1 1/2" pilot for your application (.375", .385" or .437" top).

Ordering Information

Description	Jobber	Order No.
Universal Dressing Stand for Standard Diameter Wheels	\$519.99	SWD-UNI
Replacement Premium Dressing Diamond	61.99	G-13P
Dressing Stand Riser Bushings (.250" & .875" Tall)	8.99	SK-9-10
Dressing Stand Pilots		
.375" Top	35.99	P-5343N
will require shortening to work		
.385" Top	47.99	P-5343S
with the dressing stand		
.437" Top	55.99	P-5343K
Heavy Duty Universal Dressing Stand for Large Diameter Wheels	\$649.99	SWD-UNI-HD
Replacement Dressing Pilot (.572" Top)	69.99	SWD-1718-B
Replacement Premium Dressing Diamond	61.99	G-13P
Dressing Stand Riser Bushings (.250" & .875" Tall)	8.99	SK-11-12

See pages 14-19 for valve seat stones, stone holders, air drivers, etc.



WorldwideShipping

CYLINDER HEAD
REBUILDING

CLEANING,
ASSEMBLY & SAFETY

SHORT BLOCK
REBUILDING

CRANKSHAFT/
FLYWHEEL GRINDING

BRAKE & ALIGNMENT
TOOLS

MEASURING
TOOLS

OFFROAD BIKE, ATV
HARD PARTS

V-TWIN
HARD PARTS



These Adaptors will turn any 4 1/2" Angle grinder with 5/8" x 11 thread into a seat grinder.



Valve Seat Stone Holders & Accessories

- Ball-bearing stone holders • Ideal replacements for worn holders
- Save time by having several holders set up with commonly used sizes, composition or angles of seat stones

Stone Holders					
	Pilot Size	Thread	OE #	Jobber	Order No.
Original Kwik-Way	.437"	1 3/16"x13		\$291.29	KW-3056
Goodson OE Replacements					
Sioux-Style (Spline)	.385"	1 1/16"x16	1702	125.99	SX-HOLDER
Short Body (Spline)	.385"	1 1/16"x16	1672	104.99	SX-1672
5/8" Hex Drive	.385"	1 1/16"x16	1702BB	179.99	SX-1702BB
Leather Vibration Reducer (3 pc.) For SX-holders				10.99	SHW-3
Kwik-Way Style	.437"	1 3/16"-13	3056	164.99	KW-437
Leather Vibration Reducer (3 pc.) For KW-holders				10.99	KHW-3
Black & Decker Style	.375"	9/16"x16	BD-HOLDER	169.99	BDS-HOLDER
Includes adaptor to convert 9/16"x16 to 1 1/16"x16 Sioux-style stones					
Standard Bounce Spring Set				15.99	BSS-100
Seat Angle Grinder Adaptors		Sioux™		149.99	SW-SX
	5/8"x11 thread	Black & Decker		149.99	SW-BD
		Kwik-Way		149.99	SW-KW

Accessories			Jobber	Order No.
Black & Decker 5/8" Hexball	9/16"x24 thread		\$72.29	BD-58
	1 1/16"-16 Adaptor for Sioux™ stones		8.29	BD-60
Sioux™ Conversion Bushings	1 1/16"x16 to 7/8"x14		9.29	SX-78
Rebuild Kit for Kwik-Way OE Holder			\$159.99	KW-200 ▼
	Bearing (2 required)		18.79	KW-210
	Sleeve		75.99	KW-219
	Hex Grinder Body Cap		60.49	KW-295
	Key		24.99	KW-753
Replacement Parts for SGH Seat Grinder				
	Trigger Switch		46.79	KW-120
	Motor Hex Drive		72.79	KW-217
	Leather Washer		5.29	KW-941



Leather Vibration Reducers (see chart at left)
Replaces solid washers on holders.
SHW-3 is 3/16" thick and **KHW-3** is 1/8" thick

Valve Seat Height Gauge

- Adjusts for all popular valve seat diameters • Gauge accurate to .001"
- Seat contact probe aligns on valve seat while gauge rides along the fire deck • Pilot aligns in valve guide
- Fully adjustable seat contact probe and gauge positions allow tool to fit popular seat diameters from .750" to 3.00"



Description	Fits Pilot	Jobber	Order No.
Valve Seat Height Gauge Kit	.375"	\$92.99	VSHG-375
	.385"	92.99	VSHG-385
	.437"	92.99	VSHG-437
Replacement Dial Bore Gauge		28.99	EDI-1

Standard Bounce Spring Set

- Includes one each of three lengths:
1" / 24.5mm , 1 1/2" / 38.1mm and 2" / 50.8mm
- ID = .450" / 11.4mm • OD = .570" / 14.5mm
- Order No. **BSS-100** Jobber \$15.99



Small Diameter Springs

- ID = .406"/10.3mm • OD = .500"/12.7mm
- | Length / mm | Jobber | Order No. |
|--------------|--------|-------------|
| 1.10" / 27.9 | \$7.99 | BS-1 |
| 1.67" / 42.4 | 7.99 | BS-2 |
| 3.00" / 76.2 | 11.99 | BS-3 |

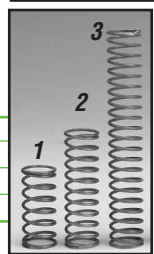

Pilots & Bushings For Sioux™ 1716 Seat Wheel Dresser

- Replacement parts for the popular 1716 Seat Wheel Dresser no longer available from Sioux™
- .375" top pilot features a groove for Black & Decker holders



Description	Jobber	Order No.
.385" Top Pilot	\$69.29	1718A
.375" Top Pilot	61.79	1718-BD
.572" Top Pilot for Sioux™ 1716 Dresser	69.99	1718-B
Riser Bushings (2) for .385" Pilots	8.99	SK-9-10
Riser Bushings (2) for .572" Pilots	8.99	SK-11-12

More replacement parts on page 109



Sioux-Style Seat Stone Removal Tool

Once in a while a valve seat stone will be so tight on the stone holder that it's almost impossible to get off. That's why we came up with this tool. Simply fasten it to your bench with screws or bolts (not included) or clamp it in a vise, set the holder onto the fixture and twist the stone off easily.
Order No. **SX-SRT** Jobber \$24.79



Valve Seat Grinder Kit

• Includes the supplies you need to get set up and grinding (driver sold separately) – choose from drivers at right

Description	Jobber	Order No.	Incl.
Sioux-Style Valve Seat Grinder Kit	\$1,489.99	SGK-385	▼
Universal Dressing Stand	499.99	SWD-UNI	1
3 Piece Bounce Spring Set	15.99	BSS-100	1
Sioux-Style Stone Holder	125.99	SX-HOLDER	2
.385" Top Solid Taper Pilot	Dia. mm		
	.275" 6.98	\$47.99	P-5275S 1
	.276" 7.00	47.99	P-5276S 1
	.277" 7.04	47.99	P-5277S 1
	.278" 7.06	47.99	P-5278S 1
	.312" 7.94	47.99	P-5312S 1
	.313" 7.95	47.99	P-5313S 1
	.314" 7.98	47.99	P-5314S 1
	.315" 8.00	47.99	P-5315S 1
	.343" 8.71	47.99	P-5343S 2
	.344" 8.74	47.99	P-5344S 1
	.345" 8.77	47.99	P-5345S 1
	.375" 9.53	47.99	P-5375S 1
	.376" 9.55	47.99	P-5376S 1
	.378" 9.60	47.99	P-5378S 1
Valve Seat Wheels	Angle Dia. mm	Jobber	
General Purpose	30°	1 3/8" 35	\$13.49 SX-1130-GP 1
		1 1/2" 38	13.49 SX-1230-GP 1
		1 5/8" 41	13.49 SX-1330-GP 1
		1 3/4" 44	13.49 SX-1430-GP 1
		1 7/8" 47	13.49 SX-1530-GP 1
		2" 51	13.49 SX-1630-GP 1
		2 1/8" 54	13.49 SX-1730-GP 1
	45°	1 3/8" 35	13.49 SX-1145-GP 1
		1 1/2" 38	13.49 SX-1245-GP 1
		1 5/8" 41	13.49 SX-1345-GP 1
		1 3/4" 44	13.49 SX-1445-GP 1
		1 7/8" 47	13.49 SX-1545-GP 1
		2" 51	13.49 SX-1645-GP 1
		2 1/8" 54	13.49 SX-1745-GP 1
Finishing	30°	1 3/8" 35	11.49 SX-1130-F 1
		1 1/2" 38	11.49 SX-1230-F 1
		1 5/8" 41	11.49 SX-1330-F 1
		1 3/4" 44	11.49 SX-1430-F 1
		1 7/8" 47	11.49 SX-1530-F 1
		2" 51	11.49 SX-1630-F 1
		2 1/8" 54	11.49 SX-1730-F 1
	45°	1 3/8" 35	11.49 SX-1145-F 1
		1 1/2" 38	11.49 SX-1245-F 1
		1 5/8" 41	11.49 SX-1345-F 1
		1 3/4" 44	11.49 SX-1445-F 1
		1 7/8" 47	11.49 SX-1545-F 1
		2" 51	11.49 SX-1645-F 1
		2 1/8" 54	11.49 SX-1745-F 1



Sioux-Style Spline Drive 90° Angle High-Speed Air Driver

- 1/4" air inlet • Max 1.0 HP
- 2 1/2" wheel capacity
- Weighs 5 1/2 lbs / 2.5 kg
- 10,000 RPM (governed)
- Order No. **1792AG**
- Jobber \$349.99

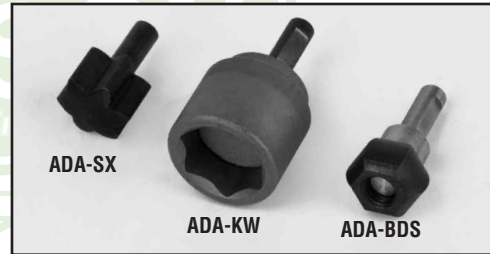

Use this 4500 RPM Air Driver vertically to reduce side load on wheels

- Weighs just 2 lbs./91 kg
- Adaptors available for a variety of wheels
- Precision clamping collet and wrenches included

Description	Jobber	Order No.
4500 RPM Air Driver	\$99.99	AG-4500
Hexball Driver	5/16" SAE thread	99.99 ADA-BDS
Kwik-Way Drive Adaptor (requires KW-217)	99.99	ADA-KW
Sioux™ Drive Adaptor	99.99	ADA-SX

Tooling Stand

- Room for up to five tools
- Accommodates tooling using 3/8" / 9.5mm and larger pilots
- Billet aluminum construction with non-marring cushions
- Ideal for 3-D Fast-Cut™ Ball Heads, stone holders, etc.
- Order No. **TS-5** Jobber \$29.99



CYLINDER HEAD REBUILDING
CLEANING, ASSEMBLY & SAFETY
SHORT BLOCK REBUILDING
FLYWHEEL GRINDING
CRANKSHAFT/ BRAKE & ALIGNMENT TOOLS
MEASURING TOOLS
OFFROAD BIKE, ATV HARD PARTS
V-TWIN HARD PARTS

Valve Refacing Wheels

Precision made wheels for superior performance on your machine

We stock more than 40 individual valve refacer wheels, each one designed for a specific machine. Our 4" general purpose wheel for Black & Decker is different from our 4" general purpose wheel for Sioux. We won't compromise on performance just to simplify our inventory. Your valve refacer requires a certain type of grit, grade and bond and Goodson delivers. Goodson guarantees all valve refacing wheels against manufacturing defects for 1 year from original purchase date.

Choose from these types: **S** = for grinding Stellite, **T** = for grinding Titanium, **GP** = for general purpose grinding and **CB** = for general purpose grinding of harder materials.

To Fit	Use	Dia x Ht x Arb	Shape	Type	Fits Models	OE No.	Jobber	Order No.
Black & Decker	Valve	4" x 1" x 5/8"	Offset	GP	A, B, C, LW, M,	33056	\$41.49	GV-146
Van Dorn	Valve	4" x 1" x 5/8"	Offset	CB	A, B, C, LW, M,	—	31.79	GV-146-CB
	Valve	4" x 1" x 5/8"	Offset	S	MW, N, NVW, NWB	16371	30.99	GV-144
	Valve	5" x 1" x 5/8"	Offset/20°	GP	P, PC, PCB, T, TD, TG	34131	44.99	GV-156
	Stem	4" x 1 1/8" x 1/2"	Cup	GP	All models	20939	29.29	GV-145
Comec	Valve	215 x 35 x 76mm	Flared	GP	VR416, RV-516	7604	129.49	GV-925
	Valve	215 x 35 x 76mm	Flared	T	VR416, RV-516	7603	109.49	GV-927
	Stem	100 x 50 x 20mm	Cup	GP	VR416, RV-516	7606	51.99	GV-928
IDL Sunnen	Valve	8" x 1 1/4" x 1 1/2"	Flared	GP	CG-50,-80,-82, V-90, VR-7000	8230	119.99	GV-823
	Valve	8" x 1 1/4" x 1 1/2"	Flared	GP	CG-50,-80,-82, V-90, VR-7000	VR1703	169.79	GV-825
	Valve	8" x 1 1/4" x 1 1/2"	Flared	S	CG-50,-80,-82, V-90, VR-7000	—	114.49	GV-821
	Valve	8" x 1 1/4" x 1 1/2"	Flared	S	CG-50,-80,-82, V-90, VR-7000	8230-3	105.99	GV-826
	Valve	8" x 1 1/4" x 1 1/2"	Flared	T	CG-50,-80,-82, V-90, VR-7000	VR1704	107.99	GV-827
	Stem	8" x 1 1/4" x 1 1/2"	Flared	GP	CG-80, CG-82, V-90, VR-7000	VR1701	103.99	GV-824
Kwik-Way	Valve	4" x 3/4" x 7/8"	Offset	GP	P, C, D, A	4001	26.99	GV-254
	Valve	4 1/2" x 7/8" x 7/8"	Offset	GP	CV, SK, KK, VC, SV, XC	4501	56.79	GV-257
	Valve	4 1/2" x 7/8" x 7/8"	Offset	S	CV, SK, KK, VC, SV, XC	4570	41.79	GV-259
	Valve	5" x 7/8" x 7/8"	Offset	GP	EVS, VS	—	51.79	GV-250
	Valve	5" x 7/8" x 7/8"	Offset	GP	EVS, VS	—	41.79	GV-251
	Valve	5" x 7/8" x 7/8"	Offset	GP	EVS, VS	5090	44.49	GV-252
	Valve	5" x 7/8" x 7/8"	Offset	S	EVS, VS	—	42.49	GV-249
	Valve	5" x 7/8" x 7/8"	Offset	S	EVS, VS	5070	49.79	GV-253
	Valve	5" x 7/8" x 7/8"	Offset	T	EVS, VS	5080	94.99	GV-255
	Valve	7" x 1" x 7/8"	Offset	GP	SVS, SVS-2	7090	56.29	GV-280
	Valve	7" x 1" x 7/8"	Offset	CB	SVS, SVS-2	—	69.29	GV-280-CB
	Valve	7" x 1" x 7/8"	Offset	S	SVS, SVS-2	—	91.99	GV-281
	Valve	7" x 1" x 7/8"	Offset	T	SVS, SVS-2	7080	159.99	GV-282
	Valve	7" x 1" x 5/8"	Offset	T	SVS, SVS-2	—	109.99	GV-282A
	Valve	8" x 1 3/8" x 7/8"	Offset	GP	VL	8100	89.99	GV-260
	Stem	3" x 1 1/4" x 5/8"	Cup	GP	All but VL	3000	20.29	GV-237
	Stem	3" x 1 1/4" x 5/8"	Cup	CB	All but VL	—	25.49	GV-237-CB

Colors may vary due to manufacturing processes. All valve refacing wheels are guaranteed for 1 year from original purchase date.



Valve Grinding Oil

- Long-lasting • Cools while grinding
- Removes particles for a better finish
- Inhibits rust • Prevents rancidity, foaming & deposits

Quantity	Jobber	Order No.
1 gallon / 3.79 L	\$ 29.99	VGO-10
5 gallons / 18.93 L	119.99	VGO-50

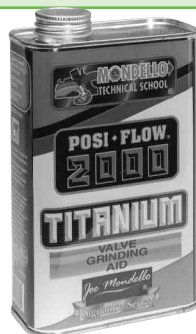

High-Performance Valve Grinding Aid For Titanium, Stainless & Stellite valves

- Grind to a mirror finish
- Seeks out, and bonds to hot metals
- Ideal for grinding hard metal racing valves • 32 oz. / 946 mL
- Order No. **VGA-T32** Jobber \$41.99



Valve Stem to Valve Face Concentricity Gauge

- Accurate to .001"
- Features a rugged, positive stop – set it once and do an entire set of valves
- Use before grinding to eliminate needless cleaning & machine time
- Use after resurfacing to ensure stem concentricity • Also check pilots and other small parts for concentricity
- For stems as small as 4mm
- Order No. **VCG-16** Jobber \$224.99



CYLINDER HEAD REBUILDING

CLEANING, ASSEMBLY & SAFETY

SHORT BLOCK REBUILDING

CRANKSHAFT/ FLYWHEEL GRINDING

BRAKE & ALIGNMENT TOOLS

MEASURING TOOLS

OFFROAD BIKE, ATV HARD PARTS

V-TWIN HARD PARTS

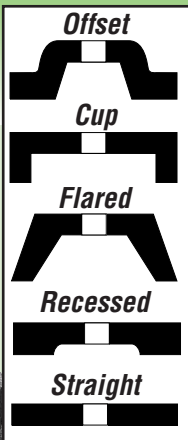

Choose the correct profile for your machine and application

Always check your dressing diamond before dressing your refacing wheels. See page 107 for our complete selection, including diamonds specifically for valve refacers.



To Fit	Use	Dia x Ht x Arb	Shape	Type	Fits Models	OE No.	Jobber	Order No.
KO Lee	Valve	5" x 3/4" x 5/8"	Offset	GP	All models	OV5GH60	\$69.29	GV-658
		5" x 3/4" x 5/8"	Offset	S	All models	OV5GH80S	49.99	GV-659
	Stem	4" x 1" x 5/8"	Cup	GP	K500(C) & K403(C)	RV4KH60	25.99	GV-345
		4" x 1" x 5/8"	Cup	CB	All but 500 & CRW	—	30.79	GV-345-CB
Rottler VR-7	Valve	7" x 1" x 7/8"	Offset	GP	—	VTRW-8	56.29	GV-280
	—	7" x 1" x 7/8"	Offset	T	—	VTRW-7	159.99	GV-282
	Stem	3" x 1 1/4" x 5/8"	Cup	GP	—	VTRW-9	20.29	GV-237
Rottler VR-8	Valve	8" x 1 1/4" x 1 1/2"	Flared	GP	—	—	159.99	GV-525
		8" x 1 1/4" x 1 1/2"	Flared	T	—	—	129.99	GV-527
	Stem	100 x 50 x 20mm	Cup	GP	VR416, RV-516	7606	51.99	GV-928
Skil Snap-On	Valve	5" x 3/4" x 5/8"	Offset	GP	All models	7556/VW80	61.29	GV-658
	—	5" x 3/4" x 5/8"	Offset	S	All models	VW80S	49.99	GV-659
—	Stem	4" x 1" x 5/8"	Cup	GP	All but Skil 491	7557/VR2M89	25.99	GV-345
		4" x 1" x 5/8"	Cup	CB	All but 500 & CRW	—	30.79	GV-345-CB
		4" x 1" x 5/8"	Cup	CB	All but 500 & CRW	—	30.79	GV-345-CB
Sioux™	Valve	4" x 1" x 5/8"	Offset	CB	All but 680, 682, 285, 956	—	31.79	GV-146-CB
		4" x 1" x 5/8"	Offset	GP	All but 680, 682, 285, 956	78SP	30.29	GV-147
		4" x 1" x 5/8"	Offset	GP	All but 680, 682, 285, 956	78E	49.49	GV-148
		4" x 1" x 5/8"	Offset	S	All but 680, 682, 285, 956	78A	32.49	GV-149
		4" x 1" x 5/8"	Offset	S	All but 680, 682, 285, 956	—	30.99	GV-144
		4" x 1" x 5/8"	Offset	T	All but 680, 682, 285, 956	—	46.79	GV-150
		5" x 1" x 5/8"	Offset/20°	GP	Thor 299 & 300	—	44.99	GV-156
		7" x 1 1/16" x 1 3/4"	Str./15°	GP	680, 956, 2001 & 2075	176	51.79	GV-270
		7" x 1 1/16" x 1 3/4"	Str./15°	CB	680, 956, 2001 & 2075	—	48.79	GV-270-CB
		7" x 1 1/16" x 1 3/4"	Str./15°	S	680, 956, 2001 & 2075	177	51.99	GV-271
		7" x 1 1/16" x 1 3/4"	Str./15°	T	680, 956, 2001 & 2075	174	119.79	GV-272
		Stem	4" x 1" x 5/8"	Cup	GP	All but 682 & 685	81 (73533)	25.99
4" x 1" x 5/8"	Cup		CB	All but 500 & CRW	—	30.79	GV-345-CB	
Sunnen (TA) S&D	Valve	6" x 1 1/16" x 3/4"	Flared	GP	VR6500, all S&D	VR602	129.99	GV-766
—	Stem	5" x 1 1/2" x 3/4"	Cup	GP	VR6500, all S&D	VR601	72.49	GV-755
Winona	Valve	5" x 3/4" x 5/8"	Off./Bev.	GP	E, Y, YW, X, XA	75399	69.29	GV-658
Van	—	5" x 3/4" x 5/8"	Off./Bev.	S	K500HM, K403CM	75400	49.99	GV-659
Norman	Valve	7" x 1 3/8" x 5/8"	Off./Bev.	GP	VRW	—	97.49	GV-424
		12" x 5/8" x 3"	Straight	GP	CRW, VR-1000	802003/24078	94.79	GV-409
		12" x 5/8" x 3"	Str./15°	S	VR-1000	805667	129.29	GV-410
	Stem	4" x 1" x 5/8"	Cup	GP	All but 500 & CRW	40352	25.99	GV-345
		4" x 1" x 5/8"	Cup	CB	All but 500 & CRW	—	30.79	GV-345-CB
—	—	10" x 1 1/4" x 3"	Recessed	GP	CRW	24079	129.29	GV-408

Colors may vary due to manufacturing processes. All valve refacing wheels are guaranteed for 1 year from original purchase date.

Optional VG-STOP for extra long stemmed valves



Adaptor for 1/2" Chucks

- Ideal for small diameter valves
- Hardened steel tool body fits any machine with a 1/2" chuck
- Collet seats in retainer nut for fast, easy removal
- Internal stop adjusts with a screwdriver, allowing you to reface an entire set of valves to identical specs quickly
- 4 collet sizes cover range of 4.0 - 6.5mm
- Start with the set then replace collets as needed (collets will not work without the holder) • Add the Adaptor Stop to machine longer valve stems with less deflection

Description Range	Jobber	Order No.	Incl.
Full Set	\$249.99	UVRC-46	▼
Replacement 4.5 - 5.0 mm (.177"-.196")	36.99	UVRC-5MM	x
Collets	5.0 - 5.5 mm (.196"-.216")	36.99	UVRC-5.5MM x
	6.0 - 6.5 mm (.236"-.256")	36.99	UVRC-6.5MM x
	4.0mm (.157") sold separately	36.99	UVRC-4MM
Adaptor Stop Sold Separately	13.49	VG-STOP	

Collet for Black & Decker® Valve Refacers

- Two-piece set
- Replaces the Black & Decker Twin Grip collet (no longer available)
- Remove the damaged, worn or broken collet and replace with this set • Fits 1/4" - 3/8" (6.35-9.53mm) valve stems
- Order No. **BVR-38** Jobber \$169.99

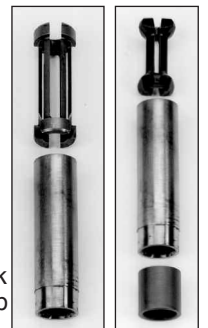

▲ Collet is unavailable from OE
▲ Replace with two-piece set

More Valve Refacer Replacement Parts are shown on page 109

Piloted Core Drills and Reamers

• CNC-machined to .0003" T.I.R. or less • Ideal for any Bridgeport-type (collet driven) machine • Use dry at 175 to 225 PRM

Piloted Core Drills

- Center accurately in the guide • Cutting angle prevents the bit from wandering due to irregular guide wear • Flutes are designed to enlarge bores quickly • Manufactured to close tolerances of concentricity

Precision Reamers

- Pilot size is carefully matched to the OD of the corresponding core drill • Assures accurate location of the reamer for smooth, vibration free operation • Gives proper interference fit to match manufacturer specifications

Core Drills

Core Reamers

	OD	Pilot	Orig. No.	Jobber	Order No.	OD	Orig. No.	Jobber	Order No.
DCM Tech,	.4687"	.312"	DP-1550	\$ 99.99	DPP-1511B	.500"	66-02147, RR-115	\$ 99.99	DRR-115
Peterson /	.4687"	.344"	66-02138, DP-1511	99.99	DPP-1511	.500"	66-02147, RR-115	99.99	DRR-115
Kansas	.4687"	.375"	66-02140, DP-1530	99.99	DPP-1530	.500"	66-02147, RR-115	99.99	DRR-115
Instruments	.5312"	.375"	DP-1730	99.99	DPP-1530A	.5625"	66-02148, RR-916	99.99	DRR-916
½" Round	.5937"	.375"	66-02144, DP-1930	99.99	DPP-1970B	.625"	66-02149, RR-519	99.99	DRR-519
Shank	.5937"	.438"	66-02145, DP-1970	99.99	DPP-1970	.625"	66-02149, RR-519	99.99	DRR-519
Sunnen™ /	.490"	.312"	VGS-156A	99.99	DTA-2082B	.500"	VGS-162A	99.99	DRT-2097
Tobin-Arp	.490"	.343"	VGS-152A	99.99	DTA-2082	.500"	VGS-162A	99.99	DRT-2097
½" with Flat	.490"	.371"	VGS-153A	99.99	DTA-2083	.500"	VGS-162A	99.99	DRT-2097
Winona	.4687"	.344"	804206	96.99	DD-1532-G	.500"	804237	99.99	DR-500-G
Van Norman	.4687"	.375"	804207	96.99	DD-1532A-G	.500"	804237	99.99	DR-500-G
IDL /	.412"	.310"	501002	86.99	DVN-1				
Van Norman	.475"	.341"	501003	87.99	DVN-2	.500"	501011	99.99	DRV-79
¾" Sq. Drive	.475"	.375"	501004	87.99	DVN-3	.500"	501011	99.99	DRV-79
Universal	.429"	7mm		147.99	CCD-59	.4365"		129.99	FCR-60-1
.429" Round	.429"	7mm		147.99	CCD-59	.4375"		129.99	FCR-60
Shank	.429"	7mm		147.99	CCD-59	.4995"		147.99	CCR-59
			Super Reamer -enlarge damaged guide bores			.562"	.500" pilot see p.27 for guides	147.99	CCR-562B



Note: For the best performance, Core Drills and Reamers should be used in matched pairs. If you order a drill slightly smaller or larger than the OE specification to fit your machine, please order the matching reamer listed immediately to the right of the drill in the table.

High Speed Steel Core Drill/Reamers

- Save time – drill and ream in a single pass
- Top-quality, high speed steel
- Prepares the guide bore for standard ½" OD valve guide inserts
- Several shank designs to fit most Seat & Guide machines

Fits	Size	mm	Jobber	Order No.
Winona Van Norman	.343" x .500"	8.7x12.7	\$159.99	CDR-6055G
.468" flat	.375" x .500"	9.5x12.7	159.99	CDR-6056G
Tobin-Arp & Sunnen	.343" x .500"	8.7x12.7	159.99	CDR-6105G
Peterson and K.I.	.343" x .500"	8.7x12.7	159.99	CDR-6196G
½" round shank	.375" x .500"	9.5x12.7	159.99	CDR-6197G
Kwik-Way and DCM	.343" x .500"	8.7x12.7	159.99	CDR-6211G
½" round shank	.375" x .500"	9.5x12.7	159.99	CDR-6212G
IDL ¾" square w/.500"	.343" x .500"	8.7x12.7	159.99	CDR-6762G
Serdi	.275" x .437"	7.0x11.1	159.99	CDR-7192G
¾" with flat	.275" x .500"	7.0x12.7	159.99	CDR-7193G
	.312" x .437"	7.9x11.1	159.99	CDR-7194G
	.312" x .500"	7.9x12.7	159.99	CDR-7195G
	.343" x .500"	8.7x12.7	159.99	CDR-7196G
	.375" x .500"	9.5x12.7	159.99	CDR-7197G
Cobalt Core Drills/ Reamers	Size	mm	Jobber	Order No.
½" round shank	.312" x .500"	7.92x12.7	\$169.99	CDR-312-CB
	.343" x .500"	8.71x12.7	169.99	CDR-343-CB
	.375" x .500"	9.53x12.7	169.99	CDR-375-CB

Check these other tools for diesel applications

Air Powered Valve Guide Drivers	page 26
Valve Guides	page 27
Valve Seals.....	page 33
Pneumatic Valve Spring Compressor.....	page 34
Heat Tabs.....	page 50



Valve Guide Tooling For 24 Valve, 7mm Cummins

- To replace integral guides used in this diesel cylinder head
- Replacement guides are .502/.511" stepped to use with OE or replacement seals below

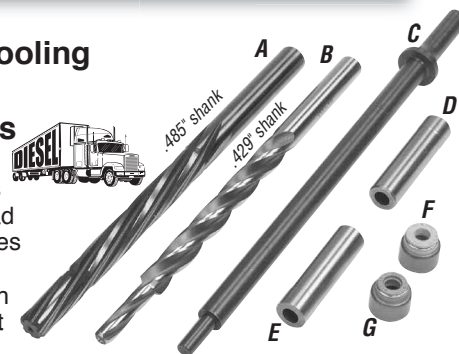

Description	Jobber	Order No.	Includes
Complete Kit	\$399.99	CVG-KIT	▼
Tooling Kit Only	299.99	CVG-59KIT	▼
A Core Reamer (.426" pilot, .485" shank)	147.99	CCR-59	1 1
B Core Drill (7mm pilot, .429" shank)	147.99	CCD-59	1 1
C Guide Driver (7.0mm)	22.79	PHL-2235-G	1 1
D Cast Iron Valve Guide (Exhaust)	2.99	CIG-3022	12
E Cast Iron Valve Guide (Intake)	3.29	CIG-3021	12
F Exhaust Seals (12 pk.)	16.99	CVS-59E	1
G Intake Seals (12 pk.)	16.99	CVS-59I	1

Use **WSR-41-3-G** (1/4" sq.) or **WSR-41-4-G** (3/16" sq.) with **WSR-41-7-G** (3/8" drill adaptor). Clamp 3/8" drive in drill to drive reamers directly. Quickly install and remove in use.

Quart Bronze Reaming Oil

• Order No. **BW-303A-G**
Jobber \$15.99



Small Reamers for Cast Iron or Bronze

Premium quality reamers with tough cobalt flutes for long life in cast iron or bronze.

1/8" Square Drive

Inch	mm	Order No.
.1565"	3.98	MR-156
.1575"	4.00	MR-4MM
.1585"	4.03	MR-158
.1760"	4.47	MR-176
.1771"	4.50	MR-4.5MM
.1780"	4.52	MR-178
.1960"	4.98	MR-196
.1968"	5.00	MR-5.0MM
.1980"	5.03	MR-198

Jobber \$65.99

Titanium Coated Cobalt Reamers

- Smooth and precise
- Less brittle than carbide
- Ideal for use on cast iron

3/16" Square Drive

Inch	mm	Order No.
.2165"	5.50	TNR-5.5MM-B
.236"	6.00	TNR-6MM-B
.248"	6.30	TNR-248-B
.249"	6.32	TNR-249-B
.250"	6.35	TNR-250-B
.2755"	7.00	TNR-7MM-B

1/4" Square Drive

Inch	mm	Order No.
.312"	7.92	TNR-312-B
.315"	8.00	TNR-8MM-B
.340"	8.64	TNR-340-B
.341"	8.66	TNR-341-B
.342"	8.69	TNR-342-B
.343"	8.71	TNR-343-B
.344"	8.74	TNR-344-B
.354"	9.00	TNR-9MM-B
.373"	9.47	TNR-373-B
.374"	9.50	TNR-374-B
.375"	9.52	TNR-375-B
.376"	9.55	TNR-376-B
.377"	9.58	TNR-377-B
.378"	9.60	TNR-378-B

Jobber \$79.99

Solid Carbide Valve Guide Reamers
Specifically designed for use with bronze guides only

- Features an extended pilot and multi-fluted design so you can size guides perfectly
- One size allows you to fit both intake & exhaust when using AV&V valves and guides
- 300 to 400 RPM is recommended.
- Use with Bronze Reaming Oil (**BW-303A-G**)
- **DO NOT** use on cast iron

Dia.	Jobber	Order No.	Dia.	Jobber	Order No.
4.0mm	\$189.99	HGR-4.0MM	.3160"	\$249.99	HGR-3160
4.5mm	189.99	HGR-4.5MM	.3410"	249.99	HGR-3410
5.0mm	189.99	HGR-5.0MM	.3420"	249.99	HGR-3420
5.5mm	189.99	HGR-5.5MM	.3425"	249.99	HGR-3425
6.0mm	249.99	HGR-6MM	.3430"	249.99	HGR-3430
6.5mm	249.99	HGR-6.5MM	.3435"	249.99	HGR-3435
6.6mm	249.99	HGR-6.6MM	.3440"	249.99	HGR-3440
7.0mm	249.99	HGR-7MM	.3450"	249.99	HGR-3450
.2766"	249.99	HGR-2766	.3540"	249.99	HGR-3540
.3100"	249.99	HGR-3100	.3720"	249.99	HGR-3720
.3110"	249.99	HGR-3110	.3730"	249.99	HGR-3730
.3115"	249.99	HGR-3115	.3740"	249.99	HGR-3740
.3120"	249.99	HGR-3120	.3750"	249.99	HGR-3750
.3130"	249.99	HGR-3130	.3777"	249.99	HGR-3777
.3140"	249.99	HGR-3140	.3782"	249.99	HGR-3782
8.0mm	249.99	HGR-8MM			

Due to the characteristics of carbide, we can only guarantee the reamer's dimensional accuracy.

High Speed Finish Reamers for Cast Iron

High quality finish reamers to precision size cast iron guides. Piloted and made from the finest tempered steel. With proper care, these reamers will accurately size multiple guides without losing their efficient cutting action. Not for hardened guides.

3/16" Square Drive

Inch	mm	Jobber	Order No.
.2165"	5.50	\$39.99	WR-5.5MM-G
.217"	5.51	39.99	WR-217-G
.218"	5.54	39.99	WR-218-G
.236"	6.00	39.99	WR-6MM-G
.250"	6.35	39.99	WR-250-G
.256"	6.50	39.99	WR-6.5MM-G
.257"	6.53	39.99	WR-257-G
.258"	6.55	39.99	WR-258-G
.259"	6.58	39.99	WR-259-G
.260"	6.60	39.99	WR-260-G
.261"	6.63	39.99	WR-261-G
.273"	6.93	39.99	WR-273-G
.274"	6.96	39.99	WR-274-G
.275"	6.99	39.99	WR-275-G
.2755"	7.00	39.99	WR-7MM-G
.276"	7.01	39.99	WR-276-G
.277"	7.03	39.99	WR-277-G
.278"	7.06	39.99	WR-278-G
.279"	7.09	39.99	WR-279-G
.281"	7.14	41.99	WR-281-G

1/4" Square Drive

Inch	mm	Jobber	Order No.
.316"	8.03	\$41.99	WR-316-G
.317"	8.05	41.99	WR-317-G
.318"	8.08	41.99	WR-318-G
.327"	8.31	42.99	WR-327-G
.328"	8.33	42.99	WR-328-G
.334"	8.48	42.99	WR-8.5MM-G
.340"	8.64	42.99	WR-340-G
.341"	8.66	42.99	WR-341-G
.342"	8.69	42.99	WR-342-G
.343"	8.71	42.99	WR-343-G
.3435"	8.72	42.99	WR-3435-G
.344"	8.74	42.99	WR-344-G
.345"	8.76	42.99	WR-345-G
.346"	8.79	42.99	WR-346-G
.347"	8.81	42.99	WR-347-G
.348"	8.84	42.99	WR-348-G
.353"	8.97	42.99	WR-353-G
.354"	9.00	42.99	WR-9MM-G
.355"	9.02	42.99	WR-355-G
.356"	9.04	42.99	WR-356-G
.358"	9.09	43.99	WR-358-G
.371"	9.42	43.99	WR-371-G
.372"	9.45	43.99	WR-372-G
.373"	9.47	43.99	WR-373-G
.374"	9.50	43.99	WR-374-G
.375"	9.52	43.99	WR-375-G

1/4" Square Drive

Inch	mm	Jobber	Order No.
.376"	9.55	\$43.99	WR-376-G
.377"	9.58	43.99	WR-377-G
.378"	9.60	43.99	WR-378-G
.379"	9.63	43.99	WR-379-G
.380"	9.65	43.99	WR-380-G
.386"	9.80	43.99	WR-386-G
.388"	9.86	45.99	WR-388-G
.390"	9.91	45.99	WR-390-G
.393"	9.98	45.99	WR-393-G
.394"	10.00	45.99	WR-10MM-G
.395"	10.03	45.99	WR-395-G
.404"	10.26	47.99	WR-404-G
.405"	10.29	47.99	WR-405-G
.406"	10.31	49.99	WR-406-G
.433"	11.00	49.99	WR-11MM-G
.435"	11.05	49.99	WR-435-G
.436"	11.07	49.99	WR-436-G
.437"	11.10	49.99	WR-437-G
.453"	11.51	51.99	WR-453-G
.472"	12.00	51.99	WR-12MM-G
.496"	12.60	51.99	WR-496-G
.499"	12.67	51.99	WR-499-G
.500"	12.70	51.99	WR-500-G
.502"	12.75	53.99	WR-502-G

If you need a different size, give us a call at 800-533-8010 to inquire about a special order.



Exclusive



No more guesswork!
Easy to read and easy to use feed knob. Each witness mark equals approximately .001" increase in hone diameter.

- Largest range of any guide hone
- Diamond abrasive delivers the finish required for today's valve guides
- Balanced yoke and body for symmetrical honing at any speed
- Size range replaces over 80 reamers!

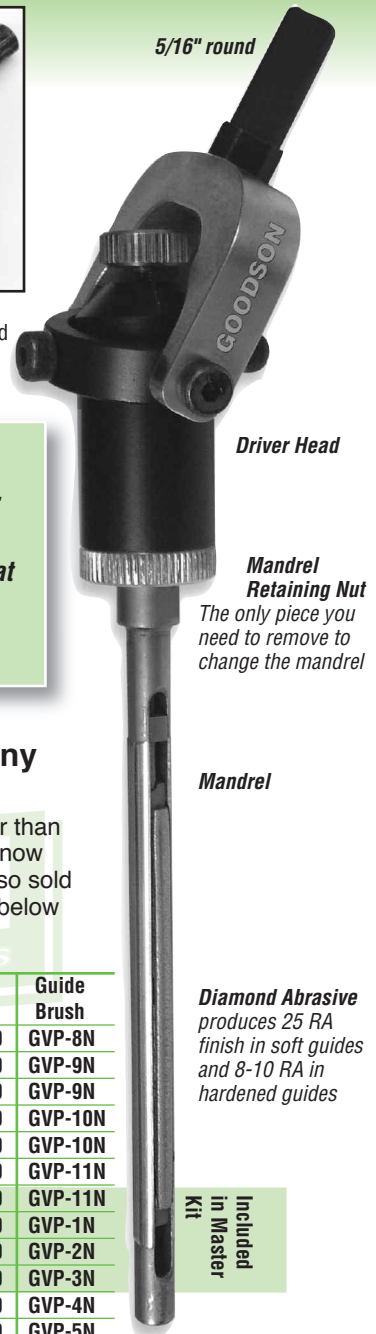

5/16" round

Driver Head

Mandrel Retaining Nut

The only piece you need to remove to change the mandrel

Mandrel

Diamond Abrasive produces 25 RA finish in soft guides and 8-10 RA in hardened guides

Included in Master Kit

Hyper-Finish Diamond Sizing System has the largest range of any guide hone on the market today

Goodson's exclusive Hyper-Finish Diamond Valve Guide Sizing System is bigger and better than ever. You asked for more sizes and we've delivered! With this easy-to-use system you can now size guides from .154" to .566" (3.9 -14.40mm) just by switching out mandrels. Mandrels also sold individually. The Drive Head (**HF-100**) fits every size mandrel assembly shown in the chart below and features a Quick Change set-up.

Size	Range		Mandrel Assembly (abrasive & mandrel)	Abrasive Length	Abrasive Only	Mandrel Only	Drive Head	Guide Brush
	inch	mm						
4.0mm	.154"-.164"	3.90 - 4.15mm	\$299.99 HFM-154C	20mm	HFS-154	HFM-154	HF-100	GVP-8N
4.5mm	.173"-.183"	4.40 - 4.90mm	299.99 HFM-173C	20mm	HFS-173	HFM-173	HF-100	GVP-9N
5.0mm	.193"-.203"	4.90 - 5.15mm	299.99 HFM-193C	40mm	HFS-193	HFM-193	HF-100	GVP-9N
5.5mm	.212"-.232"	5.40 - 5.90mm	299.99 HFM-212C	40mm	HFS-212	HFM-212	HF-100	GVP-10N
6.0mm	.232"-.253"	5.90 - 6.40mm	299.99 HFM-232C	40mm	HFS-232	HFM-232	HF-100	GVP-10N
6.5mm	.251"-.271"	6.40 - 6.90mm	299.99 HFM-251C	40mm	HFS-251	HFM-251	HF-100	GVP-11N
7.0mm	.271"-.311"	6.90 - 7.90mm	329.99 HFM-271C	80mm	HFS-271	HFM-271	HF-100	GVP-11N
5/16"	.307"-.347"	7.80 - 8.80mm	299.99 HFM-307C	80mm	HFS-307	HFM-307	HF-100	GVP-1N
11/32"	.334"-.374"	8.50 - 9.50mm	299.99 HFM-344C	80mm	HFS-344	HFM-344	HF-100	GVP-2N
3/8"	.350"-.389"	8.90 - 9.90mm	299.99 HFM-350C	80mm	HFS-350	HFM-350	HF-100	GVP-3N
10.0mm	.389"-.429"	9.90 - 10.90mm	299.99 HFM-394C	80mm	HFS-394	HFM-394	HF-100	GVP-4N
11.0mm	.429"-.507"	10.90 - 12.90mm	299.99 HFM-429C	80mm	—	—	HF-100	GVP-5N
12.5mm	.488"-.566"	12.40 - 14.40mm	499.99 HFM-488C	80mm	—	—	HF-100	GVP-6N
Jobber					\$149.99	\$199.99	\$299.99	\$6.29

Choose from the Standard Master Kit or Build Your Own!

Standard Master Kit includes: Driver Head, 4-Mandrel Assemblies (see chart above), 4-Nylon Valve Guide Brushes (7mm to 3/8") and 8 oz. Diamond Honing Oil. Order No. **HF-KIT** Jobber \$1,399.99

Custom Kit includes: Driver Head, 4-Mandrel Assemblies (select from chart above, **excluding 12.5mm**), 4-Nylon Valve Guide Brushes (you pick the sizes - see chart above) and 8 oz. Diamond Honing Oil. Order No. **HF-KIT-CUSTOM** Jobber \$1,399.99



Diamond Honing Oil

For high pressure honing

Size	Jobber	Order No.
8 oz.	\$ 4.99	DHO-8
1 Gallon	28.99	DHO-10
5 Gallons	124.99	DHO-50

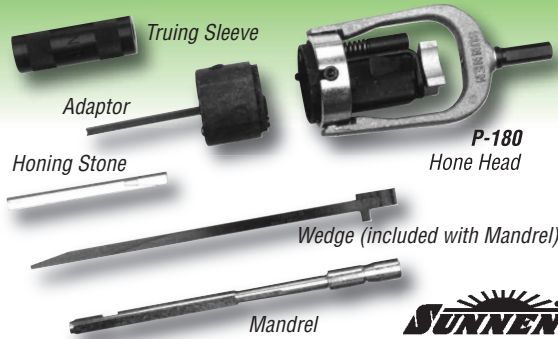

Valve Guide Resizing

Valve Guide Hone Set

- Sets-up fast • Easy to use! • Produces straight, round holes for top-quality work • Ideal for high-performance applications
- Use a low RPM, 1/2" drill for driving power (200 RPM max.)

Ordering Information: The head and driver are interchangeable with the adaptors. Only one head and driver is required. Mandrels are available to cover all popular sizes. Please select from the parts in the photo above and order per size range desired. We suggest you have an adaptor for each mandrel to save change-over time between mandrels.

Description	Jobber	Order No.
Sunnen Honall® Valve Guide Hone Set	\$699.99	P-190
Includes: Head & Driver. Mandrels & Sleeves (1 of ea. for sizes – 5/16", 1/2", 3/8", & 7/16")		
Adaptors: (1) PK10-A & (1) PK12-A. Stones L10-J69 & L12-J67. Case & instructions		
Sunnen Honall® Valve Guide Hone Head & Driver only	\$294.99	P-180

Size	Range		Mandrel		Sleeve		Roughing Stones		Finishing Stones		Adaptor		Stone Retainer
	Inch	mm	Jobber	Order No.	Jobber	Order No.	Jobber	Order No.	Jobber	Order No.	Jobber	Order No.	Jobber Order No.
3/16"	.185"-.190"	4.7-4.8	\$34.99	BL6-185CS	\$9.49	S-185	\$58.49	L6-J47 (12)	\$58.49	L6-J67 (12)	\$73.49	PSK6-A*	\$11.99 LN-3087C
	.190"-.195"	4.8-4.9	34.99	BL6-190CS	9.49	S-190	58.49	L6-J47 (12)	58.49	L6-J67 (12)	73.49	PSK6-A*	11.99 LN-3087C
5mm	.195"-.200"	4.9-5.1	34.99	BL6-195CS	9.49	S-195	58.49	L6-J47 (12)	58.49	L6-J67 (12)	73.49	PSK6-A*	11.99 LN-3087C
	.200"-.205"	5.1-5.2	34.99	BL6-200CS	9.49	S-200	58.49	L6-J47 (12)	58.49	L6-J67 (12)	73.49	PSK6-A*	11.99 LN-3087C
	.205"-.210"	5.2-5.3	34.99	BL6-205CS	9.49	S-205	58.49	L6-J47 (12)	58.49	L6-J67 (12)	73.49	PSK6-A*	11.99 LN-3087C
5.5mm	.210"-.215"	5.3-5.5	34.99	BL6-210CS	9.49	S-210	58.49	L6-J47 (12)	58.49	L6-J67 (12)	73.49	PSK6-A*	11.99 LN-3087C
	.215"-.220"	5.5-5.6	34.99	BL6-215CS	9.49	S-215	58.49	L6-J47 (12)	58.49	L6-J67 (12)	73.49	PSK6-A*	11.99 LN-3087C
	.225"-.230"	5.7-5.8	34.99	BL6-225CS	9.49	S-225	58.49	L6-J47 (12)	58.49	L6-J67 (12)	73.49	PSK6-A*	11.99 LN-3087C
6mm	.230"-.235"	5.8-6.0	34.99	BL6-230CS	9.49	S-230	58.49	L6-J47 (12)	58.49	L6-J67 (12)	73.49	PSK6-A*	11.99 LN-3087C
	.235"-.240"	6.0-6.1	34.99	BL6-235CS	9.49	S-235	58.49	L6-J47 (12)	58.49	L6-J67 (12)	73.49	PSK6-A*	11.99 LN-3087C
1/4"	.240"-.245"	6.1-6.2	34.99	BL6-240CS	9.49	S-240	58.49	L6-J47 (12)	58.49	L6-J67 (12)	73.49	PSK6-A*	11.99 LN-3087C
	.245"-.250"	6.2-6.4	37.49	BL8-245AS	9.49	S-245	33.99	L8-J47 (6)	34.99	L8-J67 (6)	61.99	PK8-A	---
6.6mm	.250"-.255"	6.4-6.5	37.49	BL8-250AS	9.49	S-250	33.99	L8-J47 (6)	34.99	L8-J67 (6)	61.99	PK8-A	---
	.255"-.260"	6.5-6.6	37.49	BL8-255AS	9.49	S-255	33.99	L8-J47 (6)	34.99	L8-J67 (6)	61.99	PK8-A	---
7mm	.270"-.275"	6.8-7.0	37.49	BL8-270AS	9.49	S-270	33.99	L8-J47 (6)	34.99	L8-J67 (6)	61.99	PK8-A	---
	.275"-.280"	7.0-7.1	37.49	BL8-275AS	9.49	S-275	33.99	L8-J47 (6)	34.99	L8-J67 (6)	61.99	PK8-A	---
*5/16"	.308"-.316"	7.8-8.0	39.99	BL10-308AS	10.29	S-308	34.99	L10-J47 (6)	34.99	L10-J69 (6)	61.99	PK10-A	---
*1 1/32"	.339"-.347"	8.6-8.8	46.99	BL10-339AS	10.29	S-339	34.99	L10-J47 (6)	34.99	L10-J69 (6)	61.99	PK10-A	---
*3/8"	.354"-.362"	9.0-9.2	38.49	BL10-354AS	10.29	S-354	34.99	L10-J47 (6)	34.99	L10-J69 (6)	61.99	PK10-A	---
*3/8"	.370"-.385"	9.4-9.8	46.99	BL12-370AS	12.49	S-370	34.99	L12-J47 (6)	34.99	L12-J67 (6)	61.79	PK12-A	---
*7/16"	.432"-.447"	11.0-11.4	39.49	BL12-432AS	12.49	S-432	34.99	L12-J47 (6)	34.99	L12-J67 (6)	61.79	PK12-A	---
*9/16"	.557"-.588"	14.1-14.9	54.49	BL16-557AS	13.49	S-557	42.29	L16-J47 (6)	41.29	L16-J67 (6)	61.99	PK16-A	---
*5/8"	.619"-.650"	15.7-16.5	58.49	BL20-619AS	15.49	S-619	42.99	L20-J47 (6)	42.99	L20-J67 (6)	61.49	PAK20-A	---

*Included in set *NOTE: Remove the stone retainer included with the PSK6-A and replace with LN-3087C for valve guide honing

Valve Guide OD Machining Tool Does 3 jobs at one time!

- Face the guide top to the correct size • Sizes the guide OD for press-on seals • Chamfers the top to prevent seal damage • Cutters & pilots are interchangeable and chuck into any portable drill, drill press or seat & guide machine

Valve Spring Seat Cutters on page 38

Individual Cutters

Guide OD	Order No.
.415"	VSC-415
.420"	VSC-423
.428"	VSC-428
.475"	VSC-475
.495"	VSC-495
.500"	VSC-500
.530"	VSC-530
.562"	VSC-562
.625"	VSC-625

Jobber \$66.99

Pilots

Guide ID	Order No.
5/32"	VP-7MM
3/16"	VP-312
1 1/32"	VP-343
3/8"	VP-375

Jobber \$19.99

Cutter and Pilot Assemblies

Guide OD	Pilot Size	Order No.
.415"	5/16"	7.9 VSC-415312
.420"	5/16"	7.9 VSC-420312
.428"	5/16"	7.9 VSC-428312
.475"	9/32"	7.0 VSC-475275
.475"	5/16"	7.9 VSC-475312
.495"	1 1/32"	8.7 VSC-495343*
.500"	5/16"	7.9 VSC-500312
.500"	1 1/32"	8.7 VSC-500343
.500"	12.7	3/8" 9.5 VSC-500375
.530"	13.5	5/16" 7.9 VSC-530312
.530"	13.5	1 1/32" 8.7 VSC-530343
.530"	13.5	3/8" 9.5 VSC-530375
.562"	14.3	5/16" 7.9 VSC-562312
.562"	14.3	1 1/32" 8.7 VSC-562343
.562"	14.3	3/8" 9.5 VSC-562375
.625"	15.9	3/8" 9.5 VSC-625375

Jobber \$79.99 *For Vortec, see page 32



Valve Guide OD Chamfer Tool

- Improve oil deflection
- Universal cutter chamfers any OD from 1/4" to 5/8" (6.35-15.9mm) • Most precise when used in a Seat and Guide Machine
- Order No. GCT-35 Jobber \$59.99

Valve Guide Top Collar

- Supports guide top during machining
- Protects against damage or breakage
- Ideal for high-performance work, and for installing Bronze-Wall® guide inserts or thin-wall liners

Size	Range	Jobber	Order No.
.500"	.496"-.504"	\$8.79	VGC-502
.530"	.526"-.534"	8.79	VGC-530
.566"	.562"-.570"	8.79	VGC-566



same day shipping

CYLINDER HEAD REBUILDING

CLEANING, ASSEMBLY & SAFETY

SHORT BLOCK REBUILDING

CRANKSHAFT/ FLYWHEEL GRINDING

BRAKE & ALIGNMENT TOOLS

MEASURING TOOLS

OFFROAD BIKE, ATV HARD PARTS

V-TWIN HARD PARTS

Valve Guide Replacement

1° negative angle prevents guides from spreading



Proper clearance for best contact and easy removal

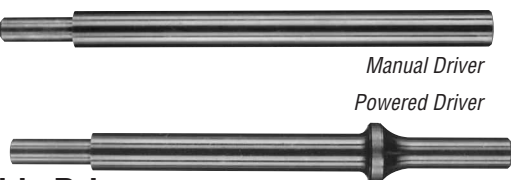

Manual Driver

Powered Driver

Valve Guide Drivers

- Corrosion-resistant finish
- Rockwell hardness of 45-50 • Pilots are slightly smaller than guide ID for easy removal • Powered Drivers have a 6" overall length • Manual Drivers have a 6.5" overall length

Powered Drivers

Standard Sizes	Jobber	Order No.	Incl.
4-piece Kit	\$61.99	PH-2226-G	▼
Guide ID /mm Driver OD Pilot			
.312" / 7.92 .487" / 12.4 .300" / 7.62	\$19.79	PH-2228A-G	
.312" / 7.92 .423" / 10.7 .304" / 7.72	19.79	PH-2228-G	x
.343" / 8.71 .487" / 12.4 .337" / 8.56	19.79	PH-2229-G	x
.372" / 9.47 .487" / 12.4 .367" / 9.32	19.79	PH-2231-G	x
.437" / 11.10 .612" / 15.5 .429" / 10.90	19.79	PH-2230-G	x

Metric Sizes	Jobber	Order No.	Incl.
6-piece Kit	\$89.99	PH-2600-G	▼
Guide ID /in. Driver OD Pilot			
5.0mm / .196" 9.0 / .355" 4.75 / .187"	\$19.79	PH-2250-G	x
5.5mm / .217" 10.5 / .412" 5.21 / .205"	19.79	PH-2255-G	x
6.0mm / .236" 10.5 / .412" 5.72 / .225"	19.79	PH-2260-G	x
6.6mm / .260" 11.8 / .463" 6.30 / .248"	19.79	PH-2234-G	x
7.0mm / .275" 11.0 / .432" 6.60 / .260"	19.79	PH-2235-G	x
8.0mm / .315" 11.7 / .462" 7.80 / .307"	19.79	PH-2236-G	x
9.0mm / .353" 12.4 / .487" 8.81 / .347"	19.79	PH-2237-G	
10mm / .393" 15.5 / .612" 8.56 / .387"	19.79	PH-2238-G	
11mm / .433" 15.5 / .612" 10.85 / .427"	19.79	PH-2239-G	

Manual Drivers

Standard Sizes	Jobber	Order No.	Incl.
4-piece Kit	\$58.99	GP-500A-G	▼
Guide ID /mm Driver OD Pilot			
.312" / 7.92 .422" / 10.7 .305" / 7.75	\$18.79	GP-431-G	x
.312" / 7.92 .487" / 12.4 .302" / 7.67	18.79	GP-531-G	x
.343" / 8.71 .487" / 12.4 .336" / 8.53	18.79	GP-534-G	x
.372" / 9.47 .487" / 12.4 .367" / 9.32	18.79	GP-537-G	x
.437" / 11.10 .611" / 15.5 .428" / 10.87	18.79	GP-743-G	

Metric Sizes	Jobber	Order No.	Incl.
6-piece Kit	\$79.99	GP-600M-G	▼
Guide ID /in. Driver OD Pilot			
6.6mm / .260" 11.7 / .462" 6.22 / .245"	\$18.79	GP-6.6MM-G	x
7mm / .275" 10.7 / .422" 6.78 / .267"	18.79	GP-7MM-G	x
8mm / .315" 12.3 / .486" 7.77 / .306"	18.79	GP-8MM-G	x
9mm / .353" 12.3 / .485" 8.84 / .348"	18.79	GP-9MM-G	x
10mm / .393" 15.5 / .611" 9.80 / .386"	18.79	GP-10MM-G	x
11mm / .433" 15.5 / .611" 10.82 / .426"	18.79	GP-11MM-G	x



Extra-Long Valve Guide Drivers

- For use with overhead cam heads
- 1° negative angle to prevent guide mushrooming • Pilots are slightly smaller than guide ID • 7.5" long

Guide ID /in	Driver OD	Pilot	Jobber	Order No.
4.0mm / .157"	9.0 / .355"	3.80 / .150"	\$22.79	PHL-2240-G
4.5mm / .177"	9.0 / .355"	4.30 / .170"	22.79	PHL-2245-G
5.0mm / .196"	9.0 / .355"	4.75 / .187"	22.79	PHL-2250-G
5.5mm / .217"	10.5 / .412"	5.21 / .205"	22.79	PHL-2255-G
6.0mm / .230"	9.1 / .358"	5.72 / .225"	22.79	PHL-2258-G
6.0mm / .236"	10.5 / .412"	5.72 / .225"	22.79	PHL-2260-G
6.6mm / .260"	11.8 / .463"	6.29 / .248"	22.79	PHL-2234-G
7.0mm / .275"	11.0 / .432"	6.60 / .260"	22.79	PHL-2235-G
7.9mm / .313"	10.7 / .423"	7.72 / .304"	22.79	PHL-2228-G
8.0mm / .315"	11.7 / .462"	7.80 / .307"	22.79	PHL-2236-G
8.7mm / .343"	12.4 / .487"	8.56 / .337"	22.79	PHL-2229-G
9.5mm / .375"	12.4 / .487"	9.32 / .367"	22.79	PHL-2231-G



Air-Powered Valve Guide Drivers for Diesel Engines

- Drive guides in from the shoulder instead of from the top
- Installing drivers have the proper recess to drive guides in for the correct installed height • Remove and install guides faster – no measuring necessary • For most standard pneumatic tools

Application	Installer Major/ Counter Bore ID	Order No.	Remover Shank/Pilot OD	Order No.
Cummins	.752" / .503"	DVG-Ci	.595" / .450"	DVG-CR
Cummins 8.3 6CT	.552" / —	DVG-8.3	.491" / .304"	DVG-71R
Caterpillar 3116	.515" / .475"	DVG-3116	.491" / .304"	DVG-71R
Caterpillar 3126	.633" / .506"	DVG-3126	.595" / .354"	DVG-3468R
Caterpillar 3306	.660" / —	DVG-3306	.595" / .354"	DVG-3468R
Caterpillar 3406-3408	.709" / —	DVG-3468i	.595" / .354"	DVG-3468R
Caterpillar 3406-3408B	.709" / —	DVG-3468Bi	.595" / .354"	DVG-3468R
Detroit GMC 53	.502" / .421"	DVG-53i	.491" / .246"	DVG-53R
Detroit GMC 71/92	.502" / .435"	DVG-71i	.491" / .304"	DVG-71R
International DT 466	.640" / .440"	DVG-466i	.595" / .354"	DVG-3468R
Mack	.675" / —	DVG-Mi	.620" / .484"	DVG-MR
Mack 4	.689" / .678"	DVG-M4	.595" / .354"	DVG-3468R

Jobber \$49.79 Jobber \$23.79

Air Hammer

Prevents valve guide damage

- Heavy-duty driver delivers 3500 blows per minute • Weighs 3 lbs. • .401" tool opening

Description	Jobber	Order No.
Air Hammer	\$74.99	AH-335
Replacement Retainer Spring	8.99	AH-5RS

Press Fit Lube

- Ideal for valve guides, piston pins, cylinder sleeves, etc.
- Eliminates the scoring, gouging and galling of parts during press fitting
- 6 oz. (177.4mL) Aerosol
- Order No. PFL-200
Jobber \$11.79

Buy 12 or more and SAVE 10% off jobber!



CYLINDER HEAD REBUILDING

CLEANING, ASSEMBLY & SAFETY

SHORT BLOCK REBUILDING

CRANKSHAFT/ FLYWHEEL GRINDING

BRAKE & ALIGNMENT TOOLS

MEASURING TOOLS

OFFROAD BIKE, ATV HARD PARTS

V-TWIN

Valve Guide Replacement

Adjustable Powered Valve Guide Driver With Replaceable Pilots

- Standardize the correct installed height on one guide then repeat it on all others
- Screw-in pilots with 5/16" - 18 threads
- 6 1/2" overall length

Description	Jobber	Order No.	Includes	
Standard Valve Guide Driver Kit	\$99.99	AVG-STD	▼	
Metric Valve Guide Driver Kit	99.99	AVG-MM	▼	
Pneumatic Body Only 5/8"-18 thread	49.99	AVG-1	x	x
Installation Sleeve	23.29	AVG-3	x	x
Locking Nut	8.79	AVG-2	x	x
Replaceable Pilots	Diameter			
	.312"	\$20.79	AVG-312	x
	.343"	20.79	AVG-343	x
	.372"	20.79	AVG-372	x
	.437"	20.79	AVG-437	x
	5.0mm	20.79	AVG-5MM	x
	5.5mm	20.79	AVG-55MM	
	6.0mm	20.79	AVG-6MM	x
	6.6mm	20.79	AVG-66MM	
	7.0mm	20.79	AVG-7MM	x
	8.0mm	20.79	AVG-8MM	x
	9.0mm	20.79	AVG-9MM	
Harley-Davidson® Adaptor (see right)	49.99	AVG-HD-KIT		



Pneumatic Driver Body (AVG-1)

Locking Nut (AVG-2) and installation sleeve have flats for positive lock and release adjustment

Powered Guide Driver Adaptor for Harley Heads

Adaptor Kit replaces standard screw-in pilot with longer "Harley" pilot. Cap then fits over the top of the guide to drive on the shoulder. Eliminates guide mushrooming. Order No. AVG-HD-KIT Jobber \$49.99

Adjustable installation sleeve (AVG-3) adjusts from 0" to 1/4" guide height and fits guides to .700" OD

Replaceable and interchangeable pilot (available in a variety of sizes, see chart at left). Use thread locker on pilot to resist loosening while in use

Exclusive

Due to the nature of this tool, it cannot be warranted against breakage, but it is guaranteed to be dimensionally correct

The more you buy, the more you save!

Buy 50 - 100 guides, save 10% off jobber.
Buy 100+ guides, save 20% off jobber
(mix & match sizes)



Cast Iron Valve Guides

Universal Applications

ID	OD	Length	Jobber	Order No.
.312"	.439"	2.281"	\$2.99	CIG-312
.342"	.502"	3.062"	2.99	CIG-342
.372"	.502"	2.750"	2.99	CIG-372
.343"	.564"	2.750"	2.99	OG-343
.373"	.564"	2.750"	2.99	OG-373

24 Valve 7mm Cummins Diesel (.511" seal surface) see tooling, page 22

ID	OD	Length	Jobber	Order No.
Intake	.275"	.502"	1.940"	\$3.29 CIG-3021
Exhaust	.275"	.502"	2.020"	2.99 CIG-3022

Ford 6.0L (.513" x 659" seal surface) see tooling, page 22

	.275"	.4395"	2.332"	\$2.99 CIG-3055
--	-------	--------	--------	-----------------

Manganese Bronze

Universal Applications

ID	OD	Length	Jobber	Order No.
.250"	.283"	1.250"	\$6.99	BVG-283-125
.250"	.310"	1.250"	4.99	BVG-310-125
.250"	.376"	1.250"	5.99	BVG-375-125
.311"	.439"	3.062"	4.49	BVG-311
.343"	.502"	2.375"	4.29	BVG-343
.372"	.502"	2.375"	4.29	BVG-372



The more you buy, the more you save!

Buy 10 or more and save 10% off jobber



Universal Repair Guides

- Unfinished ID ready to be reamed with AV&V's exclusive carbide reamers (p. 23) • Manganese bronze

ID	OD	Length	Jobber	Order No.
4.5mm	.620"	2.000"	\$7.49	UVBG-4.5MM
5.0mm	.620"	2.225"	7.49	UVBG-5MM
5.5mm	.620"	2.375"	7.49	UVBG-5.5MM
6.0mm	.620"	2.375"	7.49	UVBG-6MM
7.0mm	.740"	2.700"	8.99	UVBG-7MM
.308"	.740"	2.700"	9.49	UVBG-308
.372"	.740"	2.700"	9.49	UVBG-372

Replacement Valve Guides for Metric And V-Twin Applications



Choose from a wide range of replacement guides for Harley-Davidson®, Honda, Kawasaki, Suzuki, Yamaha and more. Check out the selection online or go to page 127.

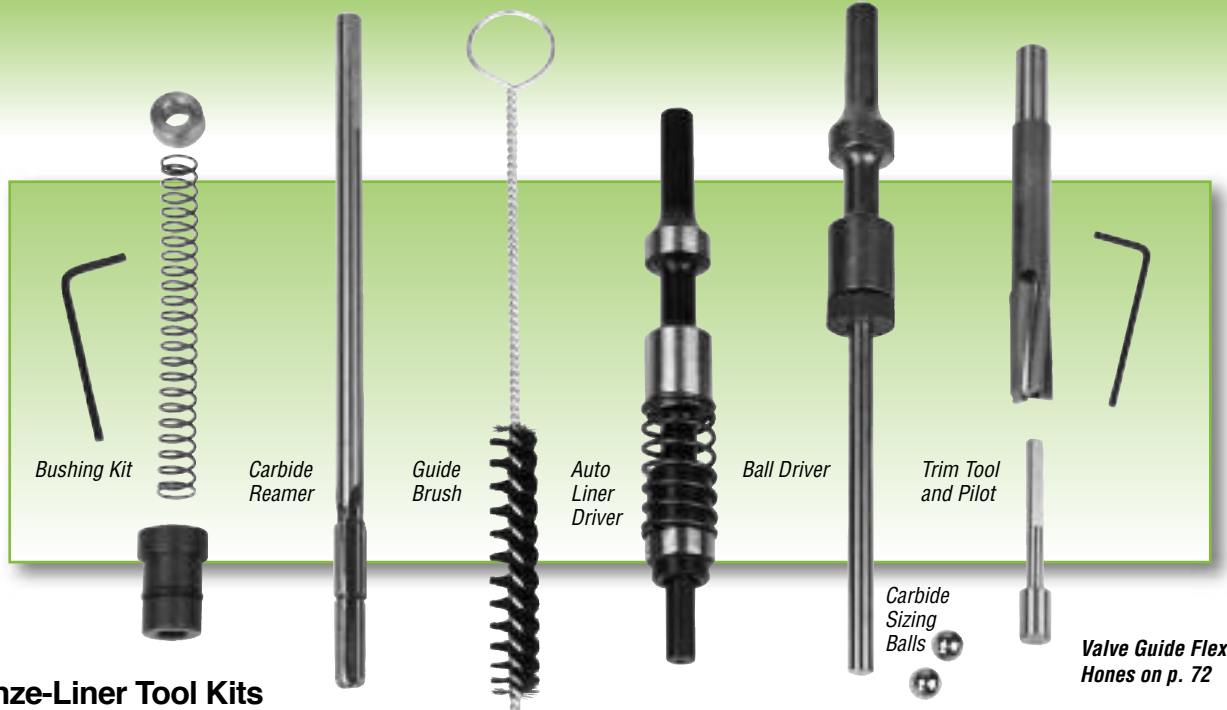

Bronze-Liner Tool Kits

Phosphor-Bronze is an ideal valve guide material – it's more durable than cast iron, conducts heat away faster and retains lubrication better to reduce wear. Install rugged, thin-wall (.030") Bronze-Liners in cast iron or aluminum heads to repair guides and deliver performance better than new! Plus, Bronze-Liners install quickly with simple tools. If a Bronze-Liner ever wears out, you can quickly and easily replace it with a new one to restore performance.

Kits include ▼	5.0mm Guides*		5.5mm Guides*		6.0mm Guides		6.6mm Guides		7.0mm Guides	
Master Tool Kits	\$549.99	CL-5MM	\$489.99	CL-5.5MM	\$399.99	CL-6MM	\$399.99	CL-6.6MM	\$399.99	CL-7MM
Carbide Reamer	154.99	CL-2028C	154.99	CL-2026C	127.29	CL-2024C	127.29	CL-2006C	127.29	CL-2007C
Bushing Kit	42.99	CL-2004	42.99	CL-2002	42.99	CL-2003	42.99	CL-2001	42.99	CL-2001
Ball Driver	82.99	CL-4454P	82.99	CL-4452P	82.99	CL-4452P	82.99	CL-4446P	82.99	CL-4446P
Carbide Sizing	24.99	.1965" CL-51965	24.99	.2175" CL-52175	24.99	.237" CL-5237	24.99	.261" CL-5261	24.99	.277" CL-5277
Balls	24.99	.197" CL-5197	24.99	.218" CL-5218	24.99	.238" CL-5238	24.99	.262" CL-5262	24.99	.278" CL-5278
Auto-Driver	114.99	CL-3610	114.99	CL-3600	114.99	CL-3600	114.99	CL-3566	114.99	CL-3507
Trim Tool	64.79	CL-5602	64.79	CL-5602	64.79	CL-5602	64.79	CL-5602	64.79	CL-5600
Trim Tool Pilot	22.99	CL-5636	22.99	CL-5634	22.99	CL-5634	22.99	CL-5626	22.99	CL-5626
Guide Brush	6.29	GVP-9N	6.29	GVP-10N	6.29	GVP-10N	6.29	GVP-10N	3.29	WCB-44

* 5.0mm and 5.5mm guides require our tooling, see page 29 for tech tip

Kits require Seat Centering Cones - see chart below

Kits include ▼	5/16" Guides		8.0mm Guides		11/32" Guides		9.0mm Guides		3/8" Guides	
Master Tool Kits	\$399.99	CL-312	\$399.99	CL-8MM	\$399.99	CL-343	\$499.99	CL-9MM	\$399.99	CL-375
Carbide Reamer	127.29	CL-2005C	127.29	CL-2008C	127.29	CL-2012C	127.29	CL-2018C	127.29	CL-2014C
Bushing Kit	42.99	CL-2000	42.99	CL-2000	42.99	CL-2000	42.99	CL-2000	42.99	CL-2000
Ball Driver	82.99	CL-4444P	82.99	CL-4444P	82.99	CL-4444P	82.99	CL-4444P	82.99	CL-4444P
Carbide Sizing	24.99	.3125" CL-53125	24.99	.316" CL-5316	24.99	.344" CL-5344	24.99	.355" CL-5355	24.99	.375" CL-5375
Balls	24.99	.313" CL-5313	24.99	.317" CL-5317	24.99	.3445" CL-53445	24.99	.356" CL-5356	24.99	.376" CL-5376
Auto-Driver	114.99	CL-3500	114.99	CL-3500	114.99	CL-3504	114.99	CL-3512	114.99	CL-3506
Trim Tool	64.79	CL-5600	64.79	CL-5600	64.79	CL-5600	64.79	CL-5600	64.79	CL-5600
Trim Tool Pilot	22.99	CL-5620	22.99	CL-5620	22.99	CL-5622	22.99	CL-5630	22.99	CL-5624
Guide Brush	3.29	WCB-44	3.29	WCB-44	3.29	WCB-44	3.29	WCB-44	3.29	WCB-44

60° Seat Centering Cones

- Center firmly in the valve seat • Cones feature a .625" ID
- Use the Seat Centering Cones with the Master Tool Kits (above) for proper alignment of the reamer and guide bore



Description	Jobber	Order No.
6 pc. Kit	\$194.99	CL-6500 ▼
Max. Dia.		
1" (25.4mm)	\$37.99	CL-6310 x
1 1/4" (31.7mm)	37.99	CL-6308 x
1 1/2" (38.10mm)	37.99	CL-6306 x
1 3/4" (44.45mm)	37.99	CL-6304 x
2" (50.80mm)	37.99	CL-6302 x
2 1/4" (57.15mm)	37.99	CL-6300 x
2 1/2" (63.5mm)	37.99	CL-6312

Chamfer Tool & T-Wrench

Use these optional accessories to remove any burrs that may be created when trimming the liner to length



Description	Jobber	Order No.
Chamfer Tool	\$19.99	CL-5800
T-Wrench	20.99	CL-5870

Valve Guide Liners & Tooling

Buy 3 or more sizing balls (any combination) and save 10% off jobber



Carbide Sizing Balls

- Finished to .0008" roundness
- Within the 90 Rockwell range
- The finished ID of the Bronze-Liner will be .001" smaller than the ball used



Size	Order No.	Size	Order No.
5.0mm	.196" CL-5196	8.0mm .315" CL-5315	
	.1965" CL-51965	.316" CL-5316	
	.197" CL-5197	.317" CL-5317	
5.5mm	.2165" CL-52165	8.02mm .318" CL-5318	
	.2175" CL-52175	.319" CL-5319	
	.218" CL-5218	1 1/32" .343" CL-5343	
	.218" CL-5218	.3435" CL-53435	
6.0mm	.236" CL-5236	.344" CL-5344	
	.237" CL-5237	.3445" CL-53445	
	.238" CL-5238	.345" CL-5345	
	.238" CL-5238	.346" CL-5346	
6.6mm	.260" CL-5260	3/8" .373" CL-5373	
	.261" CL-5261	.374" CL-5374	
	.262" CL-5262	.3745" CL-53745	
7.0mm	.276" CL-5276	.375" CL-5375	
	.277" CL-5277	.3755" CL-53755	
	.278" CL-5278	.376" CL-5376	
5/16"	.312" CL-5312	9.0mm .354" CL-5354	
	.3125" CL-53125	.355" CL-5355	
	.313" CL-5313	.356" CL-5356	
	.314" CL-5314		

Jobber \$24.99

Phosphor-Bronze liners outlast original guides and are easy to replace

Stripe helps you quickly identify the round nose end
Rounded nose design makes installation fast and easy

Thin-Wall .030" Bronze-Liners

- Outlast original guides
 - Cross-hatch promotes oil retention
 - Rounded nose design makes installation quick and easy
 - Stripe helps you identify rounded end
 - Phosphor-bronze
- NOTE: 5.0 & 5.5mm Guides do NOT interchange with our competitors' guides. You MUST use our tooling with these guides**

Guide Size	Liner Size		Box of 16	Box of 100
	OD	Length	Order No.	Order No.
5.0mm	+0.030"	2.50"	CL-500	CL-500A
5.5mm	+0.030"	2.50"	CL-550	CL-550A
6.0mm	+0.030"	2.50"	CL-600	CL-600A
6.6mm	+0.030"	2.50"	CL-660	CL-660A
7.0mm	+0.030"	2.50"	CL-700	CL-700A
.312"	+0.030"	2.50"	CL-1220	CL-1220A
8.0mm	+0.030"	2.50"	CL-1420	CL-1420A
.343"	+0.030"	3.00"	CL-1640	CL-1640A
.343" +.002"	+0.032"	3.00"	CL-1640-2	CL-1640-2A
9.0mm	+0.030"	2.50"	CL-1690	CL-1690A
.375"	+0.030"	3.00"	CL-1830	CL-1830A
.375" +.002"	+0.032"	3.00"	CL-1820-2	CL-1820-2A

Jobber \$18.99 \$81.99

Removal Tool

Remove bronze liners without damaging the bore

Description	Jobber	Order No.
5.0mm	\$43.99	CL-7356
5.5mm	43.99	CL-7354
6.0mm	43.99	CL-7352
6.6mm	43.99	CL-7342
7.0mm	43.99	CL-7344
5/16"	43.99	CL-7310
8.0mm	43.99	CL-7320
11/32"	43.99	CL-7330
9.0mm	43.99	CL-7348
3/8"	43.99	CL-7340

Universal Driver Tool

Fits all removal tools at left and is designed to work with your air hammer
Order No. **CL-7333**
Jobber \$35.29



Tungsten Carbide Ball Broaches Give You The Accuracy of Carbide Balls With The Ease of Broaching Tools

- Finished liner ID will be .001" smaller than the ball used
- Other sizes available

Guide ID	Ball Size	Order No.
11/32"	.3430" 8.71mm	RBB-3430
	.3440" 8.74mm	RBB-3440
	.3445" 8.75mm	RBB-3445

Jobber \$67.99

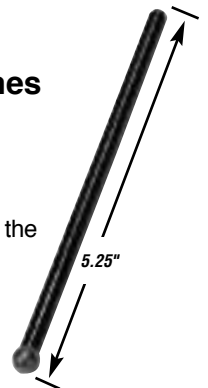

Small Hole Gauge Set

- See if rebuilding or replacing is needed by checking actual guide wear
- Check guide bosses for proper interference fit during replacement
- Check and maintain correct stem-to-guide ID clearance
- 4-piece set has combined range of .125" to .500"
- With storage case
- Order No. **SHG-5** Jobber \$134.79



.015" Oversize Valve Guide Drill-Reamer

- Reams guide ID .015" larger for an oversized valve stem
- Use by hand or in a seat & guide machine

Dia.	Finish Size	Jobber	Order No.
5/16"	.327"	\$79.99	OVR-312015
11/32"	.358"	79.99	OVR-343015
3/8"	.390"	79.99	OVR-373015



Bronze bushings thread easily into tapped bores. Replace guides at any time by simply uncoiling the old ones.



Bronze-Wall® Bushings

- Spiral inserts rebuild cast-iron guides worn to .030"
- Highly durable Phosphor-Bronze
- Thread easily into tapped bore
- Helps guides and stems last longer
- .038" wire for reamed guides

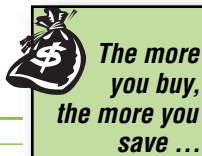

The more you buy, the more you save ...

3-5 boxes of bushings, save 10% off jobber, 6 or more boxes, save 20% off jobber

Size	Qty.	Jobber	Order No.
Standard Bushings			
5/16"	50	\$66.99	BW-010B-G
1 1/32"	50	66.99	BW-020B-G
3/8"	50	66.99	BW-050B-G
Reducing Bushings			
1 1/32" to 5/16"	50	\$114.99	BW-2010B-G
3/8" to 1 1/32"	50	114.99	BW-5020B-G

Bronze-Wall® Tooling

Description	ID Size	Jobber	Order No.	Includes	
Tool Sets	5/16"	\$349.99	BWS-61-G	▼	
bushings sold	1 1/32"	349.99	BWS-62-G	▼	
separately	3/8"	349.99	BWS-63-G	▼	
Tap Tool	5/16"	119.99	BW-601-G	x	
	1 1/32"	119.99	BW-621-G	x	
	3/8"	147.99	BW-641-G	x	
Insert Tool	5/16"	77.29	BW-603-G	x	
	1 1/32"	77.29	BW-623-G	x	
	3/8"	77.29	BW-643-G	x	
Broach	5/16"	45.49	BW-606-G	x	
	1 1/32"	45.49	BW-626-G	x	
	3/8"	45.49	BW-646-G	x	
Reamer*	5/16"	.3125"	99.99	BW-602-G	x
left-hand	1 1/32"	.3407"	99.99	BW-622-3-G	
rotation		.3417"	99.99	BW-622-2-G	
		.3427"	99.99	BW-622-1-G	
*other sizes may be substituted at no extra charge		.3437"	99.99	BW-622-G	x
		.345"	99.99	BW-622A-G	
	3/8"	.3725"	99.99	BW-682-G	
		.374"	109.99	BW-642-1-G	
		.375"	99.99	BW-642-G	x
Cut-Off Tool	5/16"	64.99	BW-471-G	x	
	1 1/32"	64.99	BW-473-G	x	
	3/8"	64.99	BW-476-G	x	

Accessories	Jobber	Order No.
1/4" Tap/Drive Adaptor for 1/2" Drill	\$41.29	BW-442-G
Retainer Clamp Driver	14.29	BW-381-G
Bushing Retainer Clamp	4.49	BW-382-G
5/16" - 1 1/32" Bushing Retainer	11.49	BW-386-G
3/8" - 7/16" Bushing Retainer	11.49	BW-388-G
1 1/32" to 5/16" Reducing Bushing Insert Tool	59.79	BW-603P-G
3/8" to 1 1/32" Reducing Bushing Insert Tool	59.79	BW-623P-G
Valve Guide Cleaning Brush	3.29	WCB-44

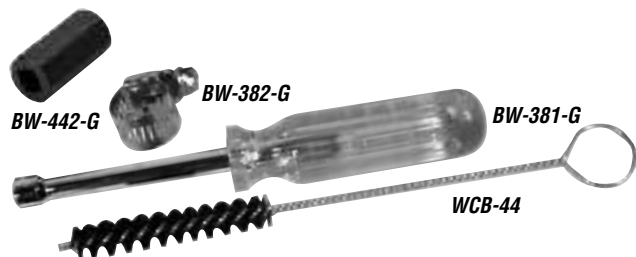

Bronze-Wall® 2 Bushings

- Spiral inserts rebuild cast-iron guides worn to .030"
- Highly durable Phosphor-Bronze
- Thread easily into tapped bore
- Helps guides and stems last longer
- .035" wire for broached guides
- Easy to install and size using Sizing Ball and Driver instead of Broach and Reamer

Size	Qty.	Jobber	Order No.
Standard Bushings			
5/16"	50	\$63.99	BW2B-312
1 1/32"	50	63.99	BW2B-343
3/8"	50	63.99	BW2B-375

Bronze-Wall 2® Tooling

Description	ID Size	Jobber	Order No.	Includes	
Tool Sets	5/16"	\$349.99	BW2-312-SET	▼	
bushings sold	1 1/32"	349.99	BW2-343-SET	▼	
separately	3/8"	349.99	BW2-375-SET	▼	
Tap Tool	5/16"	119.99	BW-601-G	x	
	1 1/32"	119.99	BW-621-G	x	
	3/8"	147.99	BW-641-G	x	
Insert Tool	5/16"	77.29	BW-603-G	x	
	1 1/32"	77.29	BW-623-G	x	
	3/8"	77.29	BW-643-G	x	
Ball Driver	Universal	82.99	CL-4444P	x x x	
Sizing Balls	5/16"	.312"	24.99	CL-5312	x
more on	1 1/32"	.343"	24.99	CL-5343	x
page 39	3/8"	.373"	24.99	CL-5373	
		.374"	24.99	CL-5374	x
Cut-Off Tool	5/16"	64.99	BW-471-G	x	
	1 1/32"	64.99	BW-473-G	x	
	3/8"	64.99	BW-476-G	x	

Accessories	Jobber	Order No.
1/4" Tap/Drive Adaptor for 1/2" Drill	\$41.29	BW-442-G
Universal Drive Adaptor	35.29	CL-7333
Valve Guide Cleaning Brush	3.29	WCB-44

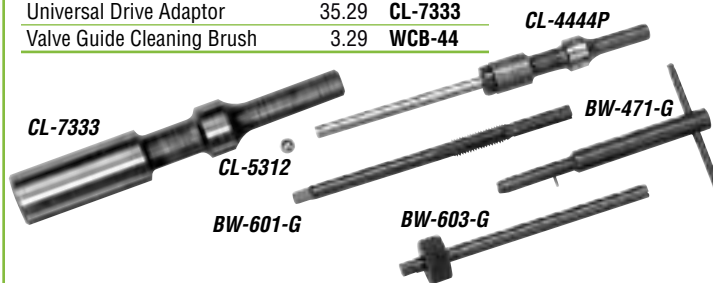

Bronze Reaming Oil

- Prevents build-up • Extends reamer life
- Improves valve guide finish

Size	Jobber	Order No.
1 pint/473.2 mL	\$ 9.99	BW-303-G
1 quart/946.6 mL	15.99	BW-303A-G
1 gallon/ 3.79 L	35.99	BW-305-G



Valve Guide Knurling

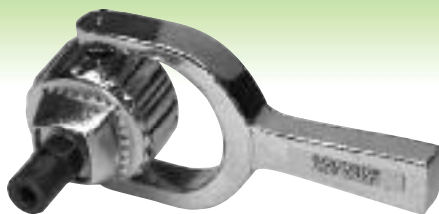

Speed Reducer Reduces the RPM Of Your Electric Drill By 80%

- Increases power and control for better reaming and knurling
- Square drive
- For reamers .281" or larger, adaptors available for smaller reamers (sold separately)

Description	Jobber	Order No.
Speed Reducer with Handle	\$129.99	WSR-41A-HD
1/4" Adaptor (for arbors/reamers larger than .281") (Use with WSR-41-7-G)	10.99	WSR-41-3-G
3/16" Adaptor (for arbors/reamers .281" or smaller) (Use with WSR-41-7-G)	14.99	WSR-41-4-G
Drill End Drive Adaptor (for 3/8" drill)	7.99	WSR-41-7-G
Snap On Adaptor (converts WSR-41-3-G from .250" to .1875")	24.99	WSR-41-5-G



Knurling Arbors

- Piloted for positive centering
- Use by hand or with electric drill & speed reducer
- **Not for use on chilled, hardened or bronze guides**

Inch	mm	Jobber	Order No.
.236"	6.00	\$89.99	WKA-6MM-G
.275"	7.00	89.99	WKA-7MM-G
.312"	7.92	89.99	WKA-312-G
.343"	8.71	89.99	WKA-343-G
.375"	9.53	89.99	WKA-375-G
.437"	11.10	99.99	WKA-437-G
1 Quart Knurlube (946.6mL)		13.99	WLB-47-G

NOTE: We don't stock knurling arbors smaller than 6mm because smaller guides are chilled and these arbors may fail.



Use with Knurlube



Knurling is best for integral valve guides but remember knurling will not correct extreme wear. The knurling arbor creates a "thread" in the guide as it deforms the metal making the inside diameter of the guide smaller. Note that the thread is formed, not cut. Goodson recommends knurling only be used on softer guides such as cast iron. Chilled, hardened and bronze guides may damage the knurling tools.

Knurlube

- High pressure lube
- Prevents tool damage
- Extends knurler life by reducing friction and arbor wear

Size	Jobber	Order No.
1/2 Pint	\$ 8.99	WLB-46-G
236.6mL		
1 Quart	13.99	WLB-47-G
946.6mL		

Spiramp® Patented, One-Step Guide Resizing tool

- Raises the guide material
- Restores the original ID better than knurling / reaming

Note: Spiramp® is NOT for chilled or hardened guides

Arbor Size	Burnisher Size	Jobber	Order No.
5/16" Arbor	.312" Burnisher	\$109.79	SR-312
11/32" Arbor	.343" Burnisher	109.79	SR-343
3/8" Arbor	.373" Burnisher	109.99	SR-373
Knurlube	1 Quart	13.99	WLB-47-G

Note: Use Knurlube when resizing guides to lessen friction and prevent damage to Spiramp® tooling



Valve Guide OD Knurling Tool

- Enlarge guide to fit bore
- Ideal for rare metric sizes and aluminum heads with damaged guide bores
- Works on all materials, **except** chilled or hardened guides

Description	Jobber	Order No.
Complete Tool	\$64.99	VGK-25
Knurling Wheel	23.99	VGK-25W
Knurling Rollers (2)	9.99	VGK-25R



Directions for use: Hold guide firmly in vise, drill press or Seat & Guide machine; tighten the knurler and turn it around the guide by hand. Increase OD up to .002"



1" Diameter Carbide Top Cutter / Spot Facer

- Long-life, quick-cutting carbide blades
- Shorten or face cast-iron valve guides and stud bosses up to 1" / 25.4mm diameter
- Universal drive shank fits all types of power chucks

Description	Jobber	Order No.
Cutter Body (.375" Dia. Shank)	\$82.99	G-1270
Pilot .312" / 7.93mm	14.99	G-1270A
.343" / 8.73mm	14.99	G-1270B
.375" / 9.53mm	14.99	G-1270C
.437" / 11.11mm	14.99	G-1270D

Pilot Installs Here

Cutter Body



Pilot

Carbide or High Speed Steel Valve Guide Top Cutters

- Matches Seat & Guide machine pilots

Description	Shank	Jobber	Order No.
Cutters 1 1/16" High-Speed Steel	.500"	\$52.49	GFH-100
1 1/8" High-Speed Steel	.486"	89.79	GFH-300
1 1/16" Carbide	.500"	139.49	GFC-200
Shank Pilots 3/16" (.1875")	.312" / 7.93mm	18.79	GFP-312
.343" / 8.73mm	18.79	GFP-343	
.375" / 9.53mm	18.79	GFP-375	
.437" / 11.11mm	18.79	GFP-437	
.500" / 12.70mm	18.79	GFP-500	

3/16" dia. shank

Cutter

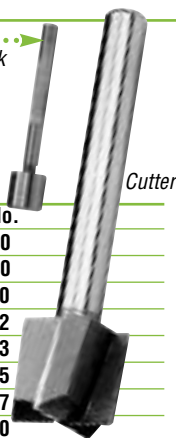

Full Service ... FAST!



"Our goal is to get your order to you as fast and accurately as possible. In fact, we ship your product as fast as possible at the lowest cost to you."

- Richard, Goodson Shipping Manager, 13 yrs. of service

CYLINDER HEAD
REBUILDING

CLEANING,
ASSEMBLY & SAFETY

SHORT BLOCK
REBUILDING

CRANKSHAFT/
FLYWHEEL GRINDING

BRAKE & ALIGNMENT
TOOLS

MEASURING
TOOLS

OFFROAD BIKE, ATV
HARD PARTS

V-TWIN
HARD PARTS

Valve Seal Puller Kit

- Removes jacketed valve stem seals effortlessly
- Hardened diameter-adjustable removal pins bite into seal jacket
- Slide hammer assembly removes seals effortlessly
- Fits bucket bores as small as 1.080" / 27.43mm

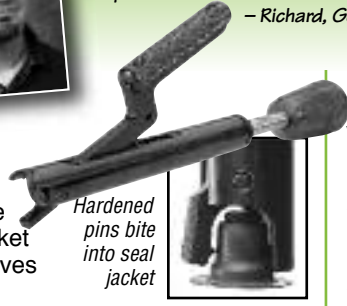

Hardened pins bite into seal jacket

Description	Jobber	Order No.	Incl.
Valve Seal Puller Kit	\$149.99	VSP-75	▼
Replacement Set Screws	.250" / 6.35mm 2.99	VSP-78	x
	.312" / 7.92mm 2.99	VSP-76	x
	.375" / 9.53mm 2.99	VSP-77	x
Replacement O-Ring	2.99	VSP-79	x

Valve Seal Puller Fits Multi-Valve Engines

- Lifts from the bottom of the seal • Works within the confines of lifter bucket bores • Four fingers grip seal for fast and easy removal • .810" tool dia.
- Works on most domestic and import vehicles including Audi & VW 5 valve

Description	Jobber	Order No.
Valve Seal Puller	\$179.99	VSP-320
Replacement Jaw Set	72.79	VSP-JAWS
Replacement Sleeve	37.99	VSP-SLEEVE
Replacement Shaft	32.99	VSP-320-SHAFT
Replacement O-Ring	3.99	VSP-O-RING

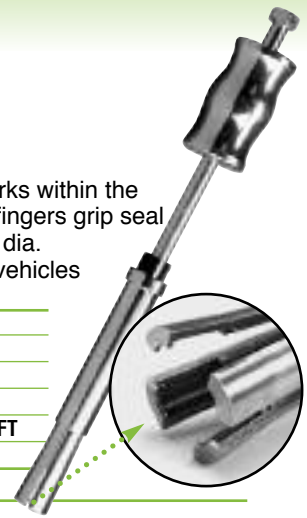

Universal Seal Pliers

- Works on OHC and in-line engines with recessed springs
- Removes Teflon seals • Long, serrated jaws reach into confined areas and grip seals firmly
- Heat-treated steel with easy grip handles
- Order No. **VSP-823**
Jobber \$49.99



Valve Stem Seal Puller

- Plier handles rotate to any position above the head while the jaw assembly goes into the spring cavity
- Can be used straight or at any angle up to 90°
- Jaw tip includes thin ledge for "hooking" underneath stubborn valve stem seals • 4 vertical raised ridges on inner jaw diameter help grip the outside diameter of the seal
- Order No. **VSP-629** Jobber \$84.99

Teflon Seal Setters

- Coaxial aluminum driver with handle
- Won't damage the seal



Teflon Seal Installers		Replacement Sleeve		
Stem Size	Jobber	Order No.	Jobber	Order No.
.312"	\$49.99	TSI-312	\$28.99	TSIB-312
8mm	49.99	TSI-8MM	28.99	TSIB-8MM
.343"	49.99	TSI-343	28.99	TSIB-343
.375"	49.99	TSI-375	28.99	TSIB-375

Premium Viton Positive Seals and Valve Seal Cutter for Chevy Vortec 5.7L Heads

Now install aftermarket high lift camshafts without spring to seal interference. The Vortec engine is prized for its ability to create horsepower right out of the box. But to squeeze additional horsepower out of the engine you'll need to do a little machining. This new Valve Seal Cutter is designed specifically for the Chevy Vortec head. It cuts the guide height and chamfers the outside diameter of the valve guide all at the same time. The smaller seals will let you install aftermarket high lift camshafts without seal damage from interference contact. For spring seats, use our **VSS-1320** Spring Seat Cutter.



Conversion Calculator

We've tried to convert as many SAE measurements to Metric (and vice versa) as possible. In some cases there just hasn't been enough room. If you need to convert a measurement, here are the formulas:

Starting Measurement	Conversion Formula	Converted Measurement
Inches (in)	# Inches x 25.4	Millimeters (mm)
Feet (ft)	# Feet x .0348	Meters (m)
Millimeters (mm)	# Millimeters ÷ 25.4	Inches (in)
Fahrenheit (F)	(5-9) x (F-32)	Celsius (C)
Celsius (C)	(9-5) x C + 32	Fahrenheit (F)

Description	Jobber	Order No.
Vortec Seal Cutter	\$64.99	VSC-495
Hardened & Ground Pilot - 1 1/32" (8.7mm)	19.99	VP-343
.495" ID Vortec Metal Seals (16 pack)	28.99	VVS-495
Spring Seat Cutter for Vortec Heads	74.99	VSS-1320

Valve Stem Oil Seals

Valve Stem Oil Seals

- Better oil regulation than umbrella-type • Seals mount firmly on guide & wipe valve stem clean of excess oil • Sized precisely for proper lubrication
- 32 per box (VVS-495 is 16 per box)

NOTE: Seals marked with * are high-temperature exhaust seals • Valve Seal Cutters on page 25

Buy 3 or more boxes of seals (mix & match) and take an extra 10% off jobber

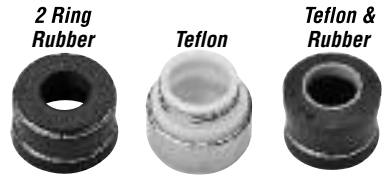

Seals enlarged to show detail

2-Ring Rubber					
Guide OD	Stem OD	Cutter & Pilot Needed	Jobber	Order No.	
.562"	.341"	(VSC-562343)	\$46.99	3011F*	
.562"	.341"	(VSC-562343)	33.99	3011D	
.625"	.372"	(VSC-625375)	24.99	3012	
High Temperature Resistant Viton					
Guide OD	Stem OD	Cutter & Pilot Needed	Jobber	Order No.	
.495"	.341"	(VSC-495343)	\$28.99	VVS-495	
.531"	.341"	(VSC-531343)	33.99	3711F*	

Teflon					
Guide OD	Stem OD	Cutter & Pilot Needed	Jobber	Order No.	
.415"	.311"	(VSC-415312)	\$42.99	5910	
.500"	.341"	(VSC-500343)	36.99	5611	
.500"	.372"	(VSC-500375)	39.99	5612	
.531"	.311"	(VSC-530312)	29.99	5710	
.531"	.341"	(VSC-530343)	52.99	5711	
.531"	.372"	(VSC-530375)	53.99	5712	

Teflon and Rubber					
Guide OD	Stem OD	Cutter & Pilot Needed	Jobber	Order No.	
.500"	.311"	(VSC-500312)	\$28.99	4610	
.500"	.341"	(VSC-500343)	44.99	4611	
.500"	.372"	(VSC-500375)	30.99	4612	
.531"	.341"	(VSC-530343)	32.99	4711	
.562"	.341"	(VSC-562343)	39.99	4811	
.625"	.372"	(VSC-625375)	36.99	4012	

Universal! Fits all 1 1/32" Valve Stems

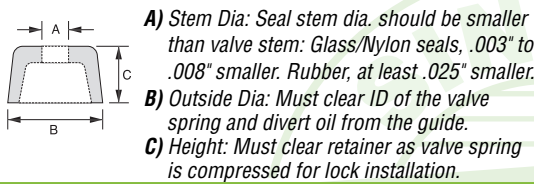
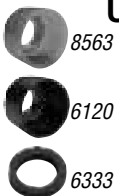

Type	QTY.	(A)	(B)	(C)	Jobber	Order No.
High Temp: Glass/Nylon Umbrella	32	.335"	.715"	.455"	\$7.99	8563
Low Temp: Rubber Umbrella	32	.310"	.755"	.560"	7.99	6120
Low Temp: Rubber O-Ring	100				5.99	6333

Cummins Diesel Valve Seals



For Intake & Exhaust

- For 24 valve, 7mm Cummins Diesel Engines

Application	Stem Size	OD	Qty.	Jobber	Order No.
Intake	7.0mm	.511"	12	\$16.99	CVS-59i
Exhaust	7.0mm	.511"	12	16.99	CVS-59E



OE Style Valve Seals

Application	Guide OD	Stem Dia.	Qty.	Jobber	Order No.
Evo/Twin Cam	.420"	.312"	20	\$21.99	HSS-420
Evo/Iron Head Sportster (Intake)	.530"	.312"	20	21.99	HSS-530312
Iron Head Sportster (Exhaust)	.530"	.341"	20	21.99	HSS-530341
Pan/Shovel Head (1948-79)	.562"	.375"	20	21.99	HSS-562
Shovel Head (1980-84)	.625"	.375"	20	21.99	HSS-625



Viton Valve Seals

- Resist temperatures up to 50° higher than other viton seals

Size	Application	Guide OD	Stem Dia.	Qty.	Jobber	Order No.
6mm	V-Rod	8.5mm	6mm	20	\$18.99	HVS-6MM
7mm	Double Spring	.562"	7.0mm	20	29.99	HV-7MM
7mm	OE Replacement	.562"	7.0mm	20	29.99	HV-7MMOE
.420"	Evo / Twin Cam	.421"	.3125"	20	18.99	HVS-421
.530"	Evo / Twin Cam	.531"	.3125"	20	19.99	HVS-531

AV&V Viton Valve Seals

- Made from a special Viton compound, these seals can resist higher temperatures than regular Viton seals
- 10 per pack

Application	Guide OD	Stem Dia.	Order No.
Honda			
CRF 150R Intake & Exhaust (07-08)	.325"	4.5mm	MV-039-10
CRF 250R Intake & Exhaust (04-07)	.339"	5.0mm	MV-023-10
TRX400EX Intake & Exhaust (99-07)			
TRX/CRF 450R Intake (02-08)	.360"	5.5mm	MV-091-10
TRX/CRF 450R Exhaust (06-09)			
TRX/CRF 450R Exhaust (04-05)	.339"	5mm	MV-098-10
Yamaha			
YFZ 450 Intake & Exhaust (03-09)	.325"	4.5mm	MV-039-10
Suzuki			
LTR-450 Intake & Exhaust (06-09)	.360"	5.5mm	MV-091-10
Can Am			
DS 450 Intake & Exhaust (08)	.4360"	6mm	MV-047-10
Kawasaki			
KX 250F Intake (03-09)	.293"	4.5mm	MV-010-10
			Jobber \$12.99

CYLINDER HEAD REBUILDING
CLEANING, ASSEMBLY & SAFETY
SHORT BLOCK REBUILDING
FLYWHEEL GRINDING
CRANKSHAFT/ FLYWHEEL GRINDING
BRAKE & ALIGNMENT TOOLS
MEASURING TOOLS
OFFROAD BIKE, ATV HARD PARTS
V-TWIN HARD PARTS

From our customers:

"Thank you for the fast, friendly service. Being so prompt helped me keep my customers satisfied as well."

- Phillip Jaramillo, Bosque Farms, New Mexico

Slide Hammer:
A quick tap loosens keepers for fast removal

Exclusive

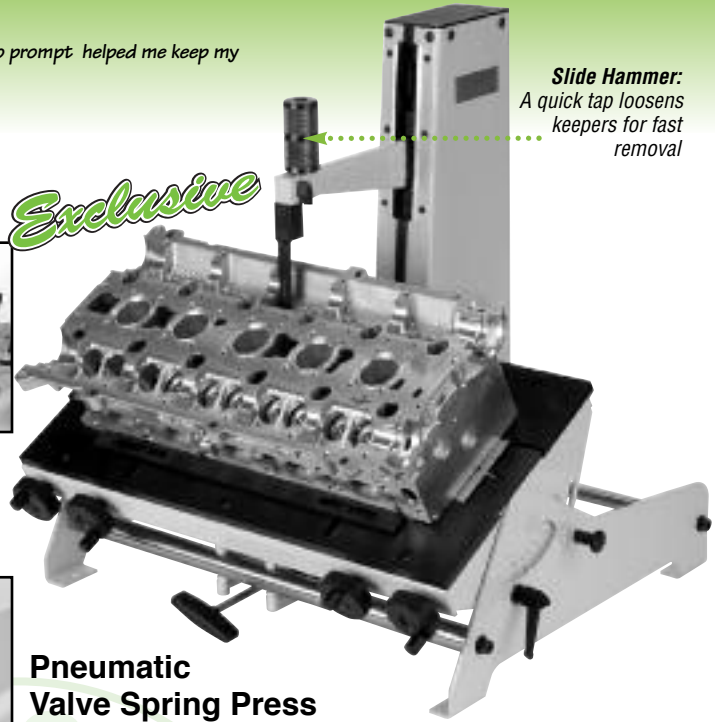

Pneumatic Valve Spring Press

- Pneumatic valve support holds valve closed as you compress the spring • Adjustable stainless steel plate won't damage the head
- 28mm Valve Spring Adaptor is standard with unit (other sizes are available, see chart on page 35)
- Ideal for use on heads with recessed springs
- For aluminum and cast iron heads
- Fully assembled • Measures 28"L x 24"W x 26"H
- Shipping weight: 143 lbs.
- Order No. **PSB-5000** Jobber \$5,339.99



Pneumatic Head:
Adjustable to 25° in either direction for canted valves



Head Support: Table adjusts 45° to the front and 30° to the rear



Positive Stops:
Adjusts front and rear angles



Speed Knobs: Allows quick positioning of workpiece



Foot Pedal: Easy, hands-free operation



Quick Release Knob: allows fast positioning to opposite cam bank

Keeper Tools on p. 36

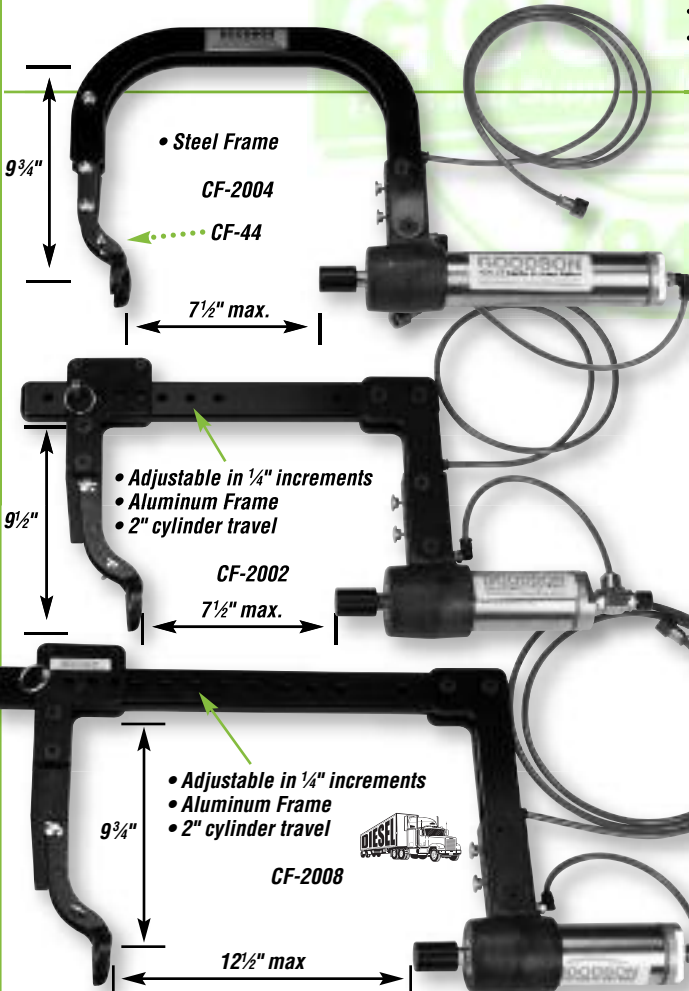

CF-2003
Retrofit Cylinder & Valve Assembly Kit
Fits most common pneumatic compressors including our CF-2004

GOODSON Pneumatic Valve Spring Compressors & Accessories

- Deliver 325 lbs. of force at 130 PSI
- Handle springs from 3/4" to 1 3/4" diameter
- Fingertip control • Replaceable jaws
- Full 1 year warranty

Description	Jobber	Order No.
Complete Valve Spring Compressor	\$369.99	CF-2004
Tech Tip Retrofit Cylinder & Valve Assembly Kit (retrofits most common pneumatic compressors)	259.99	CF-2003
Adjustable Automotive Valve Spring Compressor	459.99	CF-2002
Adjustable Diesel Valve Spring Compressor	514.99	CF-2008
Replacement Valve Spring Adaptor Jaw	13.99	CF-44
Replacement Valve Spring Adaptor Jaw - HD	19.99	CF-44HD
Replacement 1/4" Green Air Line (sold by lin. ft.)	1.99	CF-2001-AL
Replacement Air Control Needle Valve	42.99	CF-2001-NV
1/4" NPT L-Fitting	5.99	CF-2003-BCE
1/8" NPT L-Fitting	3.99	CF-2003-L
Retrofit Frame Extension	67.99	CF-2050
Recessed Spring Adaptors	21mm OD: 55.79 26mm OD: 55.79	CF-2010 CF-2032

Recessed Spring Adaptors



CYLINDER HEAD REBUILDING
CLEANING, ASSEMBLY & SAFETY
SHORT BLOCK REBUILDING
CRANKSHAFT/ FLYWHEEL GRINDING
BRAKE & ALIGNMENT TOOLS
MEASURING TOOLS
OFFROAD BIKE, ATV HARD PARTS
V-TWIN HARD PARTS

Valve Spring Compressors

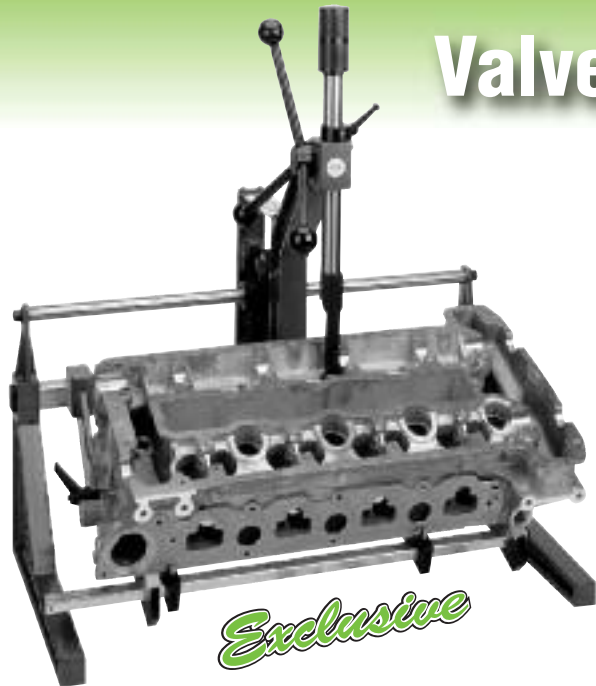

Exclusive

Speed Up Valve Spring Replacement With The Manual Valve Spring Bench

- Remove and install valve springs on heads with recessed springs
- 26"L x 22"W x 35"H footprint and weighs 31 lbs.
- Includes 28mm dia. spring adaptor
- Locking collar can be used to stop vertical travel or to keep the spring compressed while assembling keepers
- Frame tilts up to 25° in either direction for canted valves
- Full cylinder head support is adjustable from 0 to 45°
- Integral slide hammer easily releases stuck keepers
- Other spring adaptors also available (see chart below)
- Replacement parts available
- Order No. **CF-500** Jobber \$1,819.99

Keeper Tools on p. 36



Lock Collar: Can be used to stop vertical travel or to hold spring compressed while assembling keepers

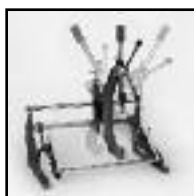

Adjustable Frame: Adjustable to 25° in either direction for canted valves



Locking Arm: Holds the C-frame securely in position at the desired angle



Head Support: Adjustable from 0-45° and locks in place



Dowel Pins: Keeps the workpiece in place at any head support angle



Slide Hammer: A quick tap releases keepers that are stuck in retainers

Spring Adaptors for Valve Spring Benches

- Fit both manual (**CF-500**) and pneumatic (**PSB-5000**) spring benches
- Nylon insert is replaceable



Description	Reach	Jobber	Adaptor	Jobber	Insert
18mm	4½"	\$259.99	CF-518	\$18.99	CF-518-1
23mm	4½"	259.99	CF-501	18.99	CF-501-1
28mm	3½"	259.99	CF-502	18.99	CF-502-1
35mm	2½"	259.99	CF-503		
Locking Collar				\$54.99	CF-500-230

Pneumatic Valve Spring Compressor Rebuild Kit

- For pneumatic spring compressors with threaded shaft such as Plews & Clark Feather
- Includes seals, valves, springs and o-rings
- Order No. **CF-700-RK** Jobber \$69.99

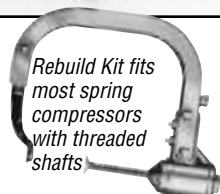

Rebuild Kit fits most spring compressors with threaded shafts



Original MTI®



Easy-to-use controls

Maximum 8.25" total clearance between the receiver and the adjusting screw.

CF-3000-LS1

On-the-Bench Pneumatic Spring Compressor

- Handles springs up to 1500 lbs. at 90 PSI!
- Standard heavy-duty jaw fits springs up to 1.600" diameter
- Optional jaw fits springs to 1.740" diameter
- Features a dual stage cylinder that produces more force each time the control is pressed
- **Guaranteed to a maximum of 90 psi/620.5 kPa pressure**

Description	Jobber	Order No
Hi-Perf. Spring Compressor with 1.600" ID Jaw	\$1299.99	CF-3000B
Replacement Standard Jaw, 1.600" ID	119.99	CF-3002
Adaptor Jaw, 1.740"/44.2mm ID	119.99	CF-3003
LS1 Series Jaw Adaptor	19.99	CF-3000-LS1
Rebuild Seal Kit (includes Intake Button Return Spring)	34.99	CF-3000SK
Replacement Intake Button Return Spring only	8.99	CF-3004

CYLINDER HEAD REBUILDING

CLEANING, ASSEMBLY & SAFETY

SHORT BLOCK REBUILDING

CRANKSHAFT/FLYWHEEL GRINDING

BRAKE & ALIGNMENT TOOLS

MEASURING TOOLS

OFFROAD BIKE, ATV HARD PARTS

V-TWIN HARD PARTS



"You'll always get fast, reliable service from Goodson, even on international orders. We'll do whatever it takes to make sure you get your shop supplies as quickly and easily as possible - anywhere in the world."
- Kim, Goodson Customer Service Manager, 29 yrs. of service

CYLINDER HEAD REBUILDING
CLEANING, ASSEMBLY & SAFETY
SHORT BLOCK REBUILDING
CRANKSHAFT/ FLYWHEEL GRINDING
BRAKE & ALIGNMENT TOOLS
MEASURING TOOLS
OFFROAD BIKE, ATV HARD PARTS
V-TWIN HARD PARTS



Manual Valve Spring Compressor

- Weighs only 6 lbs
- High leverage allows for easy, one-hand operation
- Covers a range from 10" high to 8" deep • Works with most valve-in-head and L-head engines • Fits truck and tractor engines
- Jaws adjust for small, medium and large springs

Description	Jobber	Order No.
Spring Compressor	\$89.99	CF-140
Jaw Set	13.99	CF-44
HD Replacement Jaw Set	19.99	CF-44HD



Manual Valve Spring Compressor For Small Engines

- Compress **only** the spring for fast and easy keeper removal • Fully adjustable steel jaws have maximum opening of 2 1/2"/63.5mm
- Fits springs from 1/2" / 12.7mm to 1 1/8" / 28.6mm dia. • Cadmium finished spring steel construction
- Order No. **CF-131** Jobber \$17.99

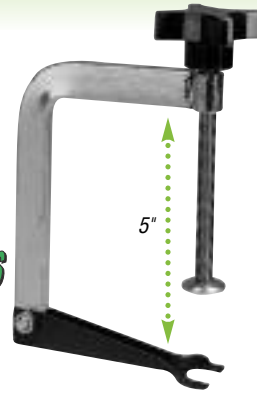

Manual Valve Spring Compressor For Small Engines

- Features an adjustable foot to fit retainers of many sizes • Once you lock the compressor in position, your hands are free to work • Includes 2 jaw sets - small (for springs up to 7/8"/22.2mm) and large (for springs up to 1 1/8"/27.0mm)
- Order No. **CF-600** Jobber \$21.99

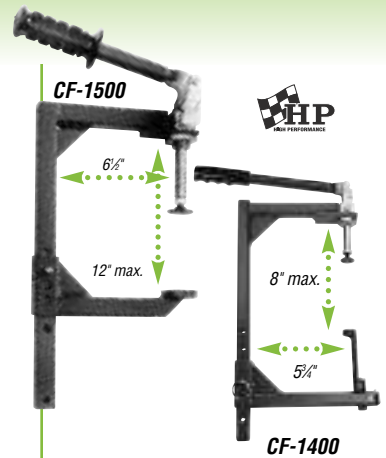

Manual Valve Spring Compressors

- Handle valve springs from a range of applications
- Welded, gusseted all-steel construction takes plenty of abuse • Plenty of leverage to compress valve springs

Description	Jobber	Order No.
High Performance Spring Compressor	\$220.49	CF-1500
Multi-Valve Head Spring Compressor	\$199.99	CF-1400
3/4" Replacement Adaptor for CF-1400	\$49.99	CF-6

Valve Spring Compressor Adaptor

- Fit seat and guide machines or drill press
- Puts collet or drill press chuck behind adaptor
- Allows more room to remove or re-install valve keepers and associated components
- Fits 1/2" collet or Jacobs chuck (not included)

OD (mm)	Reach (mm)	Jobber	Order No.
3/4" (19.1)	3 3/4" (95.3)	\$49.99	CF-6
1 3/16" (20.6)	3 3/4" (95.3)	49.99	CF-8
1" (25.4)	3 3/4" (95.3)	49.99	CF-10
1 1/4" (31.7)	3 3/4" (95.3)	49.99	CF-12
1 1/2" (38.1)	3 3/4" (95.3)	49.99	CF-15



Adaptors for Deeply Recessed Springs

- Open top design gives easy access to keepers
- Durable, non-marring material
- Fit on Split-Jaw Spring Adaptors such as our **CF-44** (p. 37)



Description	OD	Height	Jobber	Order No.
Small Adaptor	26mm	4" (101.6mm)	\$28.79	CF-32
Medium Adaptor	27mm	3" (76.2mm)	24.49	CF-24-G
Large Adaptor	32mm	3" (76.2mm)	24.49	CF-25-G

Keeper Installation Tools

- Spring-loaded plunger • For single & multi-groove keepers • Reaches keeper grooves located farther from the valve tip • Ideal for use with **CF-500** (p. 35) and **PSB-5000** (p. 34)

Size	Jobber	Order No.
4mm / .1563"	\$79.99	VKI-4
5mm / .2031"	79.99	VKI-5
6mm / .2344"	79.99	VKI-6
7mm / .2812"	79.99	VKI-7
8mm / .3125"	79.99	VKI-8
Replacement Rubber Sleeve 5 & 6mm	6.99	VKI-56
Replacement Rubber Sleeve 7 & 8mm	6.99	VKI-78



Keeper Tools

Description	Jobber	Order No.
Keeper Tool	\$ 8.99	CF-842
Keeper Magnet - 6 1/16" holder .170" dia. earth magnet	15.99	VKM-17
Keeper-Keeper - PVC 1/4" holes keep keepers in	15.49	VK-15

Valve Spring Compressors & Accessories

Joe Mondello
Signature Series



Heavy-Duty Manual Spring Compressor

- Drop forged steel frame • 100% American made
- Open receiver design allows quick, easy access to keepers
- Ideal for the shop or track • For springs to 1 3/4" diameter
- 8 1/2" throat • 6" depth • Order No. **CF-1300** Jobber \$379.99



Valve Spring Compressor & Adaptors for 5V Audi & VW

- Simple lever arrangement compresses valve springs • Remove or install keepers by reaching into the open sides of the compression plunger • Mount cross-bar supports to cam-bearing bosses, or any other appropriate studs or bolt holes in the head • CF-300 features 7/8" plunger diameter • CF-301 Adaptor features offset design • Work directly above the valve stem • Adaptor has 23.5mm dia. plunger

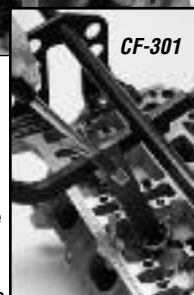

Description	Jobber	Order No.
Valve Spring Compressor	\$169.99	CF-300
Offset Spring Compressor Adaptor for 5V Audi & VW	58.79	CF-301
Keeper Installers	Size	
	4mm	\$74.99 VKI-4
	5mm	74.99 VKI-5
	6mm	74.99 VKI-6
	7mm	74.99 VKI-7
	8mm	74.99 VKI-8

L-Head Manual Spring Compressor

- Easily removes springs in recessed area of valve in block engines
- Handle turns to open and close the compressor
- Integral jaws accommodate springs up to 1 1/8" OD
- Sized for industrial engines - Continental, Waukesha, etc.
- Order No. **CF-122** Jobber \$19.99

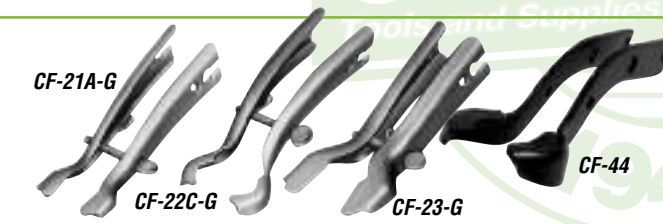

Valve Spring Adaptors

Diameter Range	Jobber	Order No.
.875" - 1.875" (22.2mm-47.6mm)	\$14.99	CF-21A-G
1.00" - 2.000" (25.4mm-50.8mm)	14.99	CF-22C-G
1.50" - 2.500" (38.1mm-63.5mm)	15.99	CF-23-G
1.00" - 1.875" (25.4mm-47.6mm)	13.99	CF-44
Replacement Thumb Screw	3.29	CF-700-2-G

V-Rod Spring Compressor Kit

Extract springs from the V-Rod's deep-set bores in seconds with this Spring Compressor Kit. The adaptor sleeve sits on top of the retainer allowing you to compress the spring. Includes a manual spring compressor, adaptor sleeve, keeper remover and spring loaded installer. Order No. **CF-HDVR** Jobber \$199.99



Heavy Duty Valve Spring Adaptors

- For most common spring compressors
- Welded construction helps prevent jaw kick-off or twisting

Diameter ID	Jobber	Order No.
1.625" (41.275mm)	\$19.99	CF-44HD
1.400" (35.56mm)	24.99	CF-22HD
1.625" (41.275mm)	19.99	CF-23HD

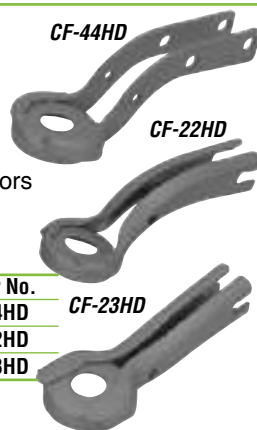

Classic™ Offset Valve Keepers

- 100 pair per container • Heat treated for maximum service life • Patented design • Groove location is moved which repositions the retainer to increase spring tension
- Color coded for easy identification

Application	Jobber	Order No.
5/16" Single Groove	Plus .030"	\$38.99 K5030-100
	Plus .060"	38.99 K5060-100
11/32" Single Groove	Plus .030"	\$38.99 K1030-100
	Plus .060"	38.99 K1060-100
3/8" Single Groove	Plus .030"	\$38.99 K2030-100
	Plus .060"	38.99 K2060-100



Always confirm your coil bind specs when using these keepers

CYLINDER HEAD
REBUILDING

CLEANING,
ASSEMBLY & SAFETY

SHORT BLOCK
REBUILDING

FLYWHEEL GRINDING

CRANKSHAFT/
BRAKE & ALIGNMENT
TOOLS

MEASURING
TOOLS

OFFROAD BIKE, ATV
HARD PARTS

V-TWIN
HARD PARTS

Full Service ...FAST!!



"Our staff of ASE-Certified Techxperts® can help you solve problems fast! Call with questions about product applications, machining precision, longer tool life, improving efficiency, cost savings or any other technical topic. We're here to help you!"

- Jim, Goodson ASE-Certified Master Machinist Technical Support Manager - 20 years of service

Order 5 or more cones,
save 10% off jobber



Small Chamfering Cones & Mandrels Make Deburring and Chamfering Easy In Tight Spaces

These mandrels are available in two diameters - 3/4" and 1 1/2" diameters with a 1/2" shank to fit most portable drills. The small diameter fits easily into tight spaces such as Beehive Valve Springs (see page 133) or bolt holes. The mandrel is designed to support a 60° abrasive cone which is held securely by the retaining ring. One 80-grit cone is included with initial purchase.



Description	Jobber	Order No.
3/4" dia. Mandrel	\$37.99	CC-34
1 1/2" dia. Mandrel	47.99	CC-60
3/4" Dia. Abrasive Cones	80 grit	2.69 CC-35
	120 grit	2.69 CC-36
1 1/2" Abrasive Cones	80 grit	3.99 CC-61
	120 grit	3.99 CC-62

Universal Gel Lube

- Sprays on as a liquid and forms into a gel within seconds
- Penetrating formula blends freely with motor oil
- Multiple uses, including cams, lifters, rocker arms, bearings, pistons/wrist pins, cylinders, etc.
- Provides lubrication for engines subjected to prolonged storage before initial start-up
- Aerosol
- Order No. **GL-8U** Jobber \$17.99



Buy 6 or more cans and save 10% off jobber



See page 8 for our Universal Spring Pad Cutters for use with your 3-angle cutting system



Valve Spring Seat Cutters

- Recut valve spring seats to establish spring-to-valve concentricity or use to enlarge seats for over-size dual springs
- Requires special pilot - see chart

Carbide Tipped Cutter Bodies
(use VP pilots at right)

OD	ID	Order No.
1.320"	.630"	VSS-1320
1.350"	.625"	VSS-1350
1.500"	.625"	VSS-1500
1.550"	.625"	VSS-1550
1.625"	.625"	VSS-1625
1.680"	.750"	VSS-1680HD
1.750"	.625"	VSS-1750

Jobber \$74.99

Hardened & Ground Pilots

(for VSS and VSC cutter bodies)

Stem Size	Order No.
7mm	VP-7MM
5/16"	VP-312
1 1/2"	VP-343
3/8"	VP-375

Jobber \$19.99

Valve Guide OD Machining Tool
on page 25

Buy the kit
and SAVE!

Dial Indicated Valve Stem Height Gauges

- 5 sizes to choose from
- Small diameter extended measuring body allows extra height for dial indicator clearance
- Use with our large-faced Dial Indicator to check valve tip height



Description	Jobber	Order No.	Incl.		
Valve Stem Height Gauge Kit w/Stand	\$249.99	VSH-KIT	▼		
Valve Stem Height Gauge Kit	119.99	VSH-200	▼		
Valve Stem Height Gauge for Harley®	59.99	VSH-HD-KIT	▼		
Dial Indicator (2" travel, .001" graduations)	59.99	MDI-2	x x		
Dial Indicator (1" travel, .001" graduations)	28.99	EDI-1	x		
Measuring Bodies	OD	ID	OAL		
	.750"	.625"	3.830"	\$39.99 VSH-205	x
	.900"	.770"	2.840"	39.99 VSH-203	x
	.900"	.770"	3.840"	39.99 VSH-204	x
	1.060"	.812"	2.840"	39.99 VSH-201	x x x
	1.250"	1.090"	3.300"	39.99 VSH-202	x x
Tool Stand			29.99	TS-5	x
1" Checking Standard			9.99	MCS-1	x

More dial indicators on page 122

CYLINDER HEAD
REBUILDING

CLEANING,
ASSEMBLY & SAFETY

SHORT BLOCK
REBUILDING

CRANKSHAFT/
FLYWHEEL GRINDING

BRAKE & ALIGNMENT
TOOLS

MEASURING
TOOLS

OFFROAD BIKE, ATV
HARD PARTS

V-TWIN
HARD PARTS

Valve Spring Testers

Adjustable Stop

Valve Spring Tester and Height Indicators

Testers

- Test valve and clutch springs up to 2" dia. x 4½" long (50.8x144.3mm)
- 4¼" (107.9mm) dial
- Lbs./kg. ± 1% accuracy
- Height scale: in./mm
- Secondary pointer holds maximum reading
- Adjustable stop

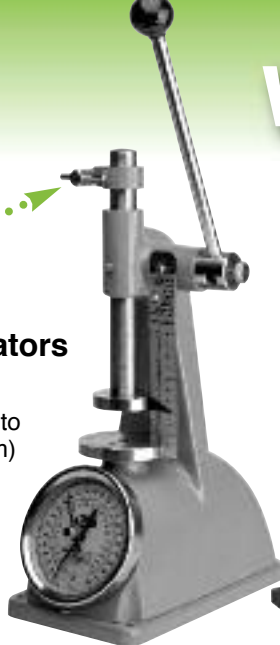

Testers	Range	Increments	Jobber	Order No.
	0-500 lb. / 0-226.8kg	2lb / 2kg	\$979.99	VST-69
	0-1000 lb. / 0-453.6kg	5 lb / 5kg	979.99	VST-70



VST-DS

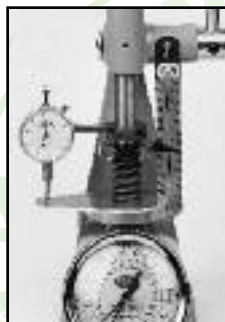

VST-25

Height Indicators

- Measure compressed spring height when testing pressure
- 2 models to choose from – digital or dial
- Ideal for high performance and checking a large number of identical springs • Digital Height Indicator reads inches and metric • Installs easily on **VST-69** and **VST-70**

Height Indicators	Jobber	Order No.
Digital Read-out Height Indicator with mounting kit	\$169.99	VST-DS
Dial Indicated Height Indicator with mounting kit	66.99	VST-25
Mounting Kit for VST-25 (Use with your indicator)	41.99	VST-10
1" Travel Dial Indicator	28.99	EDI-1

For routine calibration of these spring testers, return tester to Goodson. Call for details, 1-800-533-8010.

Check Spring Tester Accuracy With These Calibrated Springs

- Highest-quality spring steel
- Calibrated to show pressure at a specified compressed height (includes calibration certificate) • Color coded for easy identification

Max. Rating	Jobber	Order No.
90 lbs. (41 kg)	\$35.79	VST-95
425 lbs. (193 kg)	41.99	VST-96

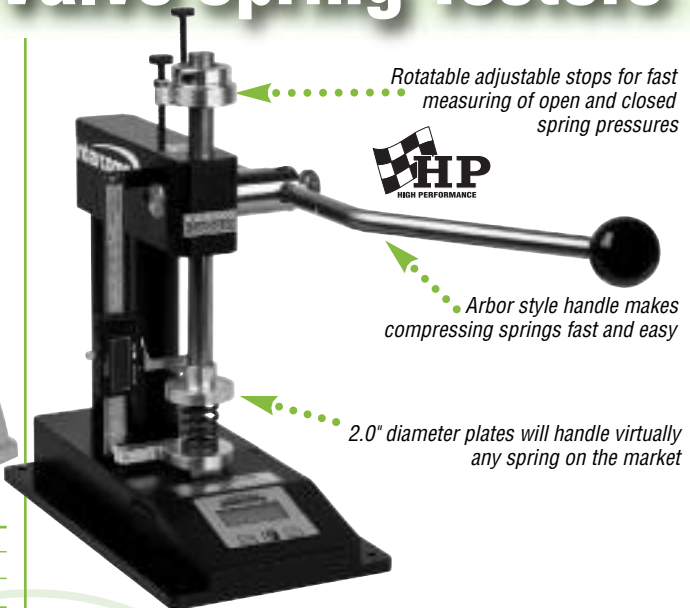
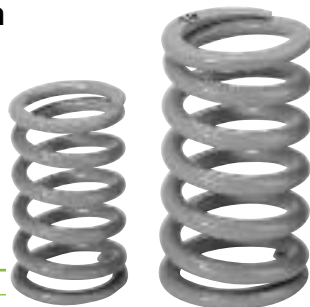

Rotatable adjustable stops for fast measuring of open and closed spring pressures



Arbor style handle makes compressing springs fast and easy

2.0" diameter plates will handle virtually any spring on the market

Intercomp®

Digital Arbor Valve Spring Tester

- 1,500 lb / 680.4 kg Loadcell in 1 lb. increments
- Force units switchable from pounds to kilograms
- Billet 6061 T-6 Aluminum construction
- Digital travel readout at .001"/inch or .01/mm
- 5" travel capacity • 2.0" diameter spring pads
- Easy to read backlit screen
- Operates on 9V battery (included)
- Adjustable stop to repeatedly check springs at the same heights • Order No. **VST-2000** Jobber \$1,299.99

Valve Spring Tester

- Measure spring pressure to ±2% • Compress spring with drill press or vise • Use a ruler or caliper to measure spring height (see page 122 for calipers) • Rugged design



Pressure Range	Jobber	Order No.
0 - 300 lbs. (2 lb. increments)	\$145.99	VST-300
0 - 600 lbs. (5 lb. increments)	162.99	VST-600

What is coil bind and how is it measured?



Coil bind is the point at which a valve spring is fully compressed so that there is no space between the coils. You do **NOT** want your springs to reach this position when in use since it will cause damage to the camshaft and valve train components. To measure coil bind height, install the retainer in the valve spring and compress the spring until the coils are stacked tightly together. Measure from the bottom of the spring to the bottom of the retainer. This is your coil bind height.



CYLINDER HEAD REBUILDING

CLEANING, ASSEMBLY & SAFETY

SHORT BLOCK REBUILDING

FLYWHEEL GRINDING

CRANKSHAFT/ BRAKE & ALIGNMENT TOOLS

MEASURING TOOLS

OFFROAD BIKE, ATV HARD PARTS

V-TWIN HARD PARTS



FREE cabinet with purchase:

Buy 1 box each of A-102, A-103, A-201, A-203 & A-303 Inserts and we'll include the A-5000 cabinet at no extra charge!

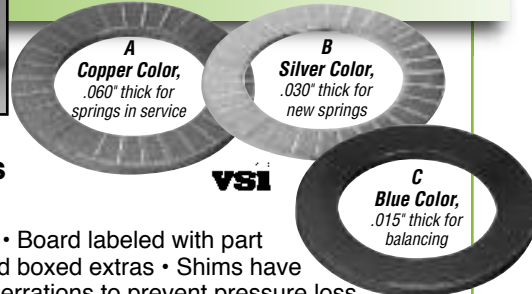

Valve Spring Inserts & Storage Cabinet

- Cabinet features 50 hooks • Board labeled with part numbers • 4 shelves to hold boxed extras • Shims have patented heat dissipating serrations to prevent pressure loss
 - Support valve springs better • Won't compress • Maintains pressure and protects head from spring abrasion • Choose from shim selection below • **Cabinet:** Order No. **A-5000** Jobber \$99.99
- Special Orders are available. Call to inquire. 1-800-533-8010

Size		50 count			100 count		
OD	ID	.060"	.030"	.015"	.060"	.030"	.015"
0.970"	0.445"		B-108-HP				
1.000"	0.688"				A-101	B-101	C-101
	0.765"				A-104	B-104	
1.100"	0.719"					B-106	
1.218"	0.875"				A-105	B-105	
1.250"	0.625"	A-107-HP	B-107-HP	C-107-HP	A-107	B-107	C-107
	0.812"	A-203-HP	B-203-HP	C-203-HP	A-203	B-203	
	0.875"				A-201	B-201	
1.360"	1.000"	A-102-HP	B-102-HP	C-102-HP	A-102	B-102	
1.375"	0.765"	A-301-HP	B-301-HP	C-301-HP		B-301	
1.437"	0.785"	A-305-HP	B-305-HP	C-305-HP			
1.480"	0.703"	A-303-HP	B-303-HP	C-303-HP	A-303	B-303	
1.500"	1.031"	A-103-HP	B-103-HP	C-103-HP	A-103	B-103	
Jobber	\$21.99	\$21.99	\$21.99	\$20.99	\$20.99	\$20.99	\$20.99

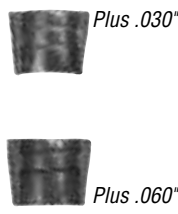
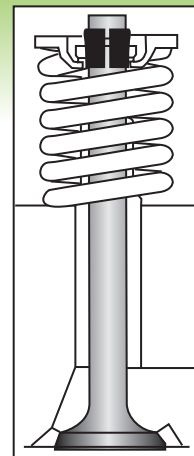

Classic™ Offset Valve Keepers – An Easy To Use Alternative to Valve Spring Shims

- 100 pair per container • Heat treated for maximum service life • Patented design
- Groove location is moved which repositions the retainer to increase spring tension
- Color coded for easy identification

Application	Jobber	Order No.
5/16" Single Groove		
Plus .030"	\$38.99	K5030-100
Plus .060"	38.99	K5060-100
11/32" Single Groove		
Plus .030"	\$38.99	K1030-100
Plus .060"	38.99	K1060-100
3/8" Single Groove		
Plus .030"	\$38.99	K2030-100
Plus .060"	38.99	K2060-100

Always confirm your coil bind specs when using these keepers (see page 39 for Tech Tip).



Cylinder Head CC-ing Equipment

- Use glass buret with alcohol or solvent • Positive on/off fluid control valve • Clear acrylic plate lets you see when the combustion chamber is full

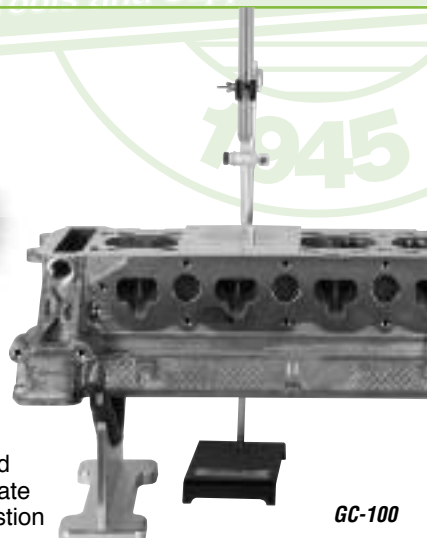

Description	Jobber	Order No.	Incl.
CC-Measurement Kit	\$169.99	CCB-KIT	▼
100cc Glass Buret	99.99	CCB-100	x
5" x 5" x 3/8" Acrylic Plate	10.99	GCB-3	x
Buret Cleaning Brush - 35 1/2" OAL	9.29	GCB-BRUSH	x
Buret Stand	17.99	GCB-1	x
Buret Clamp	17.99	GCB-2	x
Funnel	5.99	CCB-FUNNEL	x
Measuring Liquid Concentrate (Gallon)	10.99	GCB-LIQUID	
4" Starrett Precision Cylinder Head Level	129.99	LEV-4	
Replacement Vial for 4" level	68.29	VGL-101	
100cc Glass Beaker	59.99	GC-100	



Buy both, save 10% off jobber!

Magnets conveniently mounted on both ends of the tool for different sizes of studs and washers



Shims and washers not included

Magnetic Head Bolt Washer & Valve Spring Shim Removal Tools

Avoid injury from sharp VSI removal tools or the ever popular oil shower from using air pressure to remove washers. The hollow design allows easy access over studs or head castings and the powerful earth magnet grabs firmly letting you lift the washer or shim out easily.

Description	Jobber	Order No.
VSI Removal Tool	\$49.99	VSR-1
Head Bolt Washer Removal Tool	49.99	SWR-2

Cylinder Head Resurfacing



Base is CNC-machined from highest quality T-6 Aluminum

2-Way Resurfacing Set-up Level

- Level both directions at once • Top-quality aluminum frame with hardened & ground tool-steel contact pads • Shipped pre-calibrated • Includes Starrett 6" precision vials (LEV-8-1)
- Weighs just 2 lbs.
- Order No. **LEV-TR** Jobber \$269.99



Tech Tip

Precision Levels and Vials

- Graduated vials with satin-chromed, brass protective covers that rotate to close tightly
- Base castings are seasoned, then precision machined and finished on a bearing surface • Replaceable vials
- Adjustable for precise calibration
- 1 division equals .0005" per inch
- Fits pilots as small as 6MM



VGL-100
(pilot sold separately)

Description	Jobber	Order No.	Replacement Vial
4" Valve Guide Level (3" vial)	\$154.99	VGL-100	\$68.29 VGL-101
4" Level (3" vial - nominal)	129.49	LEV-4	68.29 VGL-101
8" Level (6" vial - nominal)	199.49	LEV-8	88.29 LEV-8-1
12" Level (8" vial - nominal)	279.99	LEV-12	96.79 LEV-12-1

Import / Metric Cylinder Head Stud Stretchers

- Save time, don't remove the studs from a head for resurfacing • Put stud stretchers on two studs and leave the rest • Sold in pairs

Length	Thread	Jobber	Order No.
3"	8mm x 1.25	\$51.49	SS-20
3 3/4"	8mm x 1.25	53.79	SS-30
3 3/4"	10mm x 1.25	53.79	SS-40

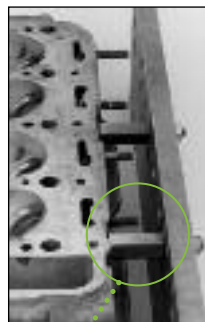

PCD Inserts for Aluminum

- A must for shops committed to meeting today's strict surface finish requirements
- Fits all machines with 3/8" and 1/2" type CBN bit holder • 1/2" diameter tips require shim (included) • Use with Resurfacing Spray (**HPS-16**) for best results (see below)

Size	Jobber	Order No.
3/8" (9.53mm) Diameter	\$179.99	PCDS-375
1/2" (12.7mm) Diameter (shim included)	189.99	PCDS-500

Resharpener service available, call for details.

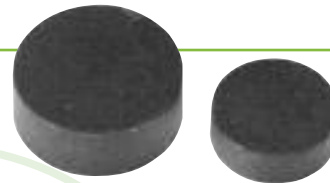

CBN Cutter Inserts

Titanium-Nitride Coated

Dia.	Thick.	Sided	Jobber	Order No.
3/8"	1/8"	Double	\$179.99	CBN-375D
	1/8"	Single	159.99	CBN-375S
1/2"	1/8"	Double	229.99	CBN-500D*
	3/16"	Single	249.99	CBN-500S

Sharp Uncoated

Dia.	Thick.	Sided	Jobber	Order No.
3/8"	1/8"	Single	\$149.99	CBNS-38
1/2"	3/16"	Single	164.99	CBNS-12

Resharpener service available, call for details.

- *NOTE: A 1/16" thick carbide shim must be used with CBN-500D on DCM machines
- Order No. **CBN-500SHIM** Jobber \$21.99



Enlarged for clarity



Diesel Super Abrasive

- Designed for cast diesel heads with hardened pre-cups
- Fits all overhead surfacers with 1/2" diameter tool tip capacity
- Won't chip • Will **NOT** work on standard cast heads
- .500" (12.7mm) diameter • .125" (3.2mm) thick
- Order No. **DRD-500** Jobber \$289.99

NOTE: A 1/16" thick carbide shim (sold separately) must be used with DRD-500 on all DCM machines. Order No. **CBN-500SHIM** Jobber \$21.99

Buy 6 or more cans, save 10% off jobber
Mix or match with High Performance Resurfacer Spray (**HPS-16**), Cutting & Tapping Fluid (**CTF-14**) and Minnesota Fast Freeze (**MFF-8**) to achieve the quantity discount



High Performance Resurfacing Spray

- Prolongs cutter life
- Enhances surface finish
- Refreshing scent • Aerosol
- Order No. **HPS-16** Jobber \$11.99



Cylinder Head Resurfacing Segments



Four keys to resurfacing aluminum heads:

1) Choose the correct abrasive

Use a speckle wheel segment to grind aluminum heads.

2) Lubricate, lubricate, lubricate

Put a light coat of **Grind-Aid** (**GRA-10**) on the abrasive to reduce aluminum build-up on the wheel. Speed up the traverse and reduce the cut to .0005" - .001" per pass.

3) Dress for success

To keep grains open, dress the wheel often. Don't dress before the last pass but be sure to apply Grind-Aid liberally to let the stone give a finer surface finish.

4) Keep heat build-up to a minimum

The greatest danger is heat build-up that can cause scoring as aluminum transfers to the stone. Avoid this by taking shallow cuts and using plenty of coolant.

SAVE!
Buy a complete set of 8 or more segments and take 10% off jobber!

Silicon-Carbide Abrasive

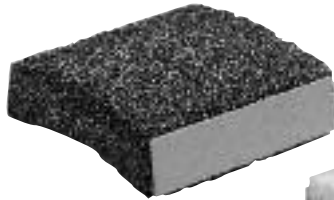

Aluminum Oxide Abrasive



Aluminum Oxide & Silicon-Carbide Abrasive



Aluminum Oxide Abrasive (ruby)



Colors may vary

Resurfacing Wheel Segments

Segments are available in a variety of compositions. Match the abrasive to the material for best results and longest life. Order segments in 8, 10 or 12 piece sets. Also sold individually.

Width	Thickness	Length	Application	Abrasive	Jobber	Order No.
2.56"/65mm	0.98"/25mm	3.94"/100mm	Cast Iron & Aluminum	Silicon-Carbide	\$18.99	GS-PBS
			Steel & Hardened Metals	Aluminum Oxide	21.99	GS-PBS-1
			Aluminum, Cast Iron, Hardened Iron & Steel	Aluminum Oxide and Silicon-Carbide	20.99	GS-PBS-2
			Steel & Hardened Metals	Aluminum Oxide	19.99	GS-PBS-3

For Peterson/Peterson Berco 1055 AWL, RSC950 (std.), SYP320, -360, -1000, -1300, RSC1200, -1550 RPYS1500 models. For Winona Van Norman SM-2000, SM-4000/5000, MG-4000, SM-6000C/6000A and MG-3000/3850 models. For Storm Vulcan RT7Y Late (Serial No. 103152 and up) and RT 17Y Late (Serial No. 128697 and up) models.

3.13"/79mm	0.81"/21mm	3.13"/79mm	Cast Iron & Aluminum	Silicon-Carbide	\$18.99	GS-SVS
			Aluminum, Cast Iron, Hardened Iron & Steel	Aluminum-Oxide and Silicon-Carbide	20.99	GS-SVS-2

For Peterson/Peterson Berco RG-32, RTY, RG-35, RG-300/900 models.

For Storm Vulcan RT 7Y Early (Serial no. up to 103151) and RT 17Y Early (Serial no. up to 128696)

1.97"/50mm	0.67"/17mm	3.62"/92mm	Cast Iron & Aluminum	Silicon-Carbide	\$17.99	GS-RGS
			Aluminum, Cast Iron, Hardened Iron & Steel	Aluminum-Oxide and Silicon-Carbide	17.99	GS-RGS-1

For Peterson/Peterson Berco RG-35 and RG-300/900 models

2.56"/65mm	0.79"/20mm	3.94"/100mm	Steel & Hardened Metals	Aluminum Oxide	\$19.99	GS-KWS
			Aluminum, Cast Iron, Hardened Iron & Steel	Aluminum-Oxide and Silicon-Carbide	20.99	GS-KWS-2

For Kwik-Way 858 and 862 models

NOTE: To maintain proper cutting action Goodson strongly recommends that you replace your cylinder head resurfacing segments in full sets. See your user's manual for wheel diameter and number of segments required. Need help choosing the abrasive? Call the Goodson Techxperts™

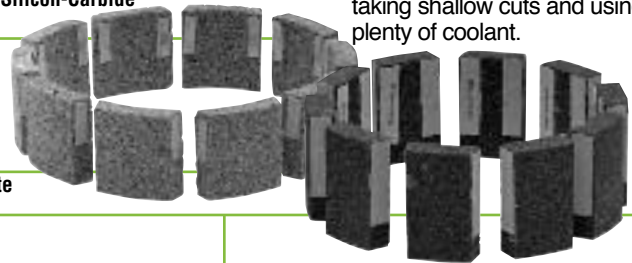

Resurfacing Segments are guaranteed for 1 year from original purchase date

Buy 6 or more tubes, save 10% off jobber!

Grind Aid

- Cools & lubricates
- Stops premature grain fracturing • Reduces glazing and loading
- Improves surface finish
- Essential when resurfacing aluminum heads • Handy twist tube with cover
- Order No. **GRA-10** Jobber \$17.49

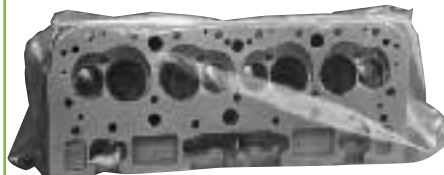

Cylinder Head Storage Bags

- 3 mil thickness
- 17"x44" / 43.2 cm x 111.8cm
- 100 per roll
- Order No. **BC-17** Jobber \$66.29

More storage bags on page 68

Rust Shield Aerosol

- Choose between short & long term protection
- Spray on right after resurfacing



Formula	Jobber	Order No.
Short Term	\$12.99	RS-16
Long Term	16.79	RS-16-OD

Order 6 or more cans, save 10% off jobber!



CYLINDER HEAD REBUILDING
CLEANING, ASSEMBLY & SAFETY
SHORT BLOCK REBUILDING
CRANKSHAFT/ FLYWHEEL GRINDING
BRAKE & ALIGNMENT TOOLS
MEASURING TOOLS
OFFROAD BIKE, ATV HARD PARTS
V-TWIN HARD PARTS

Cylinder Head Resurfacing Belts

**Buy 3 or more,
save 10% off jobber**

**Buy 5 or more,
save 15% off jobber**



Cylinder Head Resurfacing Belts

A belt has three important parts: abrasive, bond and backing. Goodson belts are made for top performance and long life. Our belts also feature a unique splice that permits use in both directions for even longer wear; when worn one way, turn belt around to resurface more heads.

Abrasive: Match the abrasive to the workpiece (aluminum, cast iron or steel) and to your machine for the longest belt life.

Bond: Double-layer, heat-resistant resin holds abrasive firmly. Bond is so strong that grains wear out instead of loosening.

Backing: Waterproof, poly-back belt won't tear or fray. It's the toughest backing of any resurfacing belt.



Selection Guide: which abrasive works best on what materials...	
STEEL	Ceramic (40g)
	Nor-Zon® (40g)
CAST IRON	Aluminum-Oxide (40g)
	Silicon-Carbide (40g)
	Silicon-Carbide (80g)
ALUM	Silicon-Carbide (80g)

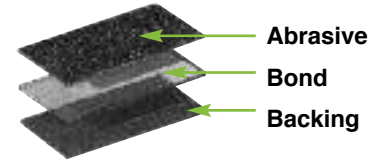

To check which size belt is needed to fit your machine, see the groups of resurfacers listed below.

Belt Fits these Sizes machines

Silicon-Carbide 40-grit:

- Good-quality • Black
- Primarily for cast iron but can resurface aluminum if extra care is used
- Down-pressure optional

Silicon-Carbide 80-grit:

- Good-quality • Black
- Designed especially to resurface aluminum
- Down-pressure not recommended

Ceramic 40-grit:

- Best-quality • Maroon
- Perfectly uniform grain • Outlasts other types of belts • For cast iron or steel
- Down-pressure recommended

Nor-Zon® 40-grit:

- Better-quality • Blue
- Grains fracture under pressure to stay sharp
- For cast iron or steel
- Down-pressure recommended

Aluminum-Oxide 40-grit:

- Good-quality • Red
- OE standard for most machines
- For cast iron only
- Down-pressure optional

COLORS FOR REFERENCE ONLY ... DUE TO MANUFACTURING PROCESS, ACTUAL COLORS MAY VARY • RESURFACING BELTS ARE GUARANTEED FOR 1 YEAR FROM ORIGINAL PURCHASE DATE

	Jobber	Order No.	Jobber	Order No.	Jobber	Order No.	Jobber	Order No.	Jobber	Order No.
11 7/8" x 76" (A)	\$51.99	SGS-11-76	\$47.99	SGA-11-76			\$57.99	SGB-11-76		
11 7/8" x 79" (B)	39.99	SGS-11-79	39.99	SGA-11-79			64.49	SGB-11-79		
11 7/8" x 89" (C)	51.99	SGS-11-89	39.99	SGA-11-89			67.99	SGB-11-89		
11 7/8" x 91" (D)	57.99	SGS-11-91	44.99	SGA-11-91						
14" x 86" (E)	64.49	SGS-14-86-60*	47.99	SGA-14-86						
14" x 103" (F)	67.99	SGS-14-103	44.99	SGA-14-103			99.79	SGB-14-103		
14" x 107" (G)	76.49	SGS-14-107	47.99	SGA-14-107			104.79	SGB-14-107		
14" x 113 1/2" (H)	76.79	SGS-14-113	57.99	SGA-14-113	\$129.99	SCB-14-113	109.79	SGB-14-113	\$84.99	SGR-14-113
15" x 127 1/2" (I)	89.99	SGS-15-127	61.99	SGA-15-127	149.99	SCB-15-127	124.49	SGB-15-127	99.79	SGR-15-127

A) Winona Van Norman BG-600 B) RMC, Peterson RG-1203 C) RMC-800, Serv-Equip PG-1229 D) Peterson RG-1234 & Kansas Instruments E) Automotive Craftsman F) Master Tool G) Kwik-Way 870 Master Surfer H) Storm Vulcan / Anderson AB-1000A, Peterson PG-1400 I) Storm Vulcan / Anderson AB-1540A, Anderson AB-1540, IDL HS-4350, Peterson PG-1500, Winona Van Norman BR-1500, BG-1515 & BG-1520 *36-grit belt *60-grit belt



Belt Resurfacer Coolant

- Semi-synthetic
- Rust-inhibiting
- For ALL belt resurfacers with a coolant sump
- Pink • Dilute 30:1

Quantity	Jobber	Order No.
1 gallon (3.78 liters)	\$ 26.99	SGB-10
5 gallon (18.93 liters)	129.99	SGB-50

Save 10% on 10!

Order 10 or more Resurfacing Carbide Cutter Tips OR Rotary Broach Tool Bits and SAVE 10% off jobber



Rotary Broach Tool Bit For Van Norman 530, 570 & VM-2000

- One-piece cutter
- Order No. VN-65C Jobber \$19.99

Resharpener service available, call to inquire
Jobber \$9.99

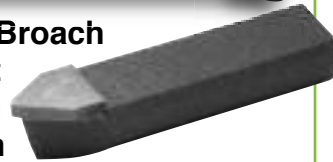

SV-85BE

FC-858-3

Enlarged for clarity

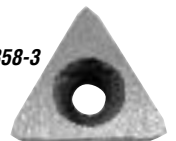

Carbide Cutter Replacement Tips For Broach Style Surfers

Fits	Jobber	Order No.
Storm Mill 85, 85B, 85BE, 85C, 85N & 280	\$28.99	SV-85BE
KW-858	32.49	FC-858-3

same day shipping on orders placed by 6pm (central)

CYLINDER HEAD REBUILDING

CLEANING, ASSEMBLY & SAFETY

SHORT BLOCK REBUILDING

CRANKSHAFT/FLYWHEEL GRINDING

BRAKE & ALIGNMENT TOOLS

MEASURING TOOLS

OFFROAD BIKE, ATV HARD PARTS

V-TWIN HARD PARTS

Cylinder Head Resurfacing

CYLINDER HEAD REBUILDING
CLEANING, ASSEMBLY & SAFETY
SHORT BLOCK REBUILDING
CRANKSHAFT/ FLYWHEEL GRINDING
BRAKE & ALIGNMENT TOOLS
MEASURING TOOLS
OFFROAD BIKE, ATV HARD PARTS
V-TWIN HARD PARTS



Surface Grinding Coolant

- Synthetic • Water soluble • Non-foaming
- Non-nitrate • Dilute 20:1 • Always use ample coolant to keep your cutting surface cool and to flush away grinding debris

Size	Jobber	Order No.
1 Gal. (3.78 L)	\$ 29.99	SGC-10
5 Gal. (18.93 L)	129.99	SGC-50

Single-piece Resurfacer Wheels

- Meet or exceed OE standards established for general purpose grinding applications • Silicon-Carbide abrasive • Banding will wear off to expose more abrasive

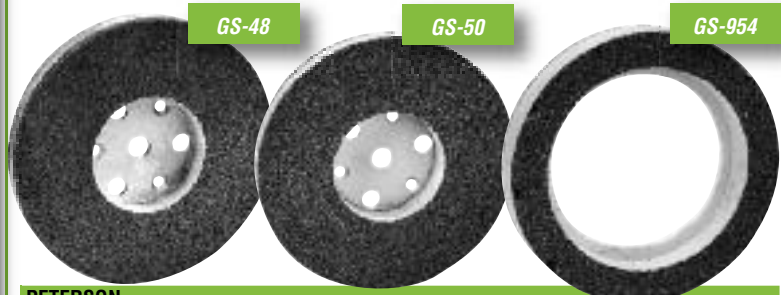

PETERSON

Machine Model(s)	Size: dia. x height x face width	Grit	Jobber	Order No.
All 14" Dry Grinders	14" x 1½" x 4" Plate	36	\$349.99	GS-48
All 14" Dry Grinders	14" x 1½" x 4" Plate	24	369.99	GS-50
1054	16" x 2" x 2" Inserted Nut	16	344.99	GS-954



KWIK-WAY

Machine Model(s)	Size: dia. x height x face width	Grit	Jobber	Order No.
545,545H,855	12" x 3" x 1½" (Serrated) Plate	16	\$385.99	GS-545
545B,856,855-5,860	14" x 3" x 1½" (Serrated) Plate	24	459.99	GS-545B
545BL,860A, L & T	16" x 3" x 1½" (Serrated) Plate	24	499.99	GS-545BL

Grinding Wheels are guaranteed for 1 year from original purchase date



Easy to read LCD digital readout



Probe adjusts for a variety of measuring positions

- **Ra** - Average Roughness
- **Rz** - Maximum Roughness Depth (DIN)
- Meets ANSI, ISO, DIN & MIL Specifications
- Supports multiple cut-off and traverse settings
- Convenient digital display located on top
- Easy to read 3 digit LCD readout
- Roughness in microinches or micrometers
- Vee Base for location on round parts
- Battery "Low" Indicator
- Works on standard 9V Alkaline battery (not included)
- Includes fitted case, standard and probe
- Includes Test Block and Calibration Certificate

Ra & Rz Portable Surface Roughness Tester

Use the Portable Surface Roughness Tester for a variety of surface roughness assessments including flat, inside/outside diameters and many difficult to gauge test surfaces. Featuring a durable cast housing and designed for shop use, this roughness tester will provide years of reliable and accurate surface finish assessments. It's also designed to take measurements from a variety of positions and several angles. It works on horizontal and vertical surfaces and can even be used upside down. Includes foam lined plastic storage case.

- Order No. **PST-4** Jobber \$2,299.99

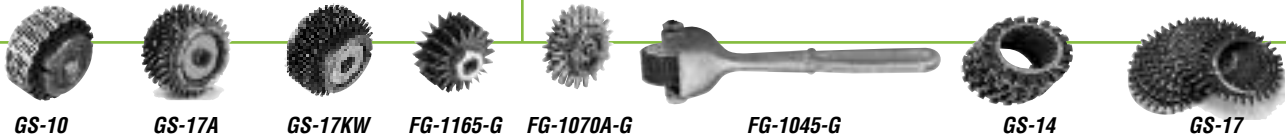

Grinding Wheel Dressers & Replacement Cutters

Applications	Cutter Assemblies				Replacement Cutters					
	OD	ID	W	Jobber	Order No.	Pieces	Washers	Size	Jobber	Order No.
VN, Lempco, Storm RT-7Y, 17Y	2.500"	1.500"	.0625"	\$84.99	GS-10	14 stars	1 w/locking tangs	1.75" x .058"	\$21.99	GS-14
Peterson (12mm shaft)	2.375"	1.500"	.0938"	84.99	GS-17A	8 stars	5 1 locking	2" x 1.50" x .028" 1.75" x 1.5" x .06"	21.99	GS-17
Kwik-Way	2.375"	1.500"	.0938"	84.99	GS-17KW	8 stars	5 1 locking	2" x 1.50" x .028" 1.75" x 1.5" x .06"	21.99	GS-17
WVN SM2000, 4000, 5000, 6000C, 6000A, MG3000, 3850	1.250"	0.313"	.0625"	29.99	FG-1165-G	7 stars	none	1.25" x .313" x .095"	7.99	FG-1161-G
Peterson & DCM	2.375"	1.125"	.125"	63.99	FG-1070A-G	5 stars	1	1.624" dia. x .031"	15.99	FG-1070-G
Hand held				77.99	FG-1045-G	1 stone	none	1.500"x.313"x.625"	13.99	FG-1044-G

Pistol Grip Vacuum Tester

CYLINDER HEAD REBUILDING
CLEANING, ASSEMBLY & SAFETY
SHORT BLOCK REBUILDING
FLYWHEEL GRINDING
CRANKSHAFT/ BRAKE & ALIGNMENT TOOLS
MEASURING TOOLS
OFFROAD BIKE, ATV HARD PARTS
V-TWIN HARD PARTS



Pressure gauge is located on the top of the tester and angled for easy reading

Pressure relief valve
Exhaust port filter keeps the vacuum running smoothly and quietly
DVC-2011 comes complete with pistol grip and a 4.75" vacuum plate. Other plates shown on next page

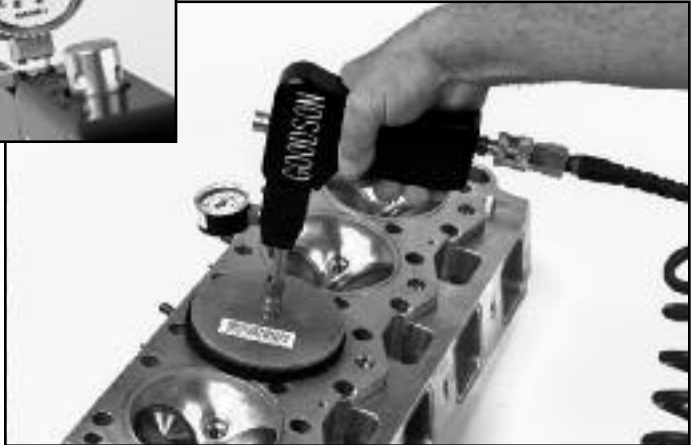

New!

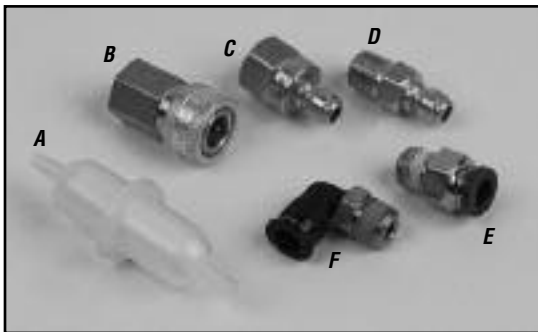

Optional Hose Kit includes 3 feet of 1/4" Air Line, L-Fitting, Filter, Straight Fitting, Robinair Fitting and Straight Coupler. All parts are also available separately



Exclusive

Portable

This lightweight Pistol Grip Vacuum Tester (only 1.9 lbs. without the plate) can easily be taken to the work-piece – whether in the shop or at the track.

Powerful

Easily pulls and holds up to 24 PSI negative vacuum. Requires as little as 90 PSI.

Fast

Quick coupling Robinair fittings make switching plates fast and easy.

Simple

Controls are placed to allow single-handed operation, leaving you a free hand for other tasks.

Heavy-Duty

The Pistol Grip Vacuum Tester is ergonomically designed for more comfortable use. It is made of hard-anodized billet aluminum for years of reliable service.

Flexible

Add the optional Flexible Hose Kit (DVC-2011-HK) and smaller size plates (sold separately) to reach previously inaccessible areas to test for leaks.

Serviceable

A wide range of replacement parts are available, allowing you to keep your unit in top shape at all times.

Ordering Information

Description	Jobber	Order No.
Pistol Grip Vacuum Tester Kit with 4.75" Vacuum Plate	\$499.99	DVC-2011
Flexible Hose Kit	36.99	DVC-2011-HK
Optional Vacuum Plates		
2.00" / 50.8mm Diameter Vacuum Plate	\$20.99	DVC-2
3.00" / 76.2mm Diameter Vacuum Plate	23.99	DVC-3
4.75" / 120.7mm Diameter Vacuum Plate	28.99	DVC-475
6" / 152.4mm Diameter Vacuum Plate	30.99	DVC-6
2"x3" / 50.8x76.2mm Vacuum Plate	21.99	DVC-23
3"x4" / 76.2x101.6mm Vacuum Plate	26.99	DVC-34
Replacement Parts		
1/8" NPT "L" Fitting (F)	\$ 3.99	CF-2003-L
1/8" NPT Female Coupling (B)	12.29	LDP-AR-6
Inline Air Filter (A)	10.99	DVC-FILTER
1/8" x 1/4" Straight Fitting (E)	5.99	DVC-SF
Nipple Coupling (C)	6.99	DVC-1N
Robinair Fitting (D)	5.29	DVC-SN
1/8" NPT Male Coupling	14.99	DVC-1M
Plate Lube	5.99	DVC-PL
3' Air Line	lin. ft. price 1.99	CF-2001-AL



WorldwideShipping

Vacuum Testers & Accessories

CYLINDER HEAD
REBUILDING

CLEANING,
ASSEMBLY & SAFETY

SHORT BLOCK
REBUILDING

CRANKSHAFT/
FLYWHEEL GRINDING

BRAKE & ALIGNMENT
TOOLS

MEASURING
TOOLS

OFFROAD BIKE, ATV
HARD PARTS

V-TWIN
HARD PARTS

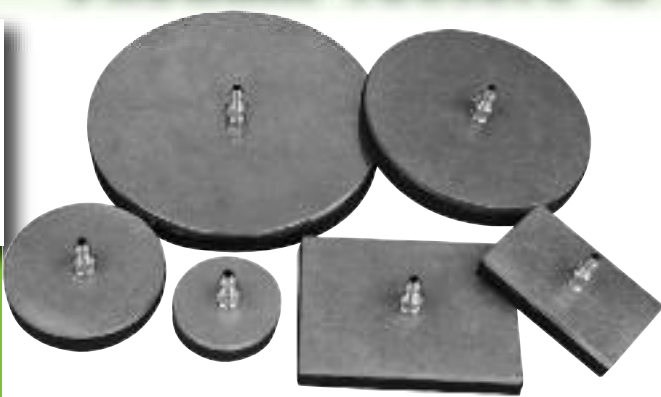

Vacuum Tester Plates

- Closed cell foam for an exceptional seal
- Replacement foam also available separately
- Several sizes to choose from or ask for a custom size
- Plate lube improves the seal for even better vacuum holding power
- Plate Kits below include Plate Lube (DVC-PL)

Universal Replacement Plates with Robinair fittings

Size	Jobber	Order No.	Incl.
Robinair Fitting Replacement Plate Kit	\$119.99	DVC-7KIT	▼
2" / 50.8mm dia.	20.99	DVC-2	x
3" / 76.2mm dia.	23.99	DVC-3	x
4.75" / 120.7mm dia.	28.99	DVC-475	x
6" / 152.4mm dia.	30.99	DVC-6	x
2"x3" / 50.8 x76.2mm	21.99	DVC-23	x
3"x4" / 76.2 x 101.6mm	26.99	DVC-34	x
Replacement Robinair Fitting	5.29	DVC-SN	

Sioux-Style Replacement Plates for the 1630K Tester

Size	OE No.	Jobber	Order No.	Incl.
Sioux-Style Fitting Replacement Plate Kit	\$179.99	SVT-7KIT	▼	
2" / 50.8mm dia.	1630-2	26.99	SVT-2	x
3" / 76.2mm dia.	1630-3	29.99	SVT-3	x
4.75" / 120.7mm dia.	1630-4	37.99	SVT-475	x
6" / 152.4mm dia.	1630-6	40.99	SVT-6	x
2"x3" / 50.8 x76.2mm		30.99	SVT-23	x
3"x4" / 76.2 x 101.6mm		36.99	SVT-34	x
Replacement Sioux-Style Fitting		13.49	DVC-SX	

Accessories & Replacement Parts

Description	Jobber	Order No.
6 Pc. Replacement Foam Set - 1 of each size	\$31.99	FOAM-KIT
Plate Lube - 4 oz. / 118.3mL	5.99	DVC-PL
Replacement Line Filter	10.99	DVC-FILTER
Replacement Mat - 11" x 31" x 3/8"	39.99	DVC-1131

Is there a special size you need? Call 1-800-533-8010 to inquire.

Vacuum Testing

Vacuum testing is the fastest method for testing valve to valve seat integrity. Simply assemble your machined cylinder head and install the spark plugs. Use a reliable vacuum source producing approximately 24 lbs. HG on the vacuum gauge and a closed cell foam test plate with a through fitting to draw down or evacuate the combustion chamber.

Once you've reached 24 lbs. HG on the gauge and close the vacuum to the chamber. Watch the gauge for a drop in vacuum. It should hold steady confirming that you have achieved valve to seat mating.

Coat the face of your closed cell foam test plate with Plate Lube to condition the foam. This produces a soft, yielding material that will fill minor head surface blemishes or imperfections.



Heavy Duty Manual Vacuum Tester

- Cover combustion chamber with rigid foam backed plate and pump vacuum
- A steady reading of 25" (63.5cm) indicates proper valve seating
- All metal construction
- Instructions, 4 1/4" plate and fittings included
- Any DVC Plate from chart at left will fit this tester
- Includes a tapered spark plug adaptor



Description	Jobber	Order No.
Manual Vacuum Tester	\$149.99	DVC-101-HD
Replacement 4.75" Plate	28.99	DVC-475

NOTE: Any DVC Plate from chart at left will fit this tester

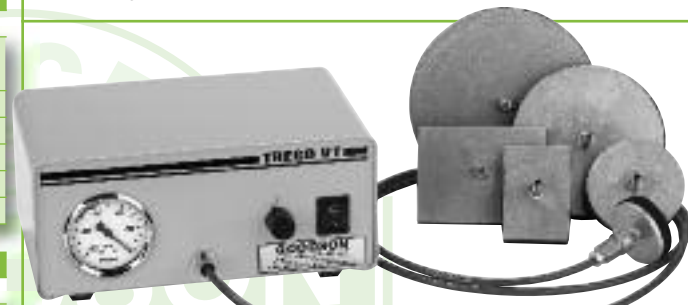

Handy toggle switch turns the unit on and off



Inline filter keeps debris out of the unit for longer life and more power



Vacuum control knob has three settings - Continuous, Hold and Release

Trego Electric Vacuum Tester

Check valve-to-seat seal right on the bench or in the engine compartment - no special set-up required! This unit is equipped with a vacuum piston pump and generates up to 850 mbar of vacuum. A built-in pressure difference control allows you to control vacuum settings accurately. Gauge reads in Mbar and PSI; no need for conversion formulas.

Specifications	
Maximum Vacuum:	850 m.bar
Electric Motor:	115 V, 60 Hz, 67 Watt
Dimensions:	9 1/2" L x 6 3/4" W x 4 1/2" H
Shipping Weight:	8 lbs.

This unit is lightweight and portable, allowing you to take it right to the assembled engine to diagnose problems before you start disassembly. The complete kit includes the vacuum tester, vacuum tube complete with connectors and filter, 6 vacuum plates and 4 oz. Plate Lube for better vacuum seal. Optional accessories include an 11" x 31" foam pad. Order No. VT-KIT Jobber \$1,399.99

Parker Magnetic Crack Detection Units

CYLINDER HEAD
REBUILDING

CLEANING,
ASSEMBLY & SAFETY

SHORT BLOCK
REBUILDING

FLYWHEEL GRINDING

CRANKSHAFT/
TOOLS

MEASURING
TOOLS

OFFROAD BIKE, ATV
HARD PARTS

V-TWIN
HARD PARTS



Exclusive

MMP-100

MMP-210

Articulating legs adjust to a wide range of angles, allowing you to test uneven surfaces with ease

New!

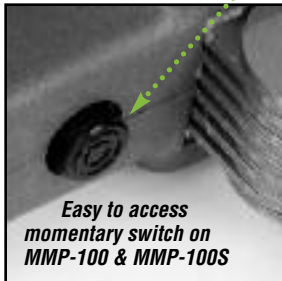

Easy to access momentary switch on MMP-100 & MMP-100S



Top-mounted momentary switch on MMP-210 & MMP-210S

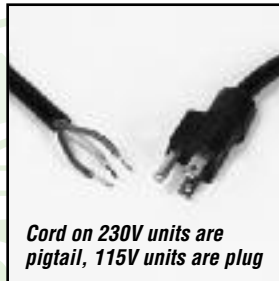

Cord on 230V units are pigtail, 115V units are plug



Parker Research Corporation, the originator of the flexible-leg magnetic inspection yoke has been manufacturing portable Magnetic Particle Inspection Equipment and accessories for over forty years. Goodson is proud to bring these top-of-the-line units to the automotive aftermarket.

Specifications



MMP-100 / MMP-100S

- Physical: 7³/₈" x 9¹/₄" x 2¹/₈"
187 x 235 x 54mm
- Max. Span: 12" (304.8mm) across poles
- Voltage: 115V (MMP-100)
230V (MMP-100S)
- Line Current: 4 amp (MMP-100)
3 amp (MMP-100S)
- Weight: 6.5 lb (2.95 kg)
- Cord: 10' L, 3-wire



MMP-210 / MMP-210S

- Physical: 10¹/₂" x 11" x 2³/₄"
266 x 280 x 70mm
- Max. Span: 18" (457mm) across poles
- Voltage: 115V (MMP-210)
230V (MMP-210S)
- Line Current: 8 amp (MMP-210)
3 amp (MMP-210S)
- Weight: 13 lb (5.9 kg)
- Cord: 10' L, 3-wire

Versatile

Articulating legs allow these crack detectors to conform to virtually any surface configuration. These units can also be used to demagnetize components – simply follow the supplied instructions.

Portable

Designed for one-person operation, these crack detectors are lightweight and can be taken to the worksite in their protective case. No transformer box to drag around!

Powerful

All of our units produce a strong, AC magnetic field that is applied to a precise area for fast, reliable inspection. Units have a 50% duty cycle; for example, 2 minutes on, 2 minutes off. 115V and 230V models are available.

Guaranteed

All models carry a full 1-Year Manufacturer's Warranty for repair or replacement.

American Made

Ordering Information

Description	Jobber	Order No.
115V Electronic Crack Detector with 10# Pull	\$414.99	MMP-100
115V Heavy Duty Electronic Crack Detector with 22# Pull	519.99	MMP-210
230V Electronic Crack Detector with 10# Pull	419.99	MMP-100S
230V Heavy Duty Electronic Crack Detector with 22# Pull	519.99	MMP-210S
Accessories		
Magnetic Powder 1 lb. Yellow	\$9.99	WCD-101-G
Large Area Applicator Bulb	19.99	WCD-266-G
Magnaflux® Residual Magnetism Indicator	67.99	CR-2480

Additional Magnetic Crack Detection Accessories & Supplies on page 48

Magnaflux® Crack Detection Units

CYLINDER HEAD
REBUILDING

CLEANING,
ASSEMBLY & SAFETY

SHORT BLOCK
REBUILDING

CRANKSHAFT/
FLYWHEEL GRINDING

BRAKE & ALIGNMENT
TOOLS

MEASURING
TOOLS

OFFROAD BIKE, ATV
HARD PARTS

V-TWIN
HARD PARTS



Y-7

Legs adjust to accommodate irregular surfaces

An intense magnetic field is created in the area between the yoke legs. Any surface cracks will create flux leakages that will attract magnetic particles that form indications that allow for detection.

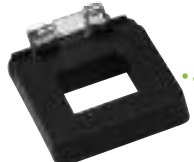

Slim molded light easily fits on the leg of the Y-6, & Y-7 Yoke (below) to illuminate the inspection area. Light works only in AC mode when yoke is activated. Meets ASTM E 1444 visible light requirement of 100 foot candles. Lets you use the yoke in darkened area.



Easy-to-access switch makes going from AC to DC quick.

MAGNAFLUX®

Y-7 AC/DC Crack Detection Yoke

- Designed for reliable, one-person magnetic particle inspection of ferrous parts
- Fully portable and fits into tight spaces • Finds surface defects in AC mode and near-surface defects in DC mode • Adjustable, double-jointed legs contour easily to any component shape to assure good contact • 0-11"/0-28cm leg capacity
- Pull force of 10 lbs/4.54kg AC and 60 lbs/27.2kg DC complies with specifications
- Solid state controls in housing for maximum safety and reliability
- 2 minute ON/OFF duty cycles for fast, efficient inspections
- Use with **MAGNAFLUX®** Dry Non-Fluorescent powders • Carrying case included

Y-7 Yoke Specifications

- Current Draw: 115V, 50/60 Hz
- Line Draw: 9 amps @ 115V AC
4 amps @ 115V DC
- Demag: Yes in AC mode
- Yoke Weight: 7.4 lbs. (3.6kg)
115V
- Leg Capacity: 0" - 12" (0-30cm)
across poles
- Cord: 9 ft. (274.32cm)
with grounded plug
- Other: Carrying case & instructions included

Model	Voltage	Cycles	Amps	Weight	Jobber	Order No.
Y-7	115	50/60 Hz	9 AC / 4 DC	7.4 lbs. / 3.4 kg	\$829.99	MF-43550
Light Attachment for Y-7 Yokes only					49.29	MF-621785

Non-Fluorescent Magnetic Powder for Dry Method Particle Inspection

- Works with all dry magnets, including Magnaflux® yokes above
- Store in a moisture free environment



Size	Jobber White	Jobber Yellow	Jobber Red
1 lb.	\$ 9.99 WCD-100-G	\$ 9.99 WCD-101-G	\$ 9.99 WCD-103-G
5 lb.	29.99 WCD-500-G	29.99 WCD-501-G	31.99 WCD-503-G
25 lb.	109.99 WCD-2500-G	154.99 WCD-2501-G	149.99 WCD-2503-G

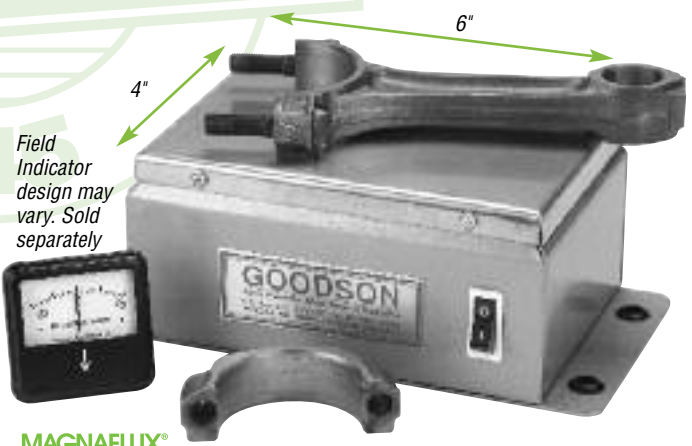

Field Indicator design may vary. Sold separately

MAGNAFLUX®

Small Parts Demagnetizer

Don't jeopardize your engine work! Heat, friction and magnetic particle inspection can cause magnetism to build up in your engine components. If not removed, it will attract ferrous materials in engine lubrication and may cause premature engine failure. This easy to use table demagnetizer is a fast and easy way to ensure that all residual magnetism is eliminated from engine components. Use with the optional Field Indicator to be sure all remaining magnetism is eliminated.

Description	Jobber	Order No.
Small Parts Demagnetizer	\$79.99	SPD-46
Magnaflux® Field Indicator	67.99	CR-2480

Magnetic Powder Applicators

- A quick & easy method for distributing Magnaflux® powder
- | Description | Jobber | Order No. |
|-----------------------------------|---------|------------------|
| Atomizer Assembly for small areas | \$28.99 | MM-301 |
| Applicator Bulb for large areas | 19.99 | WCD-266-G |
| Replacement Bulb for Atomizer Jar | 11.99 | MM-301-1 |



Crack Detection



GOODSON Glow Blacklight Crack Detection Kit

- Easily detect surface cracks that could be missed
- Cracks & flaws glow brightly under black light

Description	Jobber	Order No.	Incl.
Goodson Glow Kit - AC	\$129.99	GLO-KIT	▼
Cleaner Aerosol	19.99	GLO-1	x
Penetrant Aerosol	20.99	GLO-2	x
Developer Aerosol	23.99	GLO-3	x
AC Blacklight	84.99	GLO-4	x
5 Cloth Towels	3.99	WST-5	x
Replacement Bulb for GLO-4	45.99	GLO-4-B	
Magnaflux Aerosol Developer	25.29	ZP-9F	
Magnaflux Aerosol Penetrant	29.49	ZL-27A	
Mix or match Cleaner, Penetrant & Developer to make a case of 12 and SAVE 10% OFF Jobber.			

Tech Tip

Keep all Ultra-Violet and Black Lights a minimum of 18" from magnetic fields to prevent damage to the tungsten element and voiding the warranty.



Ultra-Violet Light Inspection

- Put into a running engine to find hidden leaks
- Check engines, transmissions and radiators **IN** the vehicle
- Use before disassembly to plan repairs • Use after rebuilding to ensure satisfaction, or to find and fix warranty complaints
- Add dye to oil, coolant or fluid • No pre-cleaning
- Run vehicle briefly to distribute the dye • Inspect with UV light • Finds even the tiniest of leaks

Description	Jobber	Order No.
Light	150W-110VAC light assembly	\$529.99 GLO-300
Replacement Bulbs	150W-110VAC bulb only (Model 1610)	159.99 GLO-150WB
	120W-110VAC bulb only (Model 1210)	159.99 GLO-120WB
Lens	Ultra-violet lens	63.99 GLO-LENS
Dyes	Automatic Transmission Dye	10.99 GLO-ATD
(1 oz./29.6mL)	Antifreeze Dye	10.99 GLO-CAD
	Oil Dye for gasoline engines	10.99 GLO-GED

Identify surface cracks in minutes!

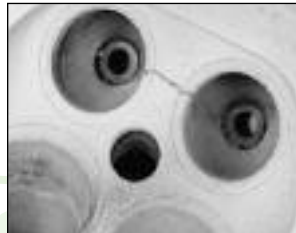

Alumni-Chek

- Find surface cracks on aluminum & cast iron without electricity or special lights
- Ideal for aluminum, but also works on brass, cast-iron, steel, carbide, and stellite • Even the tiniest cracks show as bright red • Complete kit includes cleaner, penetrant, developer and shop towels (also available separately)

Description	Jobber	Order No.
Complete Kit	\$46.99	AC-KIT ▼
Cleaner Aerosol	19.99	AC-1 x
Penetrant Aerosol	19.99	AC-2 x
Developer Aerosol	19.99	AC-3 x
5 Towels	3.99	WST-5 x

Mix or match Cleaner, Penetrant & Developer to make a case of 12 and SAVE 10% OFF Jobber!



Crack Detection Powders and Sprays

- For wet method crack detection
- Mix powder with oil carrier, or order pre-mixed aerosol
- Use **GLO-300** (left) Light to view results

	Size	Jobber	Order No.
Powder	4 oz.	\$33.99	CR-14A-4
	1 lb.	125.99	CR-14A
Oil Carrier	5 gal.	119.99	CR-50
Prepared Bath Aerosol	12 oz.	17.79	CR-14AM

MAGNAFLUX®



Magna-Fluro Oil

- Oil impregnated with Magnaglo® powder (**CR-14**) to glow under black-light • Low viscosity
- Flows easily into small cracks
- Oil clarity makes cracks easier to see

Description	Jobber	Order No.
Aerosol 12 oz.	\$ 29.99	MFA-12
5 gallon /18.93 liter	129.99	MFA-50

CYLINDER HEAD REBUILDING

CLEANING, ASSEMBLY & SAFETY

SHORT BLOCK REBUILDING

FLYWHEEL GRINDING

CRANKSHAFT/ BRAKE & ALIGNMENT TOOLS

MEASURING TOOLS

OFFROAD BIKE, ATV HARD PARTS

V-TWIN HARD PARTS

Full Service ... FAST!



"At Goodson, we're always on the lookout for new or improved tools that make engine rebuilding easier. If you have a tool you think we'd be interested in, give us a call."
- Dave, Goodson National Sales Manager, 17 yrs. of service

CYLINDER HEAD
REBUILDING

CLEANING,
ASSEMBLY & SAFETY

SHORT BLOCK
REBUILDING

CRANKSHAFT/
FLYWHEEL GRINDING

BRAKE & ALIGNMENT
TOOLS

MEASURING
TOOLS

OFFROAD BIKE, ATV
HARD PARTS

V-TWIN
HARD PARTS



shown actual size



melted center
reveals overheating



Heat Tabs

- Provides visual evidence of engine overheating
- Special heat sensitive metal centers melt and fall out when engine exceeds the melting point of the tab • Marine Heat Tabs are sold in packs of 50, all others are 100 per pack
- Attach to heads with Heat Tab Adhesive (below)

Description	Melting Point	Jobber	Order No.
Heat Tabs	255-260° F / 124-127° C	\$52.49	HT-100
Round Heat Tabs	255-260° F / 124-127° C	52.49	HT-100RD
Diesel Heat Tabs	225-235° F / 107-110° C	52.49	DHT-100
Marine Heat Tabs	187-192° F / 86-89° C	59.99	MHT-50
Heat Tab Adhesive (3 oz./88.7mL tube)		9.29	HTA-3



Protect yourself from unjustified warranty claims with a simple Heat Tab

When you attach a heat tab to the engine block it provides visual evidence that an engine has been overheated. A special heat sensitive metal has been formed into the center of the tab. When an engine reaches the tab's melting point, this metal will melt and flow out. This is a positive method of determining that a rebuilt engine has been heated beyond normal operating temperature, voiding the warranty. Attach a Heat Tab to the upper portion of the block or to the cylinder head casting with **HTA-3** Aluminum Paste (above). **DO NOT** attach to manifolds or shielding.

Leak Detection Mat

- Commercial-grade Neoprene • Resists petroleum products, abrasion, swelling, sunlight and aging
- Repair or make custom Leak Detection Plates • Mat measures 3'x4'x1/8" thick (914.4x1219.2x3.175mm)
- Order No. **LDP-34MAT**
Jobber \$68.99



Seal-All™

- Seals pin holes, porosity and small cracks in heads & blocks • Penetrates and seals • Out-performs ceramics
- Bonds with existing rust & corrosion to prevent spread • Heat at 175°-200°F (79.4°-93.3°C) for 4 hours to cure
- Not for use on assembled engines

Size	Jobber	Order No.
32 oz. (946 mL)	\$ 48.29	CPS-32
1 gallon (3.78 liter)	167.99	CPS-128



Fluid Weld®

- For cast iron or aluminum heads and blocks
- Use as a sealant for threaded or press-fit parts like valve guides and seats, threaded crack repair plugs, replacement studs, etc. • Also seals small cracks
- Withstands temperatures up to 3000° F
- Non-toxic • Non-flammable
- Not for use on assembled engines

Size	Jobber	Order No.
2 oz. (59 mL)	\$31.49	FW-2
8.8 oz. (260 mL)	99.79	FW-88



Ceramic Motor Seal

- Seals porosity in the cooling system to increase engine power • Inhibits rust formation and salt water corrosion during normal operation • 16 oz./455 mL
- Order No. **CRS-16**
Jobber \$16.79



All Weather Seal

- Works in less than 5 minutes • Seal minor cracks and leaks in the cooling system • Fast-acting, non-corrosive, non-clogging
- Can be used with coolant or anti-freeze
- 16 oz./455 mL
- Order No. **AWS-16**
Jobber \$14.79



Engine Seal Tabs Seal And Prevent Leaks In Any Cooling System

- Use in a running engine
- For water leaks in cylinder heads, blocks, radiators, water pumps, heater cores, manifolds, etc.
- 3 1/2 gram tablets treat up to a 9 quart cooling system
- 20 tabs per pack
- Order No. **EST-10** Jobber \$29.49

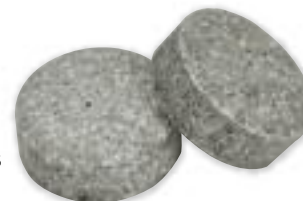

Crack & Thread Repair



Threaded Plugs

Tapered, threaded plugs, cast to rigid specifications. Order Installation tooling listed to right of plug size desired.

Plug Size	Qty.	Jobber	Iron	Jobber	Order No.
.200" x 1 5/16"	100	\$99.99	CRP-200	\$5.99	CRD-200
.200" x 1 1/2"	100	79.99	CRP-201	5.99	CRD-200
.235" x 1 5/16"	100	99.99	CRP-235	5.99	CRD-235
.327" x 1 3/8"	50	84.99	CRP-327	6.99	CRD-327
.386" x 3/4"	50	59.99	CRP-386		
.590" x 1"	25	59.99	CRP-590		

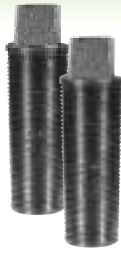

H.S.S. Drills

High-strength steel, 118° points for fast chip removal



Tapered Reamers

High-strength steel tapered for precise plug installation



Tapered Taps

High-strength steel machined to match plugs taper & thread



Jobber	Order No.	Jobber	Order No.
Not Required		\$ 62.99	CRT-200
Not Required		62.99	CRT-200
\$ 73.49	CRR-235	57.79	CRT-235
110.29	CRR-327	73.49	CRT-327



Machinable Spray Welding Powder

General Purpose Cast Powder

- Ideal for valve seat face surfaces, combustion chambers, blocks and manifolds
- Use with **your** spray welding torch

Color Match Powder • Matches colors well

Cast Crank Powder • For cast cranks and cams

Description	Jobber	Order No.
General Purpose	\$77.99	SWP-6
Color Match	77.99	SWP-7
Cast Crank	77.99	SWP-8



.235" Crack Repair Kit

- For the cold-repair process
- Includes all items listed below in a handy carrying case

Description	Jobber	Order No.
Complete Repair Kit: 100 - .235" x 1 5/16"	\$329.99	CRK-150
Threaded Iron Plugs	99.99	CRP-235
High Strength Steel Drill	5.99	CRD-235
High Strength Steel Tapered Reamer	73.49	CRR-235
High Strength Steel Tapered Taps (2)	57.79	CRT-235
Cut-Off Saw with Blade	27.29	CR-SAW
Replacement Saw Blade	11.79	CR-BLADE
7.5 oz. Tap Oil	15.79	TAP-O
All Weather Seal	14.79	AWS-16
16 oz. Ceramic Seal	16.79	CRS-16

Jet Valve

Eliminator Kit

Some Mitsubishi/Chrysler 2.6L heads had jet valves while some didn't. This kit lets you use a jet valve head in place of one without. 11mm diameter, 1.0 pitch threaded plugs replace entire valve body assembly. Easier than welding the holes closed. Package of 4 converts one 2.6L head • Order No. **JVE-26** Jobber \$26.99



Head-Bolt Hole Cleaner

- Cleans threaded holes to prevent false torque wrench readings
- Lifts rust, dirt, chips and other debris as you remove the tool
- Repairs minor damage
- Use with lube and a socket wrench or slow drill

Size	Pitch	Jobber	Order No.
1/2"	13	\$59.99	BCT-1/2
3/16"	14	49.99	BCT-7/16
Extra Long Clean Out Tap 8" long shank			
11mm x 1.5mm (4.6 Ford)		\$111.99	BCT-11L

Rust Inhibitor for Pressure Testing

- Clear fluid inhibits rust and does not discolor or cloud the test tank solution
- Lets you see better to pressure test
- Biocide and anti-rust additives extend tank solution life while preventing corrosion
- Synthetic formula
- Mix 20:1 with water
- Yields 20 gallons
- Order No. **PRI-10** Jobber \$30.99



PROBLEM: Due to poor lubrication, the rear bushing on the upper balance shaft of Mitsubishi built Chrysler 2.0L engines galls to the shaft and spins. Repairing the damaged bore is costly and often requires another block.

SOLUTION: This kit eliminates both balance shafts so the original block can be reused, saving money and ending future shaft problems. It also reduces total friction and improves oil flow to the head. Some vibration may occur at idle, but engine operation is unaffected by balance shaft removal.



Balance Shaft Eliminator Kits For Mitsubishi-Built Engines

- Includes 2 bushings (44 & 45mm), oil pump plug & Welch plug • Order No. **BSE-20** Jobber \$36.99

Convert your Bridgeport-type mill into a cylinder head machining center!



Left: Use a standard socket wrench to back the stud out of the head



Right: Installer OD is 3/4", fits standard socket



Stud Removal and Installation Tooling

- Size stamped for easy identification
- Installers include a steel ball inside to prevent overtightening on the stud
- Removers have a 3/4" OD Hex body with a 5/8" hex jam nut on top
- Available in SAE and metric
- Storage case included with kit
- Available individually or in sets

Description	Jobber	Installers	Jobber	Removers
SAE Tooling				
Stud Installer Set	\$139.99	ASI-7KIT ▼	\$199.99	ASR-7KIT ▼
1/4" Fine	19.99	ASI-250 x	28.99	ASR-250 x
5/16" Fine	19.99	ASI-312 x	28.99	ASR-312 x
3/8" Fine	19.99	ASI-375 x	28.99	ASR-375 x
3/8" Coarse	19.99	ASI-375C x	28.99	ASR-375C x
7/16" Fine	19.99	ASI-437 x	28.99	ASR-437 x
1/2" Fine	19.99	ASI-500 x	34.99	ASR-500 x
9/16" Fine	19.99	ASI-562 x	34.99	ASR-562 x
Metric Tooling				
Stud Installer Set	\$76.99	MSI-3KIT ▼	\$84.99	MSR-3KIT ▼
6 x 1.0	21.99	MSI-6 x	28.99	MSR-6 x
8 x 1.25	21.99	MSI-8 x	28.99	MSR-8 x
10 x 1.5	21.99	MSI-10 x	28.99	MSR-10 x

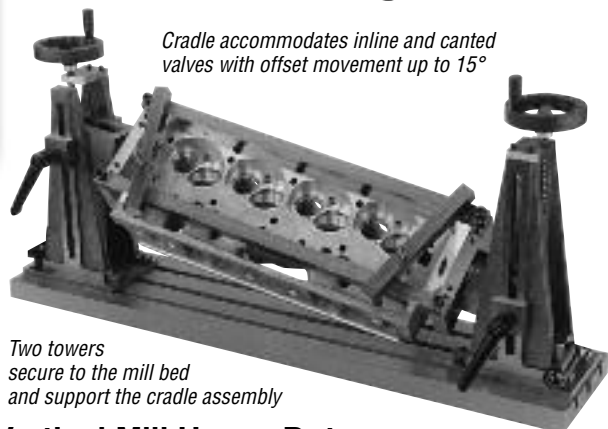

Cradle accommodates inline and canted valves with offset movement up to 15°

Two towers secure to the mill bed and support the cradle assembly

Vertical Mill Heavy-Duty 360° Roll-Over Fixture

- Uses the Universal Quick-Mount Bar Set (included) to hold the workpiece securely in place
- Position workpieces quickly & accurately
- Locks to your table using your standard T-nuts
- Handles workpieces up to 24" long
- Width adjusts in 1/4" increments
- Instructions included
- Quick-Mount Bar Set can also be used as a replacement on most popular seat & guide machines including the Winona **PH-2000 & PH-6000**

Description	Jobber	Order No.
Roll-Over Fixture with Quick-Mount Bar Set	\$1,969.99	VM-42
Replacement Quick-Mount Bar Set	149.79	QMB-95

See more at www.Goodson.com

GM Vortec Adaptor Plate Set For Van Norman & Storm-Vulcan Rotary Broaches

- Required when using the Van Norman VN 530 / 570 or Storm-Vulcan 850 Storm-Mill Rotary Broaches
- Two plate set
- Includes fasteners
- Order No. **VN-VOR** Jobber \$99.99

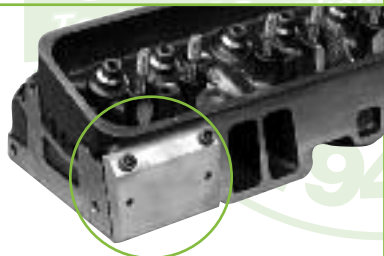

.015" Head Saver Shims

- Shim cam towers if more than .015" is removed when resurfacing head
- Restores valve clearance & timing
- For most 4, 5 & 6-cylinder gas or diesel engines
- Each set shims all cam towers in one head
- Order No. **MHS-40** Jobber \$12.99



CHC-10



Chevy Conversion Plate Set

- Convert early model, 6-bolt heads for late model, 7-bolt applications
- Works with stock exhaust systems
- Use the standard exhaust manifold gasket or seal with High-Temp Silicone

Description	Jobber	Order No.
Conversion Plate Set (screw included)	\$26.99	CHC-10
High-Temp Silicone Sealer (3 oz.)	11.99	CHP-03

Rocker Arm Pedestal Shims

- Compensate rocker arm/push rod distance after head/block machining
- Use original rocker arm specs
- 50 per pack
- .020" thick

Application	Jobber	Order No.
Ford 302/351	\$11.99	RASF-20-50
Ford 302/351	22.99	RASF-20-100
GM 3.1L, V6	19.99	RASG-20-50
GM 3.1L, V6	79.99	RASG-20-100



CYLINDER HEAD REBUILDING

CLEANING, ASSEMBLY & SAFETY

SHORT BLOCK REBUILDING

CRANKSHAFT/ FLYWHEEL GRINDING

BRAKE & ALIGNMENT TOOLS

MEASURING TOOLS

OFFROAD BIKE, ATV HARD PARTS

V-TWIN HARD PARTS

Miscellaneous Cylinder Head Work

Manual Rocker Arm Stud Puller

- Heavy-duty ball bearing action
- Creates less stress and friction • Fits $\frac{5}{16}$ " (7.9mm) and $\frac{3}{8}$ " (9.53mm) threaded studs

Description	Jobber	Order No.
Complete Stud Puller	\$119.99	SP-600
Drive Nut	23.99	SP-601
Puller Body	49.99	SP-602
$\frac{5}{16}$ " and $\frac{3}{8}$ " Mandrel	49.99	SP-603
Thrust Bearing	11.99	SP-604



Rocker Arm Stud Conversion Kit

- Convert pressed-in rocker arm studs to threaded studs
- Remove stud, face stud boss, then drill and tap the stud hole
- Use with a seat and guide machine

Description	Jobber	Order No.	Incl.
Conversion Kit	\$102.99	S-450-KIT	▼
Stud Boss Facer	89.99	S-450-F	x
$\frac{3}{8}$ " Drill Bit	10.99	S-373D	x
$\frac{7}{16}$ " x 14 Thread Tap	19.99	S-437T	x
$\frac{3}{8}$ " Pilot	19.99	S-373P	
V8 Chevy Tap Guide	39.99	S-350G	

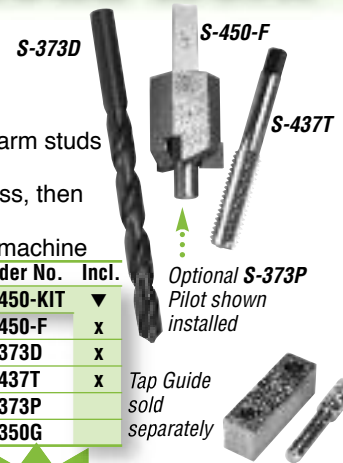

Optional S-373P Pilot shown installed

Tap Guide sold separately



15/16" diameter

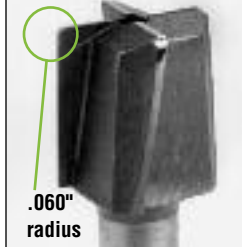

Head Bolt Spot Facer

- Spot face head bolt seat parallel to new deck surface after angle milling
- Allows proper head bolt torquing
- Cutting tip radius matches OE design to avoid stress points and cracks

Description	Jobber	Order No.
Spot Facer	\$99.99	HBF-15
$\frac{7}{16}$ " Pilot	18.79	GFP-437

Torque-Angle Indicator

New Style

- When torque is given as degrees of turn past a certain ft./lb., use this gauge to show degrees
- $\frac{1}{2}$ " square drive
- Hold base with one hand
- Dial turns as you tighten
- Fits between a socket-driven extension and the socket
- Order No. TQR-4554 Jobber \$29.99



Two Blade Spot Facer

- $1\frac{1}{4}$ " OD Spot Facer located on $\frac{3}{8}$ " stud
- Removes unneeded material for easier removal and installation of screw-in studs
- Replaceable carbide blades

Description	Jobber	Order No.	Incl.
Stud Boss Facer	\$129.49	SBF-5587	▼
Replacement Stud Boss Facer $\frac{3}{8}$ " Pilot	27.99	SBF-5587P	
Stud Boss Facer Tip (each) for SBF-5587 only	21.79	SBF-5587T	x
Stud Boss Facer Screw (each)	5.49	SBF-5587S	x

More on page 31

Universal Threaded Stud Extractor

- Use with your pneumatic impact tools & sockets ($\frac{15}{16}$ " socket removes, $1\frac{1}{16}$ " installs)
- Requires only $\frac{3}{4}$ " clearance to adjacent studs
- For threaded studs only • Hardened 3-jaw clamping system • Internal taper support • Hollow body allows long studs to extend through the tool
- $1\frac{1}{2}$ " dia. x $2\frac{1}{4}$ " long • $\frac{1}{4}$ " - $\frac{1}{2}$ " range



Description	Jobber	Order No.
Universal Stud Extractor	\$149.99	PSR-500
Replacement Parts		
Jaws	68.99	PSR-JAWS
Spring Set	5.99	PSR-3S
Snap Ring	3.99	PSR-SR

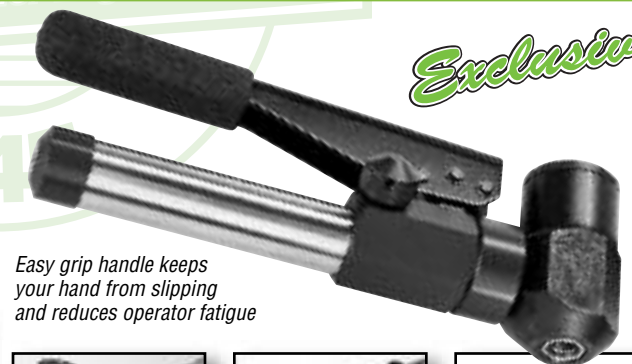

Exclusive

Easy grip handle keeps your hand from slipping and reduces operator fatigue



Hydraulic Stud Puller

American Made

- 25 pounds of handle pressure will create 8 tons of force
- Works on thermally cleaned head castings
- Can be operated in virtually any position
- 1" stroke travel • $\frac{3}{8}$ " x 24 TPI mandrel included with kit

Description	Jobber	Order No.
Hydraulic Stud Puller Kit	\$539.99	SP-8000
Replacement Mandrel - $\frac{3}{8}$ " x 24 TPI	29.99	SP-8001
Replacement Mandrel - $\frac{3}{8}$ " x 24 TPI	29.99	SP-8002

CYLINDER HEAD REBUILDING
CLEANING, ASSEMBLY & SAFETY
SHORT BLOCK REBUILDING
CRANKSHAFT/FLYWHEEL GRINDING
BRAKE & ALIGNMENT TOOLS
MEASURING TOOLS
OFFROAD BIKE, ATV HARD PARTS
V-TWIN HARD PARTS

From our customers



"Goodson came through with custom sized valve grinding tools. My 92 year old Pierce Arrow needed a valve job before a road trip to the West Coast. We completed the 4800 mile trip without a problem."
 -Marlin Hansen, White Bear Lake, MN, Goodson customer since 2007

Aluminum Cylinder Head Straightening Fixture

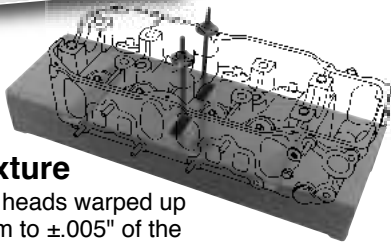

- Straightens aluminum heads warped up to .040", returning them to $\pm .005$ " of the original
- Easy to use
- Top-quality, Mehonite fixture is rigid as 3" steel yet weighs less
- Stress-relieved then milled to .001"
- Can resurface fixture if necessary
- Complete Fixture includes shim stock and all hardware
- 29"L for 4-cylinder & most 6-cylinder
- Order No. **HSF-500** Jobber \$339.99



Pre-drilled mounting flanges to securely mount the oven in position

Temperature Indicating Crayons



Buy 3, get 10% off jobber

- Verify temperature quickly and easily
- Mark the workpiece before heating
- Melts when temperature is reached
- 3 temperatures to choose from

Melting Point	Jobber	Order No.
450°F/232.22°C	\$16.99	TIC-450
500°F/260.00°C	16.99	TIC-500
600°F/315.56°C	16.99	TIC-600

Interior capacity of 35" x 15" x 15" is large enough to accommodate most heads. Shown with our Head Straightening Fixture (sold separately).



Electric Benchtop Aluminum Head Straightening Oven

- Reaches temps up to 550°F / 287.8°C making it ideal for straightening aluminum heads and pre-heating for welding
- MIG welded 10 gauge steel housing
- Electric heating coils
- 220V, 60 Hz single phase
- 2 hour automatic shut-off timer
- Cabinet measures 40"W x 30"H x 21"D
- Interior dimensions: 35"W x 15"H x 15"D
- Use with our straightening fixture above, left
- 1-year warranty on heating element
- Ready to be hard-wired into your shop's electrical service

Description	Jobber	Order No.
Aluminum Head Straightening Oven	\$2,499.99	DHR-34
Heating Element	79.99	DHR-34E
Thermostat Control Unit	159.99	DHR-34T

Precision Straight Edges



Description	Jobber	Order No.
24" straightedge, 1 precision edge	\$ 54.99	PSE-24
35" straightedge, 1 precision edge	79.99	PSE-100
24" straightedge, 2 precision edges	154.99	DIS-20
35" straightedge, 2 precision edges	167.99	DIS-30

26" Round Warp Gauge

- Use with feeler gauges page 55

Description	Jobber	Order No.
3/4" dia. tool steel, 26" long	\$125.99	EWG-100

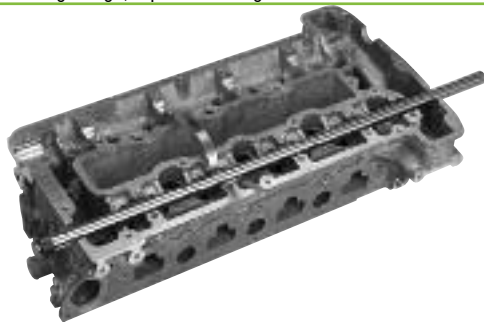

Brass or Steel Shim Stock Packs

- A handy assortment • 4" x 6" each (120 sq. in.)
- One each of .001", .002", .003", .005", .010" thick

Description	Jobber	Order No.
Brass	\$12.99	SSB-50
Steel	12.99	SSS-51

Use with our Head Straightening Fixture and Oven above

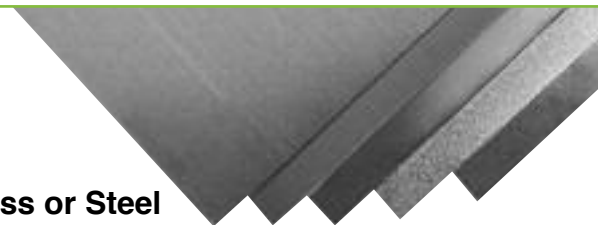

CYLINDER HEAD REBUILDING

CLEANING, ASSEMBLY & SAFETY

SHORT BLOCK REBUILDING

CRANKSHAFT/ FLYWHEEL GRINDING

BRAKE & ALIGNMENT TOOLS

MEASURING TOOLS

OFFROAD BIKE, ATV HARD PARTS

V-TWIN HARD PARTS

Valve Adjustment

Adjust Clearance Between Valve Stem and Cams with Valve Adjustment Discs



- Ideal for most import engines • To select the Valve Adjustment Disc for your job consult the Manufacturer's Specifications for the correct diameter and thickness

Diameter	Thicknesses included	4-Packs of Individual Sizes Jobber Order No.
27mm	2.00, 2.05, 2.10, 2.15, 2.20, 2.25, 2.30, 2.35, 2.40, 2.45, 2.50, 2.55, 2.60, 2.65, 2.70, 2.75, 2.80, 2.85, 2.90, 2.95, 3.00	\$16.49 VAD-(thick)MM-27
28mm	2.50, 2.55, 2.60, 2.65, 2.70, 2.75, 2.80, 2.85, 2.90, 2.95, 3.00, 3.05, 3.10, 3.15, 3.20, 3.25, 3.30	17.79 VAD-(thick)MM-28
31mm	3.05, 3.10, 3.15, 3.20, 3.25, 3.30, 3.35, 3.40, 3.45, 3.50, 3.55, 3.60, 3.65, 3.70, 3.75, 3.85, 3.90, 3.95, 4.00, 4.05, 4.10, 4.15, 4.20	15.49 VAD-(thick)MM
34mm	2.20, 2.25, 2.30, 2.35, 2.40, 2.45, 2.50, 2.55, 2.60, 2.65, 2.70, 2.75, 2.80, 2.85, 2.90, 2.95, 3.00, 3.05, 3.10, 3.25, 3.30	17.79 VAD-(thick)MM-TY

VADs are NOT sold by application, but by diameter and thickness. Please consult manufacturer's specifications before ordering.



Magnetic VAD Holder

No more waiting for a special size – take an existing size and grind it to the size you need right on your valve refacer. Powerful magnets hold the discs securely while you resize them. Tabs keep the VADs from sliding off the holder while grinding. Order No. **VDR-UNI** Jobber \$80.49 Replacement Magnet **VDR-MAG** Jobber \$5.99

Tech Tip

Resize VADs at your shop quickly and easily

Has this happened to you? You're adjusting the clearance between the valve stem and the cams and the stock Valve Adjustment Disc (VAD) isn't the right thickness. You need a 2.25 in a 28mm diameter and the thinnest ones available are 2.50. What are you going to do?

You could wait to have them resized by your supplier, but hey, you're a machinist! You have all of the tools and abilities right in your shop to modify the VADs you have into the VADs you need.

Place the VAD that you need to resize on your Magnetic VAD Holder (VDR-UNI, above). The magnets will hold it securely. Using your Valve Grinder's stem end wheel, grind the VAD to the thickness you need. You're now ready to install it in the head. All in a few minutes instead of a few days.

12" Feeler Gauges

- Use to measure piston-to-wall clearance when honing, to find ring end gap and to check cylinder heads with a straight-edge
- Also useful for shimming while straightening heads and for machine set-ups

Thick	Jobber	Order No.
Complete Kit	\$43.99	FE-KIT ▼
.0015"	5.99	FE-0015 x
.0020"	5.99	FE-002 x
.0030"	5.99	FE-003 x
.0040"	5.99	FE-004 x
.0050"	5.99	FE-005 x
.0060"	5.99	FE-006 x
.0070"	5.99	FE-007 x
.0080"	5.99	FE-008 x
.0090"	5.99	FE-009 x
.0100"	5.99	FE-010 x
.0150"	5.99	FE-015 x
.0200"	5.99	FE-020 x



VAD Adjusting Tools For Toyota

- Reach around the cam to depress the lifter • Wedge holds the lifter down to free the valve clearance disc • Reach in to remove and replace the disc • For most models prior to 2004

Description	Jobber	Order No.
Pliers and Wedge	\$46.99	VBT-40
Wedge only	14.99	VDL-20

Universal Gel Lube

- Sprays on as a liquid and forms into a gel within seconds • Penetrating formula blends freely with motor oil • Multiple uses, including cams, lifters, rocker arms, bearings, pistons/wrist pins, cylinders, etc. • Provides lubrication for engines subjected to prolonged storage before initial start-up • Aerosol
- Order No. **GL-8U** Jobber \$17.29



Spray Assembly Lube

- Ideal for prelubricating parts to ease assembly
- Eliminates critical initial run-in of new and rebuilt high-performance engine components
- Spray on bearings, crankshafts, pistons, rings, etc.
- Aerosol • Order No. **SAL-11** Jobber \$10.99



Save 10% off jobber when you buy 6 or more

Buy 6 or more cans and save 10% off jobber



From our customers:



"At HighOutput Engineering, we are all about Performance and Quality. That is what you get when you work with the staff at Goodson!"

- Jim Haines HighOutput Engineering, LLC, Goodson customer since 2007

Aluminum Oxide Cloth Utility Shop Rolls

- 1" x 50 yards
- Easy to use ... just unroll and tear to length
- Use with butterfly mandrels below

Grit	Order No.
60	UR-1-60
80	UR-1-80
100	UR-1-100
120	UR-1-120
180	UR-1-180

Jobber \$17.99

Crocus Cloth

- Must be used with Lapping Oil
- Great for final touch-ups on cranks, rod pins, valve stems, cams, etc.

Description	Jobber	Order No.
1" x 50 yd. Roll	\$29.99	UR-1-CROCUS
½ pint Very Fine Lapping Oil	10.99	LP-LO



Porting & Polishing Machining Aid

- Use sparingly
- Designed for aluminum
- For porting & polishing operations using cartridge rolls, rotary files, emery cloth or Cross Buffs®
- Dramatically improves surface quality
- Safe for cast iron • 32 oz./946.4mL
- Order No. **PF-32** Jobber \$39.99

Replacement Abrasive Packs and Mandrels

Abrasive Grinding Discs (Quick Change)

Box of 50

Dia.	Grit	Jobber	Order No.
1½"	80	\$23.99	AGD-15-80
2"	80	24.99	AGD-2-80

Surface Conditioning Discs (Quick Change)

Box of 10

Dia.	Grade	Jobber	Order No.
1"	Med.	\$ 8.99	SCD-1M
	Coarse	8.99	SCD-1C
2"	V. Fine	10.99	SCD-2VF
	Med.	10.99	SCD-2M
	Coarse	11.99	SCD-2C

Quick Change Pad Holder

Diameter	Jobber	Order No.
1" dia.	\$12.49	SCD-1H
2" dia.	14.99	SCD-2H

Slotted Butterfly Mandrels

Length	Jobber	Order No.
3"	\$5.99	BM-3
6"	8.99	BM-6
8"	9.99	BM-8
10"	10.99	BM-10
12"	11.99	BM-12

25' Porting Abrasive Rolls

Grit	Jobber	Order No.
50	\$9.99	PR-50
60	9.99	PR-60
80	9.99	PR-80
100	9.99	PR-100
120	9.99	PR-120
150	9.99	PR-150
180	9.99	PR-180

Roll Mandrels

½" pilot x ¼" dia.

Length	Jobber	Order No.
2¾"	\$ 8.49	CR-275
4"	8.49	CR-40
6"	10.49	CR-60
8"	12.49	CRM-8H
10"	13.49	CRM-10H
12"	14.49	CRM-12H

NOTE: Extreme caution **MUST** be used. Be sure to wear safety glasses.

Straight Cartridge Rolls

1½" long, ⅛" hole.

Box of 50

Dia.	Grit	Jobber	Order No.
¼"	40	\$21.99	SCR-250-40
	80	21.99	SCR-250-80
	120	21.99	SCR-250-120
⅜"	40	21.99	SCR-375-40
	80	21.99	SCR-375-80
	120	29.99	SCR-375-120
½"	40	25.99	SCR-500-40
	60	24.99	SCR-500-60
	80	24.99	SCR-500-80
¾"	40	29.99	SCR-500-100
	120	25.99	SCR-500-120
	40	53.99	SCR-750-40
1"	80	53.99	SCR-750-80
	120	53.99	SCR-750-120

Straight Cartridge Rolls

1" long, ⅛" hole.

Box of 50

Dia.	Grit	Jobber	Order No.
¼"	60	\$15.99	SCR-1-250-60
	80	15.99	SCR-1-250-80
⅜"	100	15.99	SCR-1-375-100

Half-Tapered Cartridge Rolls

1½" long, ⅛" hole. Box of 50

Dia.	Grit	Jobber	Order No.
⅜"	40	\$27.99	HTR-375-40
	80	28.99	HTR-375-80
	120	26.99	HTR-375-120
½"	40	31.99	HTR-500-40
	80	29.99	HTR-500-80
	120	29.99	HTR-500-120
⅝"	40	44.99	HTR-625-40
	80	46.99	HTR-625-80

Full-Tapered Cartridge Rolls

1½" long, ⅛" hole. Box of 50

Dia.	Grit	Jobber	Order No.
⅜"	40	\$22.99	FTR-375-40
	80	22.99	FTR-375-80
	120	31.99	FTR-375-120
½"	40	27.99	FTR-500-40
	60	26.99	FTR-500-60
	80	27.99	FTR-500-80
¾"	40	27.99	FTR-500-100
	100	27.99	FTR-500-100
	120	26.99	FTR-500-120
⅝"	40	33.99	FTR-625-40
	80	33.99	FTR-625-80

Replaceable Roll Lock Discs and Holders

10 per pack

Dia.	Jobber	Order No.
2"	Medium	\$ 9.99
	Coarse	11.99
3"	Medium	15.99
	Coarse	19.99

Disc Holder

Dia.	Jobber	Order No.
2"	\$16.99	RLH-2
3"	18.99	RLH-3

Cross Buff® / Flap Wheel

Mandrel	Jobber	Order No.
4" Mandrel	\$13.79	CB-MANDREL
Set Screw (3)	6.99	CB-SCREW

Cross Buffs®

Box of 10

Dia.	Grit	Jobber	Order No.
¾"	V. Fine	\$17.99	CB-75VF
	Med.	16.99	CB-75M
1"	V. Fine	13.99	CB-1VF
	Med.	13.99	CB-1M
1½"	V. Fine	24.99	CB-15VF
	Med.	22.99	CB-15M

3-Ply

1¼"	V. Fine	\$26.99	CB-125VF-HD
	Med.	26.99	CB-125M-HD
1½"	V. Fine	24.99	CB-15VF-HD
	Med.	27.99	CB-15M-HD

Abrasive Flapwheels

1" wide, ¼" x 20 threaded. 1 each.

Dia.	Grit	Jobber	Order No.
1½"	80	\$11.99	APK-7
2"	80	11.99	APK-8
2½"	80	11.99	APK-9
1"	120	7.99	AFW-1-120
2"	120	8.99	AFW-2-120
3"	120	9.99	AFW-3-120

Mirrored Safety Glasses

Order No. PGL-21

Jobber \$4.99



NOTE: Extreme caution **must** be used when porting & polishing. Be sure to wear safety glasses.

Professional Porting & Polishing Tools



35 Pc. Porting & Polishing Abrasives Kit

A great starter kit! This kit includes a sampling of our most popular abrasives including abrasive rolls (spiral and straight), flap wheels, mounted abrasive points, abrasive roll material, mandrels and instructions.

Description	Jobber	Order No.
35 Piece Abrasive Kit	\$59.99	APK-100
Replacement Abrasives	Grit	Qty.
Full-Taper Spiral Roll, 1/2" x 1 1/2" x 1/8"	80 50	\$42.99 APK-1 x
Full-Taper Spiral Roll, 3/8" x 2" x 1/8"	80 50	59.99 APK-2 x
Cartridge Roll, 5/8" x 1 1/2" x 1/8"	80 50	59.99 APK-3 x
Flap Wheel, 1" x 1" x 1/4"	120 5	34.99 APK-4 x
Mounted Wheel, 1/4" shank	60 1	8.99 GM-12 x
Roll Mandrel, 1/4" dia., 4" long	1	8.49 CR-40 x
Flap Wheel Mandrel, 1/4" x 4"	1	13.79 CB-MANDREL x
Slotted Butterfly Mandrel 3"	1	5.99 CR-30 x

Silicon-Carbide Abrasive Rolls with Integral 4" Mandrels

- 4" integral mandrel and solid abrasive core allows you to use up the entire roll before replacing it
- Available in 1/2" and 3/8" diameters • 5 per pack

Dia.	Grit	Jobber	Order No.	Dia.	Grit	Jobber	Order No.
1/2"	60	\$15.99	LSCR-500-60	3/8" dia.	60	\$14.99	LSCR-625-60
	80	14.99	LSCR-500-80		80	21.99	LSCR-625-80
	100	16.99	LSCR-500-100				
	120	21.99	LSCR-500-120				

Port Reshaping Kit

- Superior formula uses 2-part epoxy • Dries without shrinking
- Can be milled and machined
- Withstands temperatures up to 500°F/ 260°C • Kit includes epoxy, gloves and mixing sticks
- Yields 16 oz./453.6g of material
- Order No. **PRK-99**
Jobber \$36.99



Deluxe Porting Kit

- Complete kit includes:
2 flapwheels, 4 Cross Buffs®,
7 Full Tapered Cartridge Rolls,
7 Half-Tapered Cartridge Rolls,
21 Straight Cartridge Rolls,
2 Mounted Points,
2 Cartridge Mandrels and
1 Cross Buff® Mandrel with set screws
- Includes plastic storage case
- Order No. **DPK-100**
Jobber \$69.99



Small Engine Porting Kit

- Complete kit includes:
12 straight cartridge rolls,
8 full tapered cartridge rolls,
4 half-tapered cartridge rolls,
8 Cross Buffs®, 2 abrasive rolls,
2 flapwheels, 1 Cross Buff®
mandrel with 2 set screws and
2 roll mandrels
- Includes plastic storage case
- Order No. **SEPK-5**
Jobber \$53.99

Quick Change Mandrels & Abrasive Sleeves

- 5 sleeves per pack • 1" x 1"
- Mandrel has 1/4" shaft



Description	Grit	Jobber	Order No.
Mandrel		\$11.99	GMS-101
Sleeves	40	8.99	GMS-140
	60	8.99	GMS-160

110V Electric Die Grinder

- 110V • 2.5 amp • 25,000 RPM
- 1/4" collet • 8' cord • Includes 2 collet wrenches
- Optional Speed Control lets you vary from 200 to 25,000 RPM • 6' cord • 110V • 15 amp

Description	Jobber	Order No.
25,000 RPM Die Grinder	\$209.99	GEO-600
Variable Speed Control	47.99	GEO-SC

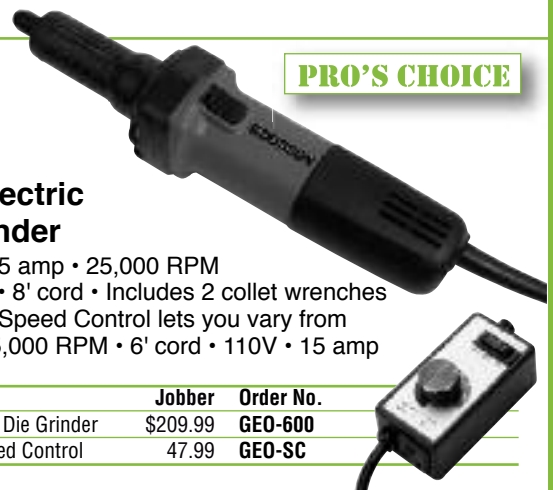

PRO'S CHOICE

CYLINDER HEAD REBUILDING
CLEANING, ASSEMBLY & SAFETY
SHORT BLOCK REBUILDING
FLYWHEEL GRINDING
CRANKSHAFT/ BRAKE & ALIGNMENT TOOLS
MEASURING TOOLS
OFFROAD BIKE, ATV HARD PARTS
V-TWIN HARD PARTS



1/4" Shank Carbide Rotary Double Cut Files

	Dia.	Length	Shank	Jobber	Order No.	Incl.
Carbide Set				\$369.99	FRDC-15-C	▼
A	1/2"	1 5/16"	1.4"	29.99	FR-10-C	x
B	1/2"	1 1/8"	1.1"	55.99	FR-34-C	x
C	1/2"	1 1/2"	1.5"	39.99	FR-55-C	x
D	1/4"	1"	1.0"	39.99	FR-45-C	x
E	5/8"	1 1/8"	1.5"	55.99	FR-46-C	x
F	3/4"	1 1/4"	1.5"	68.99	FR-44-C	x
G	3/8"	1"	1.6"	55.99	FR-65-C	x
H	3/4"	1 1/8"	1.5"	55.99	FR-75-C	x
I	5/8"	1"	1.5"	55.99	FR-93-C	x
J	1/4"	3/4"	1.3"	39.99	FR-105-C	x
K	3/8"	2 7/32"	1.3"	49.99	FR-121-C	x
L	1/2"	1 1/8"	1.4"	49.99	FR-141-C	x

Short Long



Open Fluted Rotary Files for Aluminum

Choose between 2 shank lengths – 1 1/2" and 6" in several sizes. All of the files feature a 1/4" diameter shank

	Dia.	Length	Jobber	Order No.	Incl.
1 1/2" Long Shank Kit			\$169.99	AFR-KIT	▼
A	1/2"	1"	49.99	AFR-34	x
B	1/4"	1 5/16"	49.99	AFR-45	x
C	1/2"	1 1/2"	49.99	AFR-55	x
D	1/2"	1"	49.99	AFR-93	x
E	3/8"	1 3/16"	49.99	AFR-121	x

	Dia.	Length	Jobber	Order No.	Incl.
6" Long Shank Kit			\$279.99	LAFR-KIT	▼
A	1/2"	1"	66.99	LAFR-34	x
B	3/8"	3/4"	43.99	LAFR-45	x
C	1/2"	7/16"	49.99	LAFR-55	x
D	1/2"	7/8"	66.99	LAFR-70	x
E	1/2"	1"	61.99	LAFR-93	x
F	3/8"	1 1/16"	82.99	LAFR-121	x

Order 5 or more Rotary Files, Burrs or Mounted Points (mix & match) and save 10% off jobber

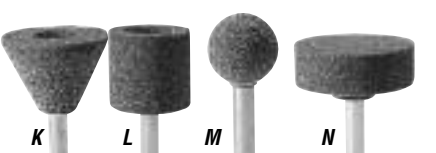
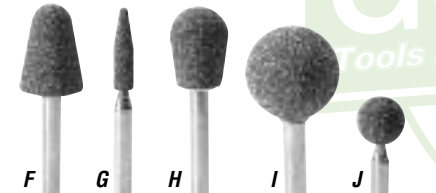
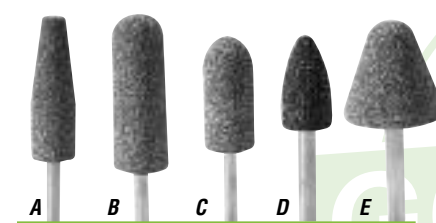

1/4" Shank Mounted Points

- Aluminum-Oxide abrasive is ideal for roughing cast iron
- 1.5" shank length

	Dia.	Length	Grit	Jobber	Order No.
A	3/4"	2 1/2"	60	\$13.79	GM-1
B	7/8"	2 3/4"	60	13.79	GM-3
C	7/8"	1"	60	10.49	GM-11
D	1 1/16"	1 1/4"	60	8.99	GM-12
E	1 1/4"	1 1/4"	60	10.49	GM-4
F	3/4"	1 1/8"	60	9.49	GM-5
G	1/4"	1 1/16"	60	8.49	GM-15
H	3/4"	1"	60	8.49	GM-23
I	1"	1"	60	8.49	GM-25
J	5/8"	5/8"	60	8.49	GM-26
K	1 3/8"	1"	60	11.49	GM-31
L	1"	1"	60	8.49	GM-38
M	3/4"	3/4"	40	8.49	GM-40
N	1 1/2"	1 1/16"	60	8.49	GM-236

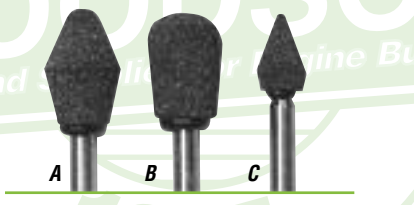

1/4" Shank Mounted Points

- Green silicon-carbide abrasive, recommended for cast iron
- Choose from 3" and 6" shanks in 6 shapes

	Dia.	Length	Grit	Shank	Jobber	Order No.
Complete Kit (12 pc. set)					\$52.99	GGM-12-KIT ▼
A	3/4"	1 1/8"	60	3"	8.49	GGM-6-3 x
	3/4"	1 1/8"	60	6"	8.49	GGM-6-6 x
B	3/4"	1"	60	3"	8.49	GGM-23-3 x
	3/4"	1"	60	6"	8.49	GGM-23-6 x
C	7/16"	3/4"	80	3"	8.49	GGM-51-3 x
	7/16"	3/4"	80	6"	8.49	GGM-51-6 x
D	3/8"	3/4"	80	3"	8.49	GGM-50-3 x
	3/8"	3/4"	80	6"	8.49	GGM-50-6 x
E	1/2"	5/8"	80	3"	8.49	GGM-111-3 x
	1/2"	5/8"	80	6"	8.49	GGM-111-6 x
F	3/8"	1/2"	80	3"	8.49	GGM-112-3 x
	3/8"	1/2"	80	6"	8.49	GGM-112-6 x

6" Long Shank Double Cut Carbide Rotary Files

	Dia.	Length	Jobber	Order No.	Incl.
Complete 5 Pc. Kit			\$179.99	LFR-KIT	▼
A	1/2"	1 1/8"	58.99	LFR-34C	x
B	1/2"	1 1/2"	39.99	LFR-45C	x
C	1/2"	1 1/2"	39.99	LFR-55C	x
D	1/2"	1 1/8"	58.99	LFR-46C	x
E	1/2"	1 3/16"	58.99	LFR-141C	x

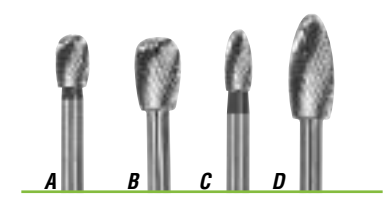

1/4" Shank Carbide Single Cut Rotary Files

	Cut Dia.	Cut Lgth.	Shank Lgth.	Jobber	Order No.
A	3/8"	5/8"	3"	\$21.99	FR-23-3-C
	3/8"	5/8"	5"	24.99	FR-23-5-C
B	1/2"	7/8"	3"	28.99	FR-33-3-C
	1/2"	7/8"	5"	32.99	FR-33-5-C
C	5/16"	3/4"	3"	24.99	FR-60-3-C
	5/16"	3/4"	5"	28.99	FR-60-5-C
D	1/2"	1 1/4"	3"	37.99	FR-65-3-C
	1/2"	1 1/4"	5"	44.99	FR-65-5-C

Mounted Points and Rotary Files

Carbide Single Cut Rotary Files for Aluminum

- 1/8" heat treated steel shanks
- For all non-ferrous metals
- 1 1/2" shank length (nominal)

Dia.	Cut Length	Jobber	Order No.
1/4"	1/2"	\$16.99	FRA-51F
1/4"	1/2"	16.99	FRA-51C
1/4"	1/2"	16.99	FRA-51A
1/4"	1/4"	16.99	FRA-51E



1/4" Carbide Rotary Files

- Cryogenically treated • Nose design reduces back-gouging
- 1/4" shank • Shanks 4" long except MRT-56C at 6" long

Dia.	Lgth	Jobber	Order No.	Dia.	Lgth	Jobber	Order No.
A .375"	1.000"	\$39.99	MSH-34C	F .500"	1.000"	\$58.99	MRT-56C
B .437"	.970"	74.99	MFM-44C	G .500"	.880"	43.99	MSE-54C
C .437"	.970"	54.99	MRT-44C	H .500"	1.000"	43.99	MSF-54C
D .437"	.875"	42.99	MSE-44C	I .500"	1.245"	47.99	MSH-54C
E .500"	.975"	54.99	MRT-54C	MFM-44C for aluminum cutting only			



1/4" Long Shank Double Cut Carbide Burr Set

- 1/8" diameter shank
- Includes custom wooden storage case and 9 burrs
- 1/4" burrs on 1/8" heat treated steel 1 1/4" long shanks



Cut Dia.	Cut Length	Jobber	Order No.	Incl.
Complete 9 Pc. Kit with Case		\$109.99	FR-9KIT	▼
A 1/4"	1/2"	12.99	FR-51A	x
B 1/4"	1/4"	12.99	FR-51B	x
C 1/4"	1/2"	14.99	FR-51C	x
D 1/4"	1/4"	12.99	FR-51D	x
E 1/4"	3/8"	12.99	FR-51E	x
F 1/4"	1/2"	12.99	FR-51F	x
G 1/4"	1/2"	14.99	FR-51G	x
M 1/4"	1/2"	12.99	FR-51M	x
N 1/4"	1/4"	12.99	FR-51N	x

Head Holders

Economy

- Holds head with either side up
- Tapered pins fit any size head bolt • Two piece set
- All steel construction
- Order No. **HH-100-G** Jobber \$24.99

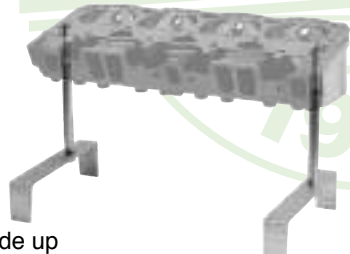

Ultra-Sturdy

- 360° stand holds head securely
- Tie-rod to prevent tipping
- Slip-resistant neoprene covered rails
- Fits domestic, foreign, truck & motorcycle heads • 3-piece set
- Order No. **HH-450** Jobber \$99.99

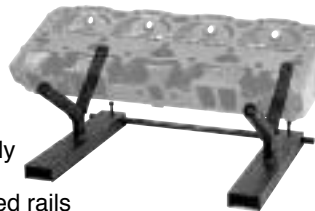

Universal

- Lightweight aluminum construction
- Slip-resistant neoprene covered rails
- Requires no bolts, clamps or adaptors
- 2 piece set • Order No. **HH-200** Jobber \$104.99

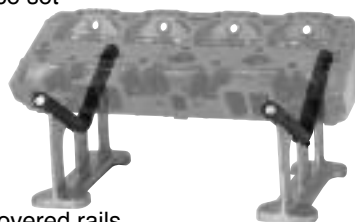

360° Swivel / 90° Sweep Vise Hold Heads in Almost Any Position

- Bolts securely to your bench or virtually anywhere
- Includes 12mm Mandrel, other sizes also available
- Optional spanner wrench tightens the base securely
- For Porting and Polishing only



Description	Jobber	Order No.
360° Swivel Vise	\$114.99	GSV-400
Spanner Wrench	43.99	GSV-WRENCH
Threaded Mandrel - 6" x 10mm	29.99	GSV-10
Threaded Mandrel - 6" x 12mm	29.99	GSV-12
Threaded Mandrel - 6" x 14mm	29.99	GSV-14

Harley® Head Plate and Head Stand

- Fits Shovel, Evolution, Twin-Cam, V-Rod, Sportster and Pan heads
- Rigid enough for cutting and installing guides and seats
- Adjustable positive stops for leveling and machining
- Use on seat and guide machine and/or head resurfacer
- Includes 2 risers • Instructions include easy-to-read diagrams for mounting Harley® heads

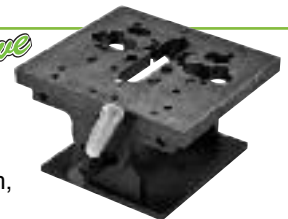

Description	Jobber	Order No.	Incl.
Complete Unit	\$799.99	HHS-600	▼
Head Stand	449.99	HHS-601	x
Head Plate	429.99	HHP-6	x

Double Harley Head Plate Available on p. 136

same day shipping

CYLINDER HEAD REBUILDING

CLEANING, ASSEMBLY & SAFETY

SHORT BLOCK REBUILDING

FLYWHEEL GRINDING

CRANKSHAFT/ BRAKE & ALIGNMENT TOOLS

MEASURING TOOLS

OFFROAD BIKE, ATV HARD PARTS

V-TWIN HARD PARTS



GBC-4 GBC-6 GBC-10 GBC-14 NH-16 NH-26 ANH-16 ANH-26

End Brushes 1/4" shank

Dia. / Wire gauge / Type	Jobber	Order No.
Standard Duty		
1/2" .020" crimped	\$7.29	GBC-4
3/4" .020" crimped	9.29	GBC-6
1" .020" crimped	11.49	GBC-10
1 1/2" .020" crimped	11.79	GBC-14
1 3/4" .012" crimped	11.49	NH-16
2 3/4" .012" crimped	14.99	NH-26
1 3/4" .014" galv. for alum.	10.79	ANH-16
2 3/4" .014" galv. for alum.	12.99	ANH-26
Ultra Duty		
1/2" .014" crimped	\$7.29	GBC-4A
1 1/8" .020" knotted	13.99	GBC-12
1 1/8" .020" knotted	14.99	GBC-12HD
3/4" .020" knotted	10.99	NH-6

Buy 5 or more, 10% off, 15 or more, 15% off jobber



1/4" Shank Brushes

Deep Well End Brush as brush wears cut back to expose new wire				
Dia.	Wire Gauge	Grade	Jobber	Order No.
1/4"	.012", 6" long	Economy	\$13.49	DEB-1
3/8"	.017", 6" long	Economy	14.49	DEB-2
Flare Brush use to remove carbon from engine ports				
1/2" ball,	5/16" cable	Ultra-duty	\$39.99	DEB-3
Port Brush as brush wears cut back spring for new wire				
1/4"	.014", 4" long	Standard	\$19.79	DEB-4
1/2"	.020", 2 1/2" long	Ultra-duty	19.79	DEB-5
Cup Brush 5/8"-11 NC				
3"	.014" twisted	Ultra-duty	\$25.79	WCB-30
4"	.014" twisted	Ultra-duty	30.29	WCB-40

CYLINDER HEAD REBUILDING

CLEANING, ASSEMBLY & SAFETY

SHORT BLOCK REBUILDING

CRANKSHAFT/ FLYWHEEL GRINDING

BRAKE & ALIGNMENT TOOLS

MEASURING TOOLS

OFFROAD BIKE, ATV HARD PARTS

V-TWIN HARD PARTS

Engine Prep Brushes

Application	Jobber	Order No.
For small feed hole in block		
1/4" x 2" x 10", nylon	\$5.29	OB-1
For cams		
5/16" x 2 1/2" x 12", nylon	5.29	OB-2
Like OB-2 but more flexible		
5/16" x 2 1/2" x 12", nylon	5.49	OB-2A
For oil return lines		
3/8" x 2 1/2" x 12", nylon	5.49	OB-3
For diesel injector		
1 3/4" brush, stainless	7.49	DIB-1
For lifter bores		
1" x 3" x 14", nylon	8.29	LBB-100

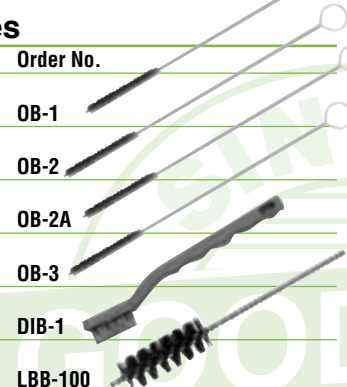

Bore Washing Brushes

Dia.	Length	Jobber	Order No.
2"	36"	\$17.79	CBB-200
2 1/4"	36"	20.79	CBB-225
2 1/2"	36"	21.79	CBB-250
2 3/4"	18 1/2"	21.79	CWB-27W
3 1/2"	18 1/2"	21.79	CWB-35
4"	18 1/2"	21.79	CWB-40
4 1/2"	18 1/2"	23.79	CWB-45
5"	18 1/2"	25.99	CWB-50

Flow Through Parts Washing Brush

- 24" long hose slides over discharge nozzle on parts washer
- Order No. PWB-FLO-1 Jobber \$21.79



Oil Gallery Brushes

Steel Wire		Jobber	Order No.	incl.
3-pc. Kit				
Size	Length	\$16.99	OGB-SK	▼
1/4" x 3"	24"	7.49	OGB-1	x
3/8" x 3"	24"	8.79	OGB-2	x
5/8" x 3"	24"	9.79	OGB-3	x
Nylon Bristle				
5-pc. Kit				
Size	Length	\$22.99	OGB-KIT	▼
3/8" x 3"	34"	6.29	OGB-38	x
1/2" x 2 1/2"	34"	6.29	OGB-42	x
5/8" x 3"	34"	6.29	OGB-5	x
3/4" x 3"	34"	7.29	OGB-7	x
3/4" x 3"	40"	8.79	OGB-8	x



Scratch Brush

- 4 x 19 row
- 13 3/4"/349.3mm long
- Steel bristles
- Order No. HB-49 Jobber \$7.49



Manual Guide Cleaning Brush

- OAL: 8 3/4"
- Order No. WCB-44 Jobber \$3.29



Round Fiber Parts Brush

- 11"/279.4mm long • Nylon bristles
- Wood Handle
- Order No. PCB-348 Jobber \$8.79



Protect yourself!

Shop safety ... everyone preaches it, but not everyone practices it.

Don't let yourself become complacent and wind up getting hurt. Always use safety glasses or wear a face shield. If you're using chemicals or working with heat, wear gloves to protect your skin.

Protect yourself ... we'd like to keep you around for a while.



See Page 66

Valve Guide Brushes

Size	Steel Brushes		Nylon Brushes	
	OAL	Order No.	OAL	Order No.
5/16" x 2 1/2"	9 1/2"	GVP-1	12"	GVP-1N
1 1/2" x 2 1/2"	9 1/2"	GVP-2	12"	GVP-2N
3/8" x 2 1/2"	9 1/2"	GVP-3	12"	GVP-3N
7/16" x 2 1/2"	9 1/2"	GVP-4	12"	GVP-4N
1/2" x 2 1/2"	—	—	10 1/2"	GVP-5N
9/16" x 2 1/2"	—	—	10 1/2"	GVP-6N
3mm x 1 1/4"	8"	GVP-7S	8"	GVP-7N
4mm x 1 1/4"	8"	GVP-8S	8"	GVP-8N
5mm x 1 1/4"	8"	GVP-9S	8"	GVP-9N
6mm x 1 1/4"	8"	GVP-10S	8"	GVP-10N
7mm x 1 1/4"	8"	GVP-11S	8"	GVP-11N
Jobber		\$6.29 ea.		\$6.29 ea.

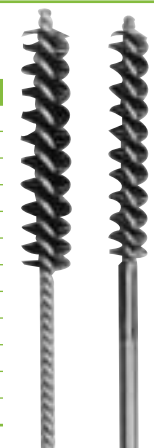

Parts Cleaning

Radial Wire Brushes

Crimped ... Standard & Heavy-Duty

This shape is specially designed to flex, giving longer life. The crimp also lets wires nestle together to support one another for more aggressive cleaning.

Twisted ... Super Duty

Tougher than crimped, strands are twisted 2/3 of the length for stiffness with flexible ends that stay tight in use. These brushes are designed to be used at higher RPMs.

Knotted ... Ultra Duty

Strands are twisted full length for best stiffness and fastest cleaning. Knots have more strands to resist breakage and outlast typical knotted brushes by a wide margin.

Radial Wire Brushes

- American made oil tempered high carbon steel wire • High density for faster cleaning and longer life • Excellent balance • 1/2"-5/8" arbor

Size	Wire	Duty	Jobber	Order No.
6"x1 3/16"	.014" Crimped	Std.	\$14.99	ADA-6
6"x1 1/8"	.014" Crimped	Heavy	39.99	DH-6
7"x7/8"	.014" Crimped	Heavy	38.99	DA-7
8"x1 1/16"	.014" Crimped	Heavy	79.99	DH-8
6"x9/16"	.016" Twisted	Super	32.29	TS-6
8"x3/4"	.016" Twisted	Super	45.79	TS-8
6"x7/16"	.023" Knotted	Ultra	27.29	QTC-6

An \$80 value
when purchased
separately



BG-KIT

Engine Rebuild Brush Kit

- Includes the brushes you'll need for an average engine job
- A great starting place, then add as needed
- Replacement brushes available

Description	Jobber	Order No.
Standard Brush Kit - 10 Pc. Kit	\$46.99	BG-KIT ▼
4" Nylon Cylinder Washing Brush	21.79	CWB-40 x
1 1/2" Nylon Valve Guide Brush	6.29	GVP-2N x
3/8" Nylon Valve Guide Brush	6.29	GVP-3N x
Lifter Bore Brush	8.29	LBB-100 x
Small Nylon Feed Hole Brush	5.29	OB-1 x
Block Oil Return Line Brush	5.29	OB-2 x
3/8" Oil Gallery Brush	6.29	OGB-38 x
1/2" Oil Gallery Brush	6.29	OGB-42 x
5/8" Oil Gallery Brush	6.29	OGB-5 x
Flow Through Parts Washing Brush	8.79	PCB-348 x

Roloc Bristle Discs

- Effective on cast iron, yet safe for aluminum
- Abrasive grains embedded in plastic bristles that break down to expose new grain

Roloc Bristle Discs

Size	Color	Grit	Max. RPM	Jobber	Order No.
2"	Green	50	25,000	\$10.49	RBD-2G
	Yellow	80	25,000	10.49	RBD-2Y
	White	120	25,000	10.49	RBD-2W
3"	Green	50	18,000	15.79	RBD-3G
	Yellow	80	18,000	15.79	RBD-3Y



Holders

Size	Description	Jobber	Order No.
2"	Roloc-Type Holder	\$15.99	RLH-2
3"	Roloc-Type Holder	17.99	RLH-3

Super Scraper™

SS-4U

- Remove gaskets, carbon, rust, paint, etc. • Precision-ground
- Solid carbide-tipped
- Double-edged blade
- Lasts longer than plain steel
- Nickel-chrome
- 1/8" thick steel shank
- For all metals including aluminum

Width	Jobber	Order No.
1 1/4"	\$28.99	SS-4U
2"	40.99	SS-4U2

SS-4U2

Pneumatic Scraper

- Faster and easier than scraping by hand
- Beveled, 1" steel blade • Removes gaskets with 2500, 3/64" strokes per minute • Resharpenable blade

Description	Jobber	Order No.
Complete Tool	\$129.99	AGS-310
Replacement Blade	12.29	AGS-310B



Keeper-Keeper

- Screws closed tightly
- 1/4" holes
- Ideal for tumbling keepers
- Solvent resistant PVC
- Order No. **VK-15**
- Jobber \$15.49

Valve Stem Protectors

- Protects against parts tumbler damage
- Slip on and off easily
- 16 per package
- Order No. **VSP-16**
- Jobber \$12.99



Glass Bead Guns, Gloves & More

CYLINDER HEAD
REBUILDING

CLEANING,
ASSEMBLY & SAFETY

SHORT BLOCK
REBUILDING

CRANKSHAFT/
FLYWHEEL GRINDING

BRAKE & ALIGNMENT
TOOLS

MEASURING
TOOLS

OFFROAD BIKE, ATV
HARD PARTS

V-TWIN
HARD PARTS

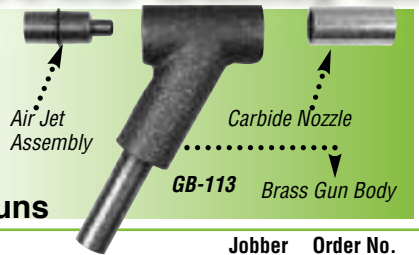

Glass Bead Guns

Description	Jobber	Order No.
Complete Gun For Smaller Machines Fits Trinco, Econoline, etc. Includes Gun Body, Nozzle and Air Jet Assembly	\$99.99	GB-113
Replacement Parts		
Gun body only	\$49.99	GB-111
Carbide nozzle 19.05mm OD, 7.94mm ID	48.99	GB-204
Air jet assembly 3.97mm ID, 25 CFM	19.99	GB-330



Complete Gun For Larger Machines		Jobber	Order No.
Fits Zero, Blast-It-All, Winona Van Norman, etc. Includes ceramic nozzle (GB-75) .313" / 7.94mm ID standard		\$128.99	GB-100
Replacement Parts			
Gun body only		\$79.29	GB-101
Barbed Brass fitting		8.49	GB-04
Nozzle holding nut (not included in kit)		14.79	GB-54
Rebuild Kits			
.250" ID		\$53.99	GB-4-OK
.313" ID		53.99	GB-5-OK
.375" ID		53.99	GB-6-OK
.437" ID		55.99	GB-7-OK
Nozzle 7/8" OD x 1 3/8"			
.250" ID		21.99	GB-74 x
.313" ID		21.99	GB-75 x
.375" ID		21.99	GB-76 x
.437" ID		21.99	GB-77 x
Replacement Orifices			
		47.99	GB-64 x
		47.99	GB-65 x
		47.99	GB-66 x
		47.99	GB-67 x
Lock Nut		8.49	GB-52 x x x x
O-Ring		6.29	GB-53 x x x x

Trigger-Control Glass Bead Gun

- Uses 9 CFM of compressed air
- Replacement gun • For most economy bench-top glass bead cabinets
- Gun includes replaceable ceramic nozzle
- Nozzle diameter: 3/16" (4.76mm)
- Fits most cabinets with 1/2" (12.7mm) ID media supply line, threaded for 1/4" (6.35mm) air line fitting



Description	Jobber	Order No.
Trigger-Control Glass Bead Gun	\$98.29	GB-9
Replacement Nozzles (3 pack)	40.49	GB-9-NOZ



Glass Bead Gloves

- 30" overall length • For ports up to 10" diameter
- Durable cloth-lined Neoprene glove with nylon sleeve
- Sleeve design makes attaching glove to your machine, faster and easier • Clamp sold separately

Port Size	Description	Jobber	Order No.
Up to 8" (20.32 cm)	Single: left-hand glove	\$36.99	GB-654-G
	Single: right-hand glove	36.99	GB-655-G
	Pair: one right-hand & one left-hand	59.99	GB-660-G
Up to 10" (25.4 cm)	Pair: one right-hand, two left-hand	79.99	GB-663-G
	Single: left-hand glove	48.99	GB-754-G
	Single: right-hand glove	48.99	GB-755-G
Pair: one right-hand & one left-hand		78.99	GB-770-G
8" and 10"	Replacement Clamp: fits both port sizes	7.79	GB-CLAMP

Glass Beads

- Clean parts thoroughly without removing material
- 50 lb. bag • Size #8
- Safe for ferrous & non-ferrous materials
- Order No. **GB-CM**
Jobber \$49.99



Glass Bead Cabinet Window Film

- Protects the inside of glass bead cabinet windows
- Save time and money – replace the film rather than the glass • 24" x 10' roll
- Order No. **GB-FILM**
Jobber \$17.99



Tech Tip For best results, attach to cabinet window with ordinary double-faced tape (not included)

Hydro-Air Guns

- Hold the BG-150 by the air supply hose
- The grip stays cool even when spraying hot water • BG-100 Trigger Action gun uses water and air pressure to deliver a powerful stream of "cold steam"
- BG-100 includes siphon tube, extension nozzle & flushing adaptor and connects to openings 3/4" to 1 1/2" in diameter

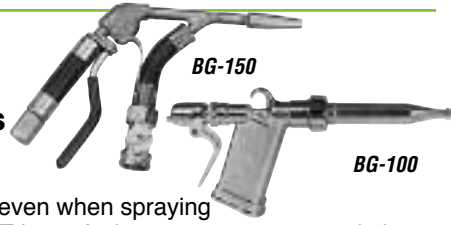

Description	Jobber	Order No.
Hydro-Air Gun	\$89.99	BG-150
Trigger-Action Hydro-Air Gun	113.99	BG-100
Replacement Nozzle for BG-100	27.99	BG-NOZZLE

Tumbler Media & Parts

Cleaning Media

For Part Tumblers



Ceramic Diagonals (20 lb.)
For soft materials such as brass and aluminum. $\frac{5}{16}$ " dia., $\frac{5}{8}$ " long
Order No. **PTM-20CR** \$67.99



Steel Ballcones (20 lb.)
For Springs. .385" ball in .475" cone
Order No. **PTM-20BC** \$139.99



Steel Diagonals (20 lb.)
For valves. $\frac{3}{8}$ " dia., $\frac{3}{8}$ " long
Order No. **PTM-20D** \$139.99

For Airless Blasters

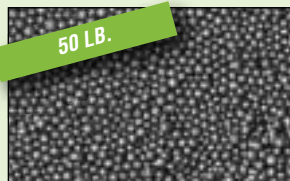

Steel Shot, 170 grade (50 lb.)
Diameter varies from .017" to .024".
Order No. **SS-CM** \$47.99

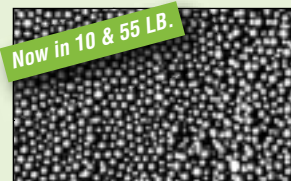

Stainless Steel Shot, Conditioned.
Clean aluminum heads to look like new. Restores bright aluminum finish. Lasts longer than plain carbon steel shot. Diameter varies from .006" to .016".
55 lb. Order No. **SS-CS** \$309.99
10 lb. Order No. **SS-CS10** \$69.99

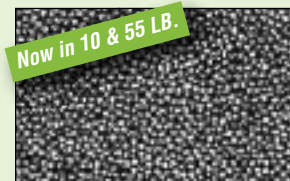

Stainless Steel Cut Wire Shot
Unconditioned. Clean cast iron or aluminum heads before and normalize after welding. Helps prevent surface corrosion after blasting. Diameter is .020".
55 lb. Order No. **SS-CW** \$489.99
10 lb. Order No. **SS-CW10** \$109.99



The more you buy, the more you save!

Order 6 or more pairs of HTG gloves (any combination) & save 10% off jobber!

Hot Tank Gloves

- Not for solvent use
- Sold in pairs • Shoulder length features eyelets & strings at tops to prevent slipping

Description	Jobber	Order No.
Elbow Length (18 1/2" long)	\$33.79	HTG-200E
Shoulder Length (34 1/2" long)	41.99	HTG-200L



Mirrored Safety Glasses

- Wrap-around design provides protection against moderate impact hazards such as metal chips, sparks and particles
- Tinted lenses provide sun glare protection only • Universal bridge • Polycarbonate lenses • Do not use as welders helpers
- Order No. **PGL-21** Jobber \$4.99



Full Length Neoprene Shop Apron

- Protects from caustics, steam, grease and oil
- Bib-style • 35" x 45"
- Order No. **HTA-300**
Jobber \$35.79

Shown with Shoulder Length Hot Tank Gloves (above)



Cloth Shop Apron

- Bib-style apron
- Heavy duty black fabric
- Several handy pockets
- Features an embroidered Goodson Racing logo
- Machine Washable
- Order No. **CA-100**
Jobber \$19.99



Parts Tumbler Solution

- Dilute 30:1 with water
- For best results, dry parts with compressed air • 1 gallon
- Order No. **PT-SOL**
Jobber \$12.99



Parts Tumbler Rebuild Kit For Sioux™ 710 Parts Tumbler

- Replaces discontinued Sioux™ parts

Description	Jobber	Order No.
Rebuild Kit	\$178.49	SX-710-KIT
Small Steel Gear	49.99	271
Fiber Gear	48.29	19275



Parts Tumbler Basket

- Fits Goodson, K.I., Axe, RMC, and Peterson
- 8" x 12" x 12"
- Order No. **PT-BASKET**
Jobber \$269.99

Parts Tumbler Flexible Rubber Coupler

- Fits Goodson, K.I., Axe, RMC, and Peterson
- Order No. **PT-COUPLER**
Jobber \$27.29



CYLINDER HEAD
REBUILDING

CLEANING,
ASSEMBLY & SAFETY

SHORT BLOCK
REBUILDING

CRANKSHAFT/
FLYWHEEL GRINDING

BRAKE & ALIGNMENT
TOOLS

MEASURING
TOOLS

OFFROAD BIKE, ATV
HARD PARTS

V-TWIN
HARD PARTS

Order 6 or more cans
(any combination),
save 10% off jobber



Rust Shield

Short-term

- Non-sticky
- Lasts several weeks
- Wipes off with just a towel

Long-term

- Formula is thicker and protects much longer but requires a solvent to remove

Formula	Jobber	Order No.
Short Term	\$12.99	RS-16
Long Term	16.79	RS-16-0D



Need a larger quantity?
Call for information.

Cosmoline®

- Brush directly from can onto freshly-machined engine components
- Protects iron, steel and aluminum • Soften with mineral oil to dip small parts • 2 lb. can
- Order No. **RPC-2A** Jobber \$27.99



Rust Proofing Oil

- Apply full strength • Creates a protective film • Washes off with standard solvents
- Brush or spray on using the Sure Shot Sprayer (below)
- 1 Gallon / 3.78 L
- Order No. **RPO-10** Jobber \$72.99



Rust Shield for Shop Equipment

- Stops rust without causing rancidity • Mixes with coolant – no need to remove it before using the machine • 1 Gallon / 3.78 L
- Order No. **RS-128** Jobber \$25.99

Nickel-Chrome Plated Brass Sure Shot® Sprayer

- 32 ounce capacity • Apply rust proofing compounds easily
- Pressurize it with shop air – 80-150 psi
- No hoses or cords to limit movement
- Nickel Chrome plated brass • Spray nozzle adjusts from stream to spray • Can be used with most oil, solvent and water based materials • Not recommended for paint

Description	Jobber	Order No.
Sure Shot Sprayer	\$99.99	PS-2002
Replacement Nozzle Assembly	10.99	PS-2002NZ
Replacement Filler Cap	11.99	PS-2002FC
Replacement Valve	8.29	PS-2002V



Adjustable Coolant Hoses

- Universal hoses hold any shape
- Ideal for all crankgrinders, honing machines, flywheel grinders and surface grinding machines
- Make any length
- Unharmful by chemicals

Complete Kits (all hoses are 18" long)

Description	Jobber	Order No.
1/4" ID, 1/8" NPT, 1/4" round nozzle	\$16.99	ACH-400
Fits most parts washers, wet-type seat grinders, and valve refacers		
1/2" ID, 3/8" NPT, 3/8" round nozzle	17.99	ACH-600
Fits most cylinder hones and flywheel grinders		
1/2" ID, 1/2" NPT, 1/2" round nozzle	19.99	ACH-800
Fits most crankshaft grinders and camshaft grinders		

Flare Nozzles & Other Parts

Description	Jobber	Order No.
1" flare nozzle for 1/4" hoses	\$7.99	ACH-407
1 1/4" flare nozzle for 1/2" hoses	8.99	ACH-807
2 1/2" flare nozzle for 1/2" hoses	9.99	ACH-809
1/4" ID hose, 11" long	11.99	ACH-401
1/2" ID hose, 11" long	11.99	ACH-801
1/4" NPT connector for 1/4" ID	6.99	ACH-406
3/8" NPT connector for 1/2" ID	6.99	ACH-804
1/2" NPT connector for 1/2" ID	6.99	ACH-805

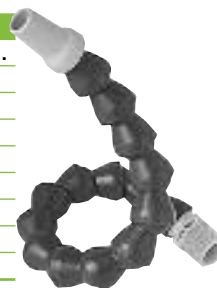

Sludge Filter Bag

- Fits any machine with a coolant sump
- Replace costly OE filters with this economical, universal sock
- Add filtration to machines that don't have enough • 8" x 24" polyester knit sock
- Order No. **SB-1** Jobber \$8.99



Coolant Pumps

170 Gal. Per Hour Pump

- HP: 1/125
- Capacity: 170 gal/hr. at 1" depth • Viton Seals
- Voltage: 115
- Size: 4" x 3 1/4" x 2 3/4"
- Order No. **COP-166** Jobber \$104.79



1200 Gal. Per Hour Pump

- HP: 1/6
- Capacity: 1200 gal/hr. at 1" depth
- Voltage: 115
- Size: 7 3/4" x 6 1/16" x 4 5/16"
- Order No. **COP-1833** Jobber \$144.79



Universal Coolant Magnet

- Ideal for Honing Tanks, Flywheel Grinders, Crankshaft Grinders, Head Surfacers and more
- Prevents metal swarf from passing into the coolant tank
- Cut or shape to fit machine bases and return ways
- Measures 3"x48"
- Order No. **UCM-348** Jobber \$23.99



CYLINDER HEAD REBUILDING

CLEANING, ASSEMBLY & SAFETY

SHORT BLOCK REBUILDING

CRANKSHAFT/ FLYWHEEL GRINDING

BRAKE & ALIGNMENT TOOLS

MEASURING TOOLS

OFFROAD BIKE, ATV HARD PARTS

V-TWIN HARD PARTS

Cleaning Solutions



Defoaming Agent Stops Foaming In Solvents And Coolants

- For jet washers, air-agitated hot tanks and coolant sumps
- Highly concentrated – start with 1 ounce in 50 gallons

Size	Jobber	Order No.
8 oz. / 236.6mL	\$10.99	D-FOAM-10
1 gallon / 3.79 L	32.99	D-FOAM-128



Microbiostat Controls Bacteria & Fungus In Coolant Reservoirs

- Treat at 1 oz. per 5 gallons of capacity
- Operate machine for 30 minutes then empty the reservoir
- Refill with coolant and treat 1 oz. per 10 gallons
- Re-treat every 10 days to 2 weeks as needed to prevent reoccurrence
- 20 oz. bottle
- Order No. **GBP-20** Jobber \$32.79

Pro Jet Spray Cleaning Powder

- Heavy-duty • Non-caustic
- Penetrates to emulsify encrusted dirt, grease and oil on cast iron & aluminum
- Won't foam excessively
- Additives prevent scale build-up in jet spray components
- Use to maximum 165° F / 73.9° C
- Mix ratio: 4 oz. per gallon of water
- 50 lb. / 22.68 kg pail
- Order No. **PJS-50** Jobber \$99.99



Medium Duty Ultrasonic Detergent with Rust Preventative

- Biodegradable
- Safe to handle and use
- Safe to use with ferrous, aluminum, most soft metals and plastics
- In-process rust preventative
- Exceptional ultrasonic cleaning at all temperatures
- 5 gallons • Order No. **USD-MD50** Jobber \$109.99



Concentrated Detergents For Hot Tank or Jet Wash

For Ferrous Parts

- Strong alkaline • Removes dirt, heavy oil & grease, carbon, light rust & paint
- 25 lbs. • Mix ½ lb. to 1 gal.
- Order No. **D-CI25** Jobber \$99.99

For Non-Ferrous Parts

- Safe on aluminum & sensitive metals, rubber & plastic parts
- Removes heavy grease & oil • 50 lb. pail • Mix ratio: ¼ lb. to 1 gal. • Order No. **D-AL50** Jobber \$129.29



Heavy Duty Ultrasonic Detergent

- For ultrasonic immersion tanks
- Safe to use with ferrous metals and aluminum
- Exceptional ultrasonic cleaning
- Excellent buffing & polishing compound remover
- 5 gallons
- Order No. **USD-HD50** Jobber \$109.99



pH Test Strips Ensure Chemicals Are Working At Peak Efficiency

- Easy to use • 100 tests per package
- Use the handy guide on the box to determine pH between 0 and 14
- Order No. **HT-PH** Jobber \$29.99



Tech Tip

Pay attention to the mix ratio on cleaning products!
 It's important that you start mixing on the weak side and work your way up. An overly strong concentration is just as ineffective as an overly weak mixture. By starting out weak, you can always add to the concentration, but it's difficult to dilute the mixture without starting over completely. Use pH Test Strips to check the concentration.

Replacement Cartridge Filters

- For most ultrasonic cleaning machines
- 2 7/8" dia. x 9" long

Filtration	Jobber	Order No.
30 microns	\$13.99	USF-30
50 microns	13.99	USF-50



CYLINDER HEAD
REBUILDING

CLEANING,
ASSEMBLY & SAFETY

SHORT BLOCK
REBUILDING

CRANKSHAFT/
FLYWHEEL GRINDING

BRAKE & ALIGNMENT
TOOLS

MEASURING
TOOLS

OFFROAD BIKE, ATV
HARD PARTS

V-TWIN
HARD PARTS

Full Service ... FAST!



"We are committed to maintaining your privacy. Information about you and your business is never sold or given to anyone outside of our company."

- Sue, Goodson Database Manager - 26 years of service

CYLINDER HEAD
REBUILDING

CLEANING,
ASSEMBLY & SAFETY

SHORT BLOCK
REBUILDING

CRANKSHAFT/
FLYWHEEL GRINDING

BRAKE & ALIGNMENT
TOOLS

MEASURING
TOOLS

OFFROAD BIKE, ATV
HARD PARTS

V-TWIN
HARD PARTS



Organize, Clean And Store Small Parts With GOODSON Small Parts Baskets

- Galvanized, welded 1/4" mesh
- Withstands most solvents
- Lids keep parts from falling out
- Not for use in caustics

Description	Dia. (in/mm)	Long (in/mm)	Jobber	Order No.
Small Basket with Lid	2 1/2"/57.2	7"/117.8	\$10.99	PWB-2
Medium Basket with Lid	4 1/2"/114.3	7"/117.8	12.99	PWB-4
Double Basket	9"/228.6	16"/406.4	19.99	PWB-25
Single Basket only	8"/203.2	9"/228.6	12.99	PWB-10
Lid and Clip only (fits PWB-10)			8.99	PWB-10L
Single Basket with Lid	8"/203.2	9"/228.6	19.99	PWB-15
Basket Clip Only			2.99	PWB-15C

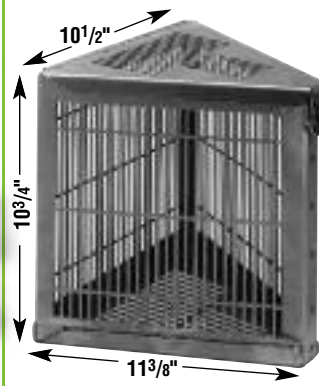

Jet Wash Parts Basket Makes a 24" Circle

- Triangle-shaped • Sit side by side on Jet Wash table • Fit more baskets in the machine to clean faster
- Order No. **JWB-6** Jobber \$103.29

Buy a set of six and save 10% off jobber

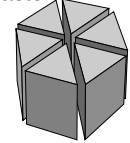

Six baskets fit in 24" diameter

Lightweight Fiberglass Face Shield

- Posi-lock headgear
- Clear lens measures 8" x 12" x .060" thick
- Replaceable lens - no need to buy the whole unit when all you need is the lens



Description	Jobber	Order No.
Complete Unit	\$24.99	PFS-30
Replacement Lens	9.99	PFS-C

Machine Washable Cotton Shop Towels

- 15"/381mm square
- Highly absorbent
- Hundreds of uses
- Color may vary



Quantity	Jobber	Order No.
5 Pack	\$ 3.99	WST-5
25 Pack	8.99	WST-25
50 Pack	16.99	WST-50

Nitrile Parts Washing Gloves Safe for use in solvents



Lined: Long-lasting Nitrile exterior. Flock lined. Won't swell. 13" long.

Size	Jobber	Order No.
Large (1 pair)	\$7.99	PWG-SOL-L
X-Large (1 pair)	9.99	PWG-SOL-XL

Unlined: Industrial quality textured Nitrile.



Size	Qty.	Jobber	Order No.
Standard (9" long)	Large	100	\$12.99 NGL-L
	X-Large	100	12.99 NGL-XL
Gauntlet (12" long)	Large	50	16.99 PNGL-L
	X-Large	50	16.99 PNGL-XL

Unlined gloves fit either hand

Disposable Lint-Free Assembly Wipes

- Snow-white
- Shows dirt easily
- Pop-up box • 9" x 17"
- Ideal for a multitude of uses at the shop, at the track, even at home!



Quantity	Jobber	Order No.
100	\$20.99	AW-100
220	YOUR BEST VALUE!	25.29 AW-250



Gauntlet Style Heat & Flame Resistant Gloves

- Heavy, lined red terrycloth
- 13 1/2" Long
- Safe to 450° F / 232.2° C
- Order No. **HR-300** Jobber \$30.49



Mirrored Safety Glasses

- Wrap-around design
- Tinted lenses provide sun glare protection
- Universal bridge
- Polycarbonate lenses
- Do not use as welders helpers
- Order No. **PGL-21** Jobber \$4.99

Parts Trays ... the more you buy, the more you save!

Order 4-9 save 10% off jobber, 10 or more save 20% off jobber
Mix or Match to make quantities



Dual Overhead Cam Cylinder Head Organizer Tray

- Store valves, springs, retainers, keepers, valve lash adjusters & camshafts
- Virtually unbreakable
- Oil and solvent resistant
- Keep valve lash adjusters from getting mixed up and changing the valve adjustment
- Order No. **DOHC-1** Jobber \$44.99

Dimensional weight & surcharges may apply

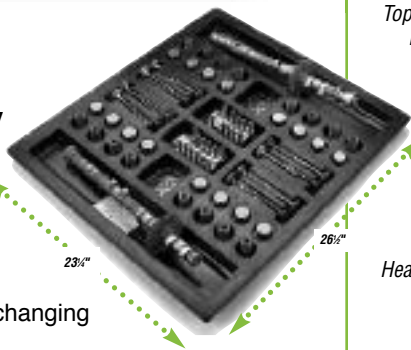

23 1/4"

26 1/2"



Stackable Cylinder Head Organizer Trays

- Store valves, springs, retainers and keepers in order for assembly • Impervious to oil and most solvents
- Order No. **SHO-8** Jobber \$54.99

Dimensional weight & surcharges may apply



Valve Train Tray For 4, 6 or 8-Cylinder OHV Engines

- Heavy duty construction and design
- Keeps push rods, rockers, lifters, etc. in order
- Unbreakable • Measures 11 1/8"W x 13 1/2"D x 1 1/2" H
- 64 compartments • Order No. **VTO-80** Jobber \$39.99

Dimensional weight & surcharges may apply

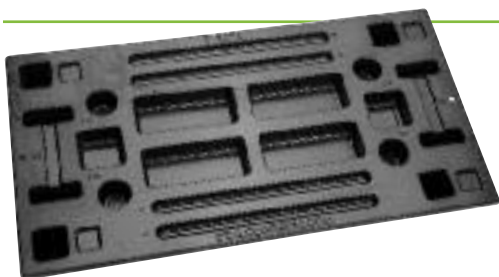

Harley® Head Organizer Tray

- Virtually unbreakable molded plastic • Oil and solvent resistant • Trays stack for easy storage
- Order No. **HHO-2** Jobber \$44.99

Dimensional weight & surcharges may apply

Parts Organization

Top tray features 1" deep lip to keep parts from rolling off

Solid steel hangers hold piston rods and crankshafts

Heavy duty casters make moving the engine and cart easy

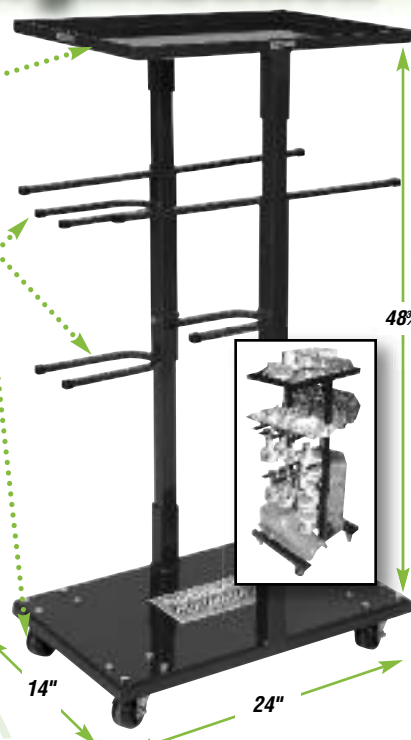

48 1/4"

14"

24"

Engine Storage Cart

- An efficient space-saver
- Heavy-duty casters
- Holds all engine parts off the floor from tear-down to reassembly in less than 4 square feet
- Move the whole engine easily
- Some assembly required
- Order No. **EC-200** Jobber \$329.99

Ford/Chevy Block Organizer Tray

- Store pistons, rods, lifters, push rods & camshafts
- Formed compartments keep engine components securely in place

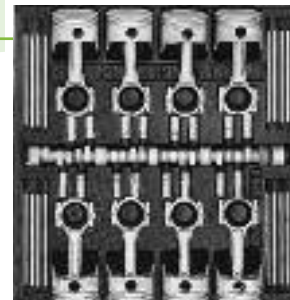

Fits	Size	Jobber	Order No.
Small Block	24 1/4"x25 1/2"x1 1/2"D	\$29.99	IE0-80
Big Block	30 1/4"x28 1/2"x1 3/4"D	36.99	IE0-90

Dimensional weight & surcharges may apply

The more you buy, the more you save!

Order 4-9 save 10% off jobber, 10 or more save 20% off jobber.
Mix & Match



Bifocal Magnifying Safety Glasses



Diopter	Jobber	Order No.	Diopter	Jobber	Order No.
1.00	\$16.99	BSG-100	2.00	\$16.99	BSG-200
1.25	16.99	BSG-125	2.25	16.99	BSG-225
1.50	16.99	BSG-150	2.50	16.99	BSG-250
1.75	16.99	BSG-175	3.00	16.99	BSG-300

CYLINDER HEAD REBUILDING

CLEANING, ASSEMBLY & SAFETY

SHORT BLOCK REBUILDING

CRANKSHAFT/ FLYWHEEL GRINDING

BRAKE & ALIGNMENT TOOLS

MEASURING TOOLS

OFFROAD BIKE, ATV HARD PARTS

V-TWIN HARD PARTS

Servicio Completo... Rápido!



"¡Hablamos español! Para su conveniencia tenemos representantes bilingües que le puedan ayudar con su orden."
- Holly, Ventas y Servicio, 3 años de servicio

Parts Tags & Marker

- Won't tear or wash off
- Tough enough to go through a jet wash or hot tank
- Heavy wire ties • Includes 2 permanent markers
- Tag dimensions: 3½"L x 5/8"W with 5/32" hole for wire tie



Description	Jobber	Order No.
1000 Parts tags, with 2 markers	\$53.99	IDT-1000
Permanent Marker only	2.99	IDT-MARKER



PSP-20



Buy 12 or more
(any combination)
and save 10% off
jobber

RSP-10

Organizer Safety Pins Keep Part Sets Together

- Parts Safety Pin** • Organize valve springs, rods, etc., from disassembly to cleaning to reassembly
- Rod & Cap Mini Pin** • Keep connecting rods & rod caps together to prevent mix-ups

Description	Jobber	Order No.
Parts Safety Pin (3/4" x 12")	\$7.99	PSP-20
Rod & Cap Mini Pin (3/4" x 4")	4.99	RSP-10



Engine & Parts Storage Bags

- Rugged, 3-mil thickness resists tearing
- Engine bags feature 4-mil thickness for extra strength
- Protects your professional work

- Waterproof • Protect finished work from damage • 4 sizes fit most common rebuilt assemblies • Jumbo engine bags are extra-strong and big enough to accommodate complete engines • Jumbo head bags fit the largest cylinder heads
- Ideal for storing heads, cranks, blocks, etc.

Size	Description	Quantity	Jobber	Order No.
8" x 4" x 20"	Piston bag	roll of 250	\$47.29	BC-8
16" x 37"	Heads, cranks, misc.	box of 100	62.99	BC-15
17" x 44"	Jumbo head bag	roll of 100	66.29	BC-17
27" x 18" x 36"	Box-style for blocks	box of 50	68.29	BE-20
44" x 52"	Jumbo engine bag	roll of 50	129.29	BE-44

Shrink Wrap

- Keep machined surfaces clean
- Easy-to-use • High-clarity film
- Protects from dirt, dust and moisture
- No need to stock several bag sizes

Size	Jobber	Order No.
5' x 100' w/ Extended Core	\$13.79	SW-5
18' x 1500' with 3" core	34.79	SW-18



Heavy Duty Steel Stamps

- For hard materials • Order in sets or individually • For a single stamp, state character desired after Order No. Example: **SCH-1/4(A)** Single Character stamp, 1/4" size, Letter "A"



Char. Size		Shank Size		Number Sets	
Char. Size	Shank Size	Jobber	Order No.	Char. Size	Shank Size
1/8"	5/16"	\$43.99	SFH-1/8	Single Characters	
3/16"	3/8"	47.99	SFH-3/16	3/16"	3/8"
1/4"	7/16"	54.99	SFH-1/4	1/4"	7/16"
3/16"	3/8"	\$8.99	SCH-3/16	Single Characters	
1/4"	7/16"	8.99	SCH-1/4	3/16"	3/8"

Special and custom orders are available, call 1-800-533-8010

Smog Plugs

Hard-to-find replacements for OE

- Replace smog plugs damaged during head cleaning process

EMP-15



EMP-34



Application	Thread	Jobber	Order No.
Chevy 2.5L, 4.1L	3/4" x 18	\$4.29	EMP-15
Ford 302, 351	5/8" x 11 (outside), 7/16" x 14 (inside)	4.29	EMP-34

CYLINDER HEAD REBUILDING
CLEANING, ASSEMBLY & SAFETY
SHORT BLOCK REBUILDING
CRANKSHAFT/FLYWHEEL GRINDING
BRAKE & ALIGNMENT TOOLS
MEASURING TOOLS
OFFROAD BIKE, ATV HARD PARTS
V-TWIN HARD PARTS

Last Blast & Hi-Temp
Last Blast



The more you buy, the more you save

Order a case of 12 and save 15% off jobber

Mix and match colors to make a case.



Last Blast Spray Paint

- Quick-dry formula lets you handle parts in minutes
- Pigment won't smudge
- Resists abrasion, corrosion and most solvents • Paint heads, blocks and parts just like OE
- **Last Blast** restores a "fresh from the bead-blaster" look to all types of cast iron
- **Aluminum Last Blast** makes aluminum heads and parts look new
- **Color Last Blast** in popular, factory colors

Color	Jobber	Order No.
Cast Iron Gray	\$6.49	LB-1
Aluminum Gray	6.49	ALB-1
Ford Gray	6.99	CLB-43
GM Black (Gloss)	6.99	CLB-58
Ford/Chrys. Red	6.99	CLB-59
Ford Blue	6.99	CLB-60
Chevy Orange	6.99	CLB-61

Hi-Temp Last Blast

- Hard, chemical-resistant finish
- Withstands continuous heat up to 1200°F/648.9°C
- Won't deteriorate like ordinary paints
- For blocks, manifolds, or any external parts subjected to high heat
- Dries tack-free in 10 min., then heat at 450°F for 1 hour to create a professional, durable finish

Color	Jobber	Order No.
Cast Iron Gray	\$7.79	LB-1-HT
Aluminum Gray	6.99	ALB-1-HT
Black (Matte)	6.99	CLB-58-HT



**Buy 5,
(any combination)
save 10%
off jobber**



Metal Markers

- No shaking needed
- Quick drying • Withstands oil, grease and surface contact • Won't lose its brilliance or legibility

Color	Order No.
Orange	MM-STD
Black	MM-010
Yellow	MM-030
White	MM-050
Green	MM-060
Red	MM-070
Blue	MM-080

Jobber \$5.29

High-Performance Hylomar® Gasket Maker & Thread Sealer



- Maintains seal integrity up to 600°F / 315.5°C
- Polyol-based compound turns from a gel into flexible putty within minutes of application • Non-hardening formula
- Impervious to oil, gasoline, glycol and other engine fluids
- Oxygen-sensor safe • Seals gaps .01" or less
- 100 gram tube • Use Solvent 184 to remove gasket and prepare dressing surface for new application
- Order No. **HBS-1** Jobber \$21.99

Solvent 184 Cleaner/Degreaser

- Use to clean machined surfaces and to prepare surfaces for application of sealants and adhesives
- Removes Hylomar® Gasket Maker
- Non-flammable
- Non-aerosol can with built-in nozzle cap to reduce waste
- 16 oz./473mL
- Order No. **HAS-16** Jobber \$19.79



2" Dispensing Pliers for Flexible Tubes

- Maximizes the usage of all the material in the tube due to its effective means of application • Dispenses even the thickest sealant through a very small opening, permitting better application control • Reduces both cleanup time and the possibility of skin contact or other problems caused by excess material squeeze-out
- Order No. **EB-416** Jobber \$19.29



CYLINDER HEAD
REBUILDING

CLEANING,
ASSEMBLY & SAFETY

SHORT BLOCK
REBUILDING

CRANKSHAFT/
FLYWHEEL GRINDING

BRAKE & ALIGNMENT
TOOLS

MEASURING
TOOLS

OFFROAD BIKE, ATV
HARD PARTS

V-TWIN
HARD PARTS

Boring Bar Cutters & Parts

CYLINDER HEAD REBUILDING
CLEANING, ASSEMBLY & SAFETY
SHORT BLOCK REBUILDING
CRANKSHAFT/ FLYWHEEL GRINDING
BRAKE & ALIGNMENT TOOLS
MEASURING TOOLS
OFFROAD BIKE, ATV HARD PARTS
V-TWIN HARD PARTS



Single-Piece (Solid) Style
Holder with integral cutting bit. Excellent cutting yet economical. Resharpenable. When no longer usable, replace entire cutter.



1-Edge Replaceable Type
Tool holder with separate bit. Excellent cutting yet economical. Resharpen the cutter bit many times. When no longer usable, replace only the bit.

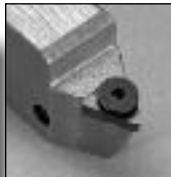

6-Edge Replaceable Type
Lowest-cost choice. Holders take 6-edge, replaceable tips. When one edge wears, turn to new surface. Never need to resharpen – just replace the tip.

The more you buy, the more you save!

Order 10 - 29 Tips, save 10% off jobber
Order 30 or more, save 20% off jobber

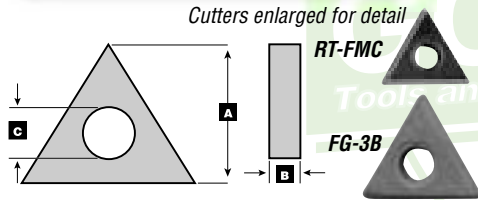

Replacement Tips & Parts

• Fit most boring bar holders

A	B	C	Edges	Jobber	Order No.
Standard Carbide					
.358"	.097"	.108"	3	\$16.99	SEQ-1
.345"	.094"	.140"	6	8.49	RT-6B
.447"	.124"	.149"	3	3.49	RT-FMC
.360"	.094"	.124"	3	9.49	FG-3B
.327"	.094"	.140"	3	10.99	RL-2T
Titanium Coated					
.345"	.094"	.140"	6	\$9.49	RT-6BT
Related Accessories					
Replacement Torx Screw				\$2.29	FG-8103

Van Norman, Peterson or KI OE Catspaw Screws For 777S or PK-447S & 944S

Description	Jobber	Order No.
Catspaw Screws (1 each)		
For #1 Shoe (0.625"L)	\$5.99	800-114
For #2 Shoe (0.740"L)	5.99	800-115
For #3, 4 & 5 Shoe (0.940"L)	5.99	800-116

WINONA VAN NORMAN, VAN NORMAN, PETERSON, KI (PK447S)

1-EDGE CUTTER BIT

Fits Model Numbers	For	Bit Dia.	Jobber	Order No.
777, 900, 905, 944, 965	General	1/4"	\$39.99	VN-1
777S, 777S4, 944S, CB11, BC22XL	General	3/8"	38.99	VGS-1
	Hard Sleeves	3/8"	38.99	VGS-2
	Sleeve Cutter	3/8"	38.99	VGS-3

Original Van Norman

Fits Model Numbers	For	Bit Dia.	Jobber	Order No.
777S, 944S	Hard Sleeves	3/8"	\$36.99	777-179

HOLDERS FOR 6-EDGE TIPS - Use RT-6B and RT-6BT

Fits Model Numbers	Length	Height	Jobber	Order No.
777, 900, 905, 944, 965	1 7/8"	3/4"	\$171.29	VN-135
	2 1/2"	3/4"	149.79	VN-136

777S, 777S4, 944S

Bore Range: 2.65" to 4.50"	Length	Height	Jobber	Order No.
	2"	1 3/16"	159.79	VN-122

Standard Carbide Replacement Cutter Tip	8.49	RT-6B
Titanium Coated Carbide Replacement Tip	9.49	RT-6BT

Fits Model Numbers - Use FG-3B	For	Jobber	Order No.
CB11, CB22XL	3/8" diameter	\$72.79	VN-129
	Standard Carbide Replacement Cutter Tip	9.49	FG-3B

MISCELLANEOUS PARTS

Fits 6-Edge Holders Above	Description	Jobber	Order No.
	Bit Screw	\$3.29	VN-130
	Lock Screw	3.29	VN-132
	Nylon Ball	4.29	VN-133

KWIK-WAY

1-EDGE CUTTER BIT FOR OE HOLDERS

Fits Model Numbers	Type	Bit Dia.	Jobber	Order No.
F, FT, FL, FN, FR, FS,	Rough	5/16"	\$27.29	KWL-R
FW, FWS, FWSII, FX	Finish	5/16"	29.49	KWL-F
Models After 1770	Sleeve Cutter	5/16"	30.49	KWL-C

HOLDER FOR 6-EDGE TIPS - Uses RT-6B or RT-6BT Tips

Fits Model Numbers	Length	Height	Jobber	Order No.
FL, FN, FR, FS, FT, FW	2 9/16"	5/8"	\$141.49	KWL-116
	Standard Carbide Replacement Cutter Tip	8.49	RT-6B	
	Titanium Coated Carbide Replacement Cutter Tip	9.49	RT-6BT	

PETERSON-BERCO

1-EDGE CUTTER BIT FOR OE HOLDERS

Fits Model Numbers	Length	Bit Dia.	Jobber	Order No.
ACP-151-A, ACP-151-BL, SCP-151-P	1 3/4"	10mm	\$32.99	PB-151

ROTTLER

1-EDGE CUTTER BIT FOR OE HOLDERS

Fits Model Numbers	Length	Bit Dia.	Jobber	Order No.
All Bars	1 3/4"	1 1/32"	\$20.99	RL-1
Sleeve Cutter for All Bars	1 3/4"	1 1/32"	31.49	RL-1C

HOLDER WITH 3-EDGE TIP - Includes one RL-2T Tip

Fits Model Numbers	Length	Bit Dia.	Jobber	Order No.
All Bars	1 1/4"	1 1/32"	\$25.99	RL-2H
	Replacement Screw for RL-2H		2.99	RL-2S
	Replacement Cutter Tip		10.99	RL-2T

STORM-VULCAN

1-EDGE CUTTER BIT FOR OE HOLDERS

Fits Model Numbers	Length	Bit Dia.	Jobber	Order No.
NS, BCG, BCT, 220, 260	3/4"	5/16"	\$41.99	S-1



Visit: www.goodson.com/BoringBar for more information and to order

Cylinder Boring & Honing

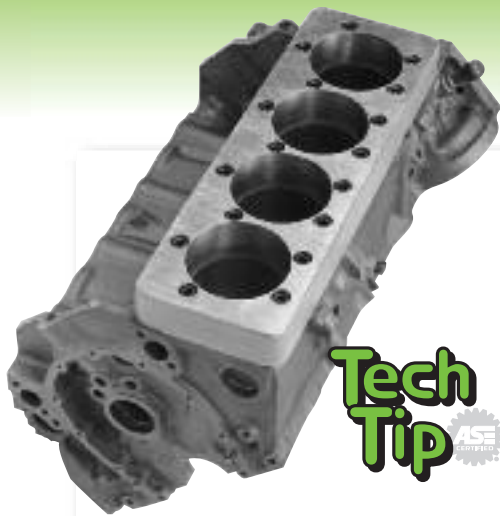

Tech Tip

Head-bolt torque can distort cylinders as much as .004". If you bore and hone a cylinder without using a torque plate, expect up to this much head distortion. Torque plates create head-bolt stress and draw cylinders into their operating shape for boring or honing. Torque plates help you rebuild your block properly with greater precision.

Bore hole size is .080" over standard bore size.



Tensioner Stop Block for Chrysler 2.7 DOHC

- Eliminate broken timing chains, bent valves and chain backlash
- For VIN code R, U & V
- Mechanically supports hydraulic adjusters
- Use with plunger screw or bottom plate tensioners

Application	Jobber	Order No.
For New Chain & Tensioner	\$29.99	DT-27
For Used Chain (modifications may be required)	29.99	DT-27U

Boring Bar O-Ring Cutter Replaceable Tool Bits

- Cut grooves for O-rings to enhance gasket sealing for high-performance engines
- Machines a groove .037" wide • Holders available by special order

Description	Jobber	Order No.
Standard	\$67.99	KWVN-57
Premium	84.99	KWVN-57C6

1 lb. Roll Copper or Stainless Steel O-Ring Wire

- Copper: .0403" dia.
- Stainless: .0410" dia.

Description	Jobber	Order No.
Copper	\$77.49	OWC-0403
Stainless Steel	62.99	OWS-041

Torque Plates for Use with a Portable Bar

- Genuine BHJ Torque Plates modified to GOODSON specifications
- Parallel blanchard ground • Heat-treated • Bolts included (unless noted)
- Bore size is .080" over standard bore size

Fits	Displacement	Material	Bolts	Jobber	Order No.
Chevy – with Cap-Screw Bolts for tight clearances					
V8 Small Block	265-350	Cast Iron	✓	\$349.99	HGM-1
V8 Small Block	400	Cast Iron	.060" over standard bore	349.99	HGM-1A
V8 Big Block	396-454	Cast Iron	✓	399.99	HGM-2
Chevy – use your existing fasteners (washers / spacers provided)					
LS-1	350	Billet Alum.		\$609.99	HGM-LS1
Big Block Bowtie		Cast Iron		509.99	HCH-3-R-S
Chrysler					
V8 Small Block	273-360	Cast Iron	✓	\$349.99	HCR-4
V8 Big Block	361-440	Cast Iron	✓	399.99	HCR-6
Ford					
V8 Small Block	260-302 351-400	Cast Iron	7/16" 1/2"	\$369.99	HFO-7
V8 Big Block	429-460	Cast Iron	✓	399.99	HFO-9A
V8 Small Block	4.6L	T6 Alum.		679.99	HFO-46R
2300	2.3L	Cast Iron	✓	349.99	HFO-23

✓ Replacement Bolts and Washers are available

16" Deck File

- File and handle sold separately

Description	Jobber	Order No.
16" File	\$46.29	FI-16
Handle	5.29	FH-16
File Cleaner	11.99	FC-10

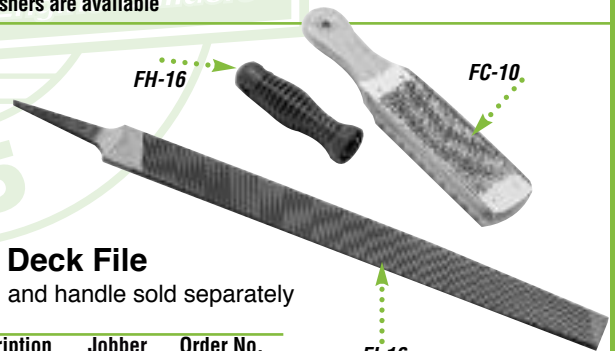

Boring Bar O-Ring Cutter Replaceable Tool Bits

- Cut grooves for O-rings to enhance gasket sealing for high-performance engines
- Machines a groove .037" wide • Holders available by special order

Description	Jobber	Order No.
Standard	\$67.99	KWVN-57
Premium	84.99	KWVN-57C6

1 lb. Roll Copper or Stainless Steel O-Ring Wire

- Copper: .0403" dia.
- Stainless: .0410" dia.

Description	Jobber	Order No.
Copper	\$77.49	OWC-0403
Stainless Steel	62.99	OWS-041

Diamond Laps & Accessories

- A light coat cools and lubricates
- Remove build-up with Lint-Free Cloth and Dressing Stick while lap rotates

Diamond Laps				
Machine	OD	ID	Jobber	Order No.
Kwik-Way	3/4"	1/2"	\$239.99	LP-KW
Rottler	13/4"	1/4"	179.99	LP-RFA
WVN, VN, Peterson, KI 700 series	2 1/2"	15mm	209.99	LP-VNF
Accessories				
Very Fine Lap Oil	1/2 pint		\$10.99	LP-LO
Dressing Stick	1 stick		8.99	LP-DS

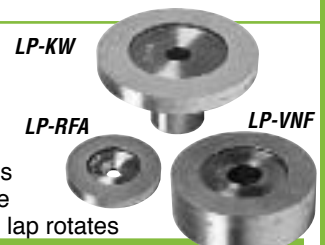

CYLINDER HEAD REBUILDING
CLEANING, ASSEMBLY & SAFETY
SHORT BLOCK REBUILDING
CRANKSHAFT/FLYWHEEL GRINDING
BRAKE & ALIGNMENT TOOLS
MEASURING TOOLS
OFFROAD BIKE, ATV HARD PARTS
V-TWIN HARD PARTS

Full Service ... FAST!



"We offer every customer the opportunity to open a Goodson account for faster, easier ordering and to save you money on C.O.D. shipments. Call today for details!"

- Diane, Goodson Customer File Maintenance - 11 years of service

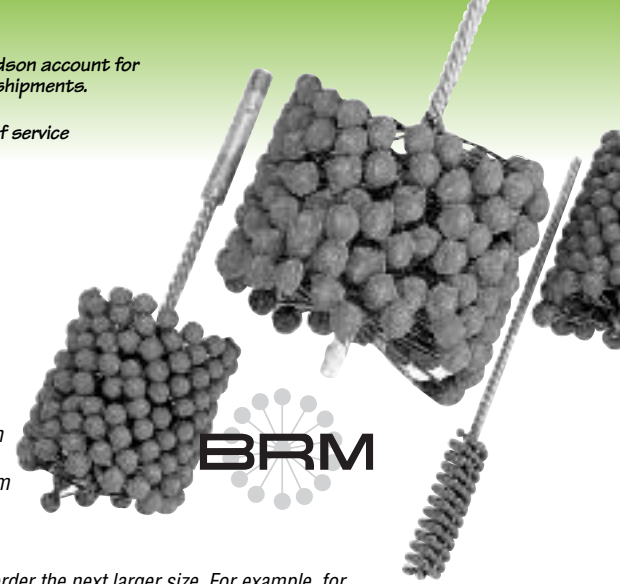

Flex-Hones®

For any type and size of cylinder

- Abrasive globules each have independent suspension • Self-centering
- Self-aligning to the bore • Self-compensating for wear • Applications are interchangeable, select bore size • See page 117 for Brake Rotor Flex-Hones®
- Plateau Soft Hones on page 79

Silicon-Carbide Flex-Hones®
Ideal for all materials including cast iron, bronze, phosphor bronze and aluminum.

Aluminum-Oxide Flex-Hones®
Ideal for hard surfaces such as Nicasil and hardened steel

Diamond Flex-Hones®
Ideal for heat treated steel, high nickel stainless steel, chromes or plated bores, MMX aluminum alloys, ceramics and carbide

Ordering the right size Flex-Hone®

Order by actual cylinder ID. All Flex-Hones® are produced oversize. If your cylinder ID is non-standard, order the next larger size. For example, for a cylinder that has been machined to 3/8" diameter, order a 3/8" cylinder hone. The "flex" that's built into the Flex-Hone® will adjust to the size difference.
NOTE: If purchasing the 120 Grit Heavy Duty Flex-Hones®, order on cylinder size.

		Silicon-Carbide Flex-Hones®														
		120 Grit Standard			120 Grit Heavy-Duty			180 Grit Standard			180 Grit - Long			320 Grit Standard		
Size	mm	OAL	Jobber	Order No.	OAL	Jobber	Order No.	OAL	Jobber	Order No.	OAL	Jobber	Order No.	OAL	Jobber	Order No.
5/8"	15.9							8"	\$20.79	BH-625						
3/4"	19.1							8"	21.79	BH-750						
13/16"	20.6							8"	22.79	BH-820						
7/8"	22.2							8"	22.79	BH-875						
1"	25.4							8"	23.79	BH-1000						
1 1/8"	28.6							8"	24.79	BH-1125						
1 1/4"	31.8							8"	25.79	BH-1250				8"	\$28.99	BG-125320
1 3/8"	34.9							8"	25.79	BH-1375						
1 1/2"	38.1							8"	25.79	BH-1500				8"	31.99	BG-150320
1 5/8"	41.3							8"	25.79	BH-1625				8"	32.99	BG-162320
1 3/4"	44.5							8"	27.99	BH-1750				8"	33.99	BG-175320
2"	50.8	8"	\$29.99	BG-210				8"	27.99	BH-2000	18"	\$42.29	CBF-175	8"	35.29	BG-200320
2 1/4"	57.2	8"	30.99	BG-225				8"	30.99	BH-2250	18"	43.29	CBF-200	8"	40.29	BG-225320
2 1/2"	63.5	8"	32.99	BG-250				8"	31.99	BH-2500	18"	43.29	CBF-225			
2 3/4"	69.8	8"	35.29	BG-275				8"	35.29	BH-2750	18"	43.29	CBF-250			
3"	76.2	8"	40.29	BG-300	14"	\$66.99	BGD-300							8"	59.79	BG-300320
3 1/4"	82.6	14"	43.29	BG-325	14"	66.99	BGD-325							14"	59.79	BG-325320
3 1/2"	88.9	14"	47.49	BG-350	14"	62.99	BGD-350							14"	67.99	BG-350320
3 3/4"	95.3	14"	50.49	BG-375	14"	62.99	BGD-375							14"	73.29	BG-375320
4"	101.6				14"	77.29	BGD-400									
4 1/8"	104.8	14"	52.79	BG-425										14"	77.29	BG-425320
4 1/4"	107.9				14"	82.49	BGD-425									
4 1/2"	114.3				14"	87.79	BGD-450									
4 5/8"	117.5	14"	59.79	BG-462										14"	85.49	BG-462320
5"	127.0				18"	92.79	BGD-500									
5 1/2"	139.7				18"	97.79	BGD-550									
6"	152.4				18"	108.29	BGD-600									
6 1/2"	165.1				18"	113.29	BGD-650									
7"	177.8				18"	128.79	BGD-700									
7 1/2"	190.5				18"	144.29	BGD-750									
8"	203.2				18"	154.99	BGD-800									

Aluminum Oxide Flex-Hones® For Nicasil

240 Grit Standard			
Size	mm	OAL	Jobber Order No.
2 1/4"	57.2	8"	\$39.29 BA-225240
2 3/8"	60.2	8"	40.29 BA-237240
2 1/2"	63.5	8"	41.29 BA-250240
2 5/8"	66.5	8"	42.29 BA-262240
2 3/4"	69.8	8"	43.29 BA-275240
3"	76.2	8"	50.49 BA-300240
3 1/4"	82.6	13"	58.79 BA-325240
3 1/2"	88.9	13"	60.79 BA-350240
3 3/4"	95.3	13"	65.99 BA-375240
4 1/4"	107.9	13"	73.29 BA-425240
4 5/8"	117.5	13"	78.29 BA-462240

Valve Guide Flex-Hone Kit

Order No. **VG-F-KIT** Flex-Hones® shaded in green are included. Jobber \$82.99

		240 Grit Silicon-Carbide		400 Grit Diamond				240 Grit Silicon-Carbide		400 Grit Diamond	
Size	mm	OAL	Order No.	Order No.		Size	mm	OAL	Order No.	Order No.	
5/32"	4.0	6"	VG-F-4MM	VGFD-4MM		1 1/32"	9.0	8"	VG-F-9MM	VGFD-9MM	
1 1/64"	4.5	6"	VG-F-4.5MM	VGFD-4.5MM		3/8"	10.0	8"	VG-F-10MM	VGFD-10MM	
1 3/64"	5.0	8"	VG-F-5MM	VGFD-5MM		7/16"	11.0	8"	VG-F-11MM	VGFD-11MM	
7/32"	5.5	8"	VG-F-5.5MM	VGFD-5.5MM		1 5/32"	12.0	8"	VG-F-12MM	VGFD-12MM	
1/4"	6.4	8"	VG-F-6.4MM	VGFD-6.4MM		3 3/64"	13.0	8"	VG-F-13MM	VGFD-13MM	
9/32"	7.0	8"	VG-F-7MM	VGFD-7MM		9/16"	14.0	8"	VG-F-14MM	VGFD-14MM	
5/16"	8.0	8"	VG-F-8MM	VGFD-8MM		1 9/32"	15.0	8"	VG-F-15MM	VGFD-15MM	
Jobber		\$22.99	\$34.99			Jobber		\$22.99	\$34.99		

order at 1-800-533-8010 (outside the US & Canada, 1-507-452-1830) or online at www.goodson.com

Coolants and Lubricants

We don't stock one type of coolant and claim that it suits all types of grinding, nor do we carry one type of oil and try to sell it for every application. Each of our many types of coolants, lubricants and oils is formulated to deliver better results and longevity in its specific use. All of our coolants prolong the life of grinding wheels, retard corrosion and rancidity. Colors may vary.



All-Purpose Grinding Coolant (Green)

A synthetic water soluble coolant that "Licks Rust". Dilute 30:1

Size	Yield	Jobber	Order No.
1 gallon	30 gallons	\$ 29.99	CGC-1288
5 gallons	150 gallons	134.99	CGC-5288

Crank & Cam Grinding Coolant (Amber)

Synthetic, non-nitrate, high lubricity coolant. Dilute 20:1

Size	Yield	Jobber	Order No.
1 gallon	20 gallons	\$ 33.99	CGC-10
5 gallons	100 gallons	149.99	CGC-50

Multi-Duty Grinding Coolant (Pink)

Medium-duty, low foaming, synthetic coolant with rust inhibitors. Safe for ferrous and non-ferrous metals. No nitrates, phenols, chlorine, sulfur. Dilute 30:1

Size	Yield	Jobber	Order No.
1 gallon	30 gallons	\$ 34.99	GPC-10
5 gallons	150 gallons	169.99	GPC-50

Resurfacing Coolant (Amber)

Non-foaming, non-nitrate coolant for single-piece or segmented wheels. Dilute 20:1

Size	Yield	Jobber	Order No.
1 gallon	20 gallons	\$ 29.99	SGC-10
5 gallons	100 gallons	124.99	SGC-50

Belt-Resurfacing Coolant (Pink)

For all belt-type resurfacers with or without down-pressure. Dilute 30:1

Size	Yield	Jobber	Order No.
1 gallon	30 gallons	\$ 26.99	SGB-10
5 gallons	150 gallons	129.99	SGB-50

Flywheel Grinding Coolant (Blue)

A synthetic rust inhibitor that prevents rancidity. For all grinders. Dilute 30:1

Size	Yield	Jobber	Order No.
1 gallon	30 gallons	\$ 41.99	FG-1101-G
5 gallons	150 gallons	149.99	FG-1102-G

Cutting Oils

Knurlube

Lubricate while knurling.

Size	Jobber	Order No.
½ pint	\$ 8.99	WLB-46-G
1 quart	13.99	WLB-47-G



Valve Seat Cutting Fluid

High-silicone lube cuts drag on cutters for a better finish, longer tool life. Dilute 9:1

Size	Jobber	Order No.
1 pint spray	\$13.79	SCF-2
1 gallon	26.99	SCF-10



Lap Oil

This very fine oil prolongs the life of diamond laps. A light coat coats, lubricates and prevents wear.

Size	Jobber	Order No.
½ pint	\$10.99	LP-LO



Cutting Aids (Aerosol)

Helps tools cut through the hardest of metals. Clings to the surface of the tool, keeping it cool while prolonging its life.

Size	Jobber	Order No.
Cutting & Tapping Fluid	\$ 9.99	CTF-14
Resurfacing Spray	11.99	HPS-16



Bronze Reaming Oil

Cuts bronze build-up while reaming. Longer tool life. Better valve guide finish.

Size	Jobber	Order No.
1 pint	\$ 9.99	BW-303-G
1 quart	15.99	BW-303A-G
1 gallon	35.99	BW-305-G



Tap Oil

Makes tapping easier & faster. Breaks down surface tension. Eliminates scuff marks & gouging. Reduces tap breakage & improves thread quality.

Size	Jobber	Order No.
7.5 ounces	\$15.79	TAP-O



Grinding & Honing Oils

Cylinder Honing Oil (Clear)

Ideal for portable hones and all makes of automotive honing machines. Readily mixes with other brands (including Sunnen). **Not** water soluble.

Size	Jobber	Order No.
1 gallon	\$21.99	HO-10
5 gallons	97.99	HO-50



Diamond Honing Oil (Brown)

Specially formulated to withstand the cutting pressures created when using our Diamond Valve Guide Honing System.

Size	Jobber	Order No.
8 fl. oz.	\$ 4.99	DHO-8
1 gallon	28.99	DHO-10
5 gallons	124.99	DHO-50



Rod Honing Oil (Dark Brown)

Keeps stones clean and free-cutting during rod reconditioning, pin fitting and other honing applications. Will mix with other brands, including Sunnen.

Size	Jobber	Order No.
1 gallon	\$ 29.99	RHO-10
5 gallons	134.99	RHO-50



Valve Grinding Oil (Light Yellow)

Universal valve grinding oil extends wheel life.

Size	Jobber	Order No.
1 gallon	\$ 29.99	VGO-10
5 gallons	119.99	VGO-50



Titanium Valve Grinding Aid

32 oz. \$41.99 **VGA-T32**



Machine Lubricants

Flywheel Grinder Table Lubricant

Helps extend flywheel grinder life. This high-pressure oil is designed to lubricate table bearings and ways. For all makes of flywheel grinders.

Size	Jobber	Order No.
1 gallon	\$36.99	FG-1131-G



Way Oil

Adhesive oil formulated to provide extended lubrication and rust protection for machine-tool ways.

Size	Jobber	Order No.
1 gallon	\$21.99	WO-50



Rust Shield for Shop Equipment

Prevents rust, but won't cause rancidity. Protective film mixes with coolant so you don't have to clean it off before using the machine.

Size	Jobber	Order No.
1 gallon	\$25.99	RS-128



Need a larger quantity?

Ask us about getting coolants and lubricants in bulk.



Junior Midget Portable Cylinder Hone

- Range: 1¼"-1¾" • 2" drive shank and 12" extension
- Stones sold separately
- 7/16"-14 thread
- Order No. **SNJ-10** Jobber \$489.99

Midget Portable Cylinder Hone

- Range: 1¾"-2" • 2" drive shank and 12" extension • Stones sold separately
- 7/16"-14 thread
- Order No. **SN-75** Jobber \$396.49

Junior Portable Cylinder Hone

- Range: 2"-2.6" • 2" drive shank and 12" extension • Stones sold separately
- 7/16"-14 thread
- Order No. **JN-95** Jobber \$406.99

Standard Portable Cylinder Hone

- Range: 2½"-5½" • 2" drive shank and 12" extension
- Stones sold separately
- 7/16"-14 thread
- Order No. **AN-112** Jobber \$424.29

Heavy-Duty Portable Cylinder Hone

- Range: 2½"-5½" • 2" drive shank and 12" extension
- Stones sold separately
- 5/8"-11 thread
- Heavy-duty universal joint
- Order No. **AN-815** Jobber \$599.99

Goodson Standard Portable Cylinder Hone

- Range: 2½"-5½" • 12" drive shank
- 220 Grit (HN-301S) stones included
- 7/16"-14 thread
- Order No. **HN-218** Jobber \$369.99

Goodson Heavy-Duty Portable Cylinder Hone

- Range: 2½"-5½" • 12" drive shank
- 220 Grit (HN-301S) stones included
- 5/8"-11 thread
- Order No. **HN-218HD** Jobber \$499.99



Commonly used with ½" non-pistol grip drill. Heavy Duty can also be used in manual hone cabinet.



Lisle® Small Diameter Portable Honing Set

- Precision built specifically for small cylinders
- Stones measure 3½"/88.9mm long • 4 grits

Small Cylinder Hone Starter Set

- Includes hone plus 3 sets of 180 grit stones to fit full range, Allen wrench and storage case
- Order No. **HL-1600** Jobber \$219.99

Replacement Stone & Wiper Set

- Includes 2 stones & felt wipers • Choose from grits below

80 Grit

Range in/mm	Order No.
1.75"-2.20"/44.5-55.8	HL-1644
2.05"-2.50"/51.4-63.5	HL-1645
2.35"-2.75"/59.7-69.8	HL-1646

180 Grit

Range in/mm	Order No.
1.75"-2.20"/44.5-55.8	HL-1641
2.05"-2.50"/51.4-63.5	HL-1642
2.35"-2.75"/59.7-69.8	HL-1643

Jobber \$19.99

280 Grit

Range in/mm	Order No.
1.75"-2.20"/44.5-55.8	HL-1638
2.05"-2.50"/51.4-63.5	HL-1639
2.35"-2.75"/59.7-69.8	HL-1640

Nicasil

Range in/mm	Order No.
1.75"-2.20"/44.5-55.8	HL-1657
2.05"-2.50"/51.4-63.5	HL-1658
2.35"-2.75"/59.7-69.8	HL-1659

Jobber \$19.99

Honing Stones For Midget & Junior Hones



- Sets have 2 holders with 4" integral stones and 2 holders with integral aluminum wipers • Ideal for Cast Iron

Grit	Range	mm	Finish	Order No.
70 Grit Roughing	1.75" - 2.00"	44.5-50.8	120 Ra	SN-100
	2.00" - 2.20"	50.8-55.9	120 Ra	JN-100
	2.20" - 2.40"	55.9-60.9	120 Ra	JN-101
	2.40" - 2.60"	60.9-66.0	120 Ra	JN-102
150 Grit Medium	1.25" - 1.44"	31.8-36.6	45 Ra	SNJ1-J45
	1.42" - 1.60"	36.1-40.6	45 Ra	SNJ2-J45
	1.58" - 1.77"	40.1-44.9	45 Ra	SNJ3-J45
	1.75" - 2.00"	44.5-50.8	45 Ra	SN-200
	2.00" - 2.20"	50.8-55.9	45 Ra	JN-200
	2.20" - 2.40"	55.9-60.9	45 Ra	JN-201
220 Grit Finishing	2.40" - 2.60"	60.9-66.0	45 Ra	JN-202
	1.75" - 2.00"	44.5-50.8	32 Ra	SN-300
	2.00" - 2.20"	50.8-55.9	32 Ra	JN-300
280 Grit Fine Finishing	2.20" - 2.40"	55.9-60.9	32 Ra	JN-301
	1.75" - 2.00"	44.5-50.8	20 Ra	SN-500
	2.00" - 2.20"	50.8-55.9	20 Ra	JN-500
400 Grit Xtra-fine Finish	2.20" - 2.40"	55.9-60.9	20 Ra	JN-501
	2.40" - 2.60"	60.9-66.0	20 Ra	JN-502
	1.25" - 1.44"	31.8-36.6	8 Ra	SNJ1-J87
	1.42" - 1.60"	36.1-40.6	8 Ra	SNJ2-J87
	1.58" - 1.77"	40.1-44.9	8 Ra	SNJ3-J87
	1.75" - 2.00"	44.5-50.8	8 Ra	S18-J87
	2.00" - 2.20"	50.8-55.9	8 Ra	T20-J87
	2.20" - 2.40"	55.9-60.9	8 Ra	U22-J87
	2.40" - 2.60"	60.9-66.0	8 Ra	V24-J87

Jobber \$26.79 each

CYLINDER HEAD REBUILDING
CLEANING, ASSEMBLY & SAFETY
SHORT BLOCK REBUILDING
CRANKSHAFT/ FLYWHEEL GRINDING
BRAKE & ALIGNMENT TOOLS
MEASURING TOOLS
OFFROAD BIKE, ATV HARD PARTS
V-TWIN HARD PARTS



The more you buy, the more you save!
 Order 5 or more GOODSON HN Stones, save 10% off jobber

Goodson or Sunnen® Cylinder Honing Stones
For all popular AN-style Honers and Hone Bodies

- Integral holder type sets have 4 pieces: 2 holders with stones and 2 holders with aluminum wipers
- Fit Sunnen® AN Standard, AN Heavy-Duty and Goodson **HN-218** and **HN-218HD** hones
- Use with honing oil
- Stones for Short or Blind Holes are 2 1/16" long; All other stones are 4" long

Bore Range					SUNNEN® For power hones or portable hones			GOODSON For power hones or portable hones For power hones only			
Grit	in	mm	Usage	Finish	Jobber	Order No.	Sunnen No.	Jobber	Order No.	Jobber	Order No.
70 Grit Roughing	2.5"-2.7"	63.5-68.6	Cast Iron	120 Ra	\$24.79	AN-115	G25-J17	_____	_____	_____	_____
	2.7"-4.1"	68.6-104.1	Cast Iron	120 Ra	24.79	AN-100	M27-J17	\$21.99	HN-100	\$21.99	HN-100
			Cast Iron	120 Ra	_____	_____	_____	21.99	HN-100R¹	21.99	HN-100R¹
			Short/Blind	120 Ra	24.79	AN-100-71	M27-J17-71	21.99	HN-102	21.99	HN-102
	3.5"-5.5"	88.9-139.7	Harley / VW	120 Ra	24.79	AN-100F	AN-100F	_____	_____	_____	_____
			Cast Iron	120 Ra	24.79	AN-101	N37-J17	21.99	HN-101	21.99	HN-101
			Cast Iron	120 Ra	_____	_____	_____	_____	21.99	HN-101R¹	21.99
	4.7"-15.0"	119.4-381	Short/Blind	120 Ra	24.79	AN-101-71	N37-J17-71	21.99	HN-104	21.99	HN-104
			Hard Sleeves	55 Ra	24.79	AN-131	N37-J11	_____	_____	_____	_____
			Cast Iron	120 Ra	24.79	AN-106²	W47-J17	_____	_____	_____	_____
150 Grit Medium	2.5"-2.7"	63.5-68.6	Hard Sleeves	55 Ra	24.79	AN-136²	W47-J11	_____	_____	_____	_____
			Cast Iron	45 Ra	24.79	AN-215	G25-J45	21.99	HN-215S	_____	_____
	2.7"-4.1"	68.6-104.1	Cast Iron	45 Ra	24.79	AN-200	M27-J45	21.99	HN-200S	21.99	HN-200
			Short/Blind	45 Ra	24.79	AN-200-71	M27-J45-71	21.99	HN-202S	21.99	HN-202
			Hard Sleeves	30 Ra	_____	_____	_____	21.99	HN-230S	_____	_____
	3.5"-5.5"	88.9-139.7	Cast Iron	45 Ra	24.79	AN-201	N37-J45	21.99	HN-201S	21.99	HN-201
			Short/Blind	45 Ra	24.79	AN-201-71	N37-J45-71	21.99	HN-204S	21.99	HN-204
			Hard Sleeves	30 Ra	24.79	AN-231	N37-J43	21.99	HN-231S	_____	_____
	4.7"-15.0"	119.4-381.0	Cast Iron	45 Ra	24.79	AN-206²	W47-J45	21.99	HN-206S²	_____	_____
			Hard Sleeves	30 Ra	24.79	AN-236²	W47-J43	21.99	HN-236S²	_____	_____
220 Grit Finishing	2.7"-4.1"	68.6-104.1	Cast Iron	32 Ra	24.79	AN-300	M27-J55	21.99	HN-300S	21.99	HN-300
			Short/Blind	32 Ra	24.79	AN-300-71	M27-J55-71	21.99	HN-302S	21.99	HN-302
	3.5"-5.5"	88.9-139.7	Cast Iron	32 Ra	24.79	AN-301	N37-J55	21.99	HN-301S	21.99	HN-301
			Short/Blind	32 Ra	24.79	AN-301-71	N37-J55-71	21.99	HN-304S	21.99	HN-304
4.7"-15.0"	119.4-381	Cast Iron	32 Ra	24.79	AN-306²	W47-J55	21.99	HN-306S²	_____	_____	
		Hard Sleeves	30 Ra	24.79	AN-306²	W47-J43	21.99	HN-306S²	_____	_____	
280 Grit Fine Finish	2.5"-2.7"	63.5-68.6	Cast Iron	20 Ra	24.79	AN-515	G25-J65	21.99	HN-515S	_____	_____
			Cast Iron	20 Ra	24.79	AN-500	M27-J65	21.99	HN-500S	21.99	HN-500
	2.7"-4.1"	68.6-104.1	Short/Blind	20 Ra	23.79	AN-500-71	M27-J65-71	21.99	HN-502S	21.99	HN-502
			Hard Sleeves	12 Ra	24.79	AN-530	M27-J63	_____	_____	_____	_____
			Cast Iron	20 Ra	24.79	AN-501	N37-J65	21.99	HN-501S	21.99	HN-501
	3.5"-5.5"	88.9-139.7	Short/Blind	20 Ra	24.79	AN-501-71	N37-J65-71	21.99	HN-504S	21.99	HN-504
			Hard Sleeves	12 Ra	_____	_____	_____	21.99	HN-531S	_____	_____
			Hard Sleeves	12 Ra	24.79	AN-536²	W47-J63	_____	_____	_____	_____
	4.7"-15.0"	119.4-381.0	Cast Iron	20 Ra	24.79	AN-506²	W47-J65	_____	_____	_____	_____
			_____	_____	_____	_____	_____	_____	_____	_____	
400 Grit Extra Fine Finish	2.5"-2.7"	63.5-68.6	Cast Iron	8 Ra	24.79	G25-J87	G25-J87	_____	_____	_____	_____
			Cast Iron	8 Ra	24.79	M27-J87	M27-J87	21.99	HN-600	21.99	HN-600
	2.7"-4.1"	68.6-104.1	Hard Sleeves	5 Ra	24.79	M27-J85	M27-J85	_____	_____	_____	_____
			Cast Iron	8 Ra	25.79	N37-J87	N37-J87	21.99	HN-601	21.99	HN-601
600 Grit Polishing	2.5"-3.3"	63.5-83.8	Hard Sleeves	5 Ra	25.79	N37-J85	N37-J85	_____	_____	_____	_____
			Cast Iron*	2-3 Ra	29.99	G25-C05	G25-C05	_____	_____	_____	_____
			Cast Iron*	2-3 Ra	47.49	MM33-C05	MM33-C05	_____	_____	_____	_____
3.3"-4.2"	83.8-106.7	Cast Iron*	2-3 Ra	41.49	NN40-C05	NN40-C05	_____	_____	_____	_____	
		Cast Iron*	2-3 Ra	41.49	NN40-C05	NN40-C05	_____	_____	_____	_____	

(*Cast Iron – 3 Ra., Hard Sleeves – 2 Ra., Steel – 3 Ra.)

¹Aluminum oxide abrasive for longer life in rough cutting use ²Use with Master Holder Sets and Stone Supports
Sunnen has changed their part numbers. We have listed the Sunnen industrial numbers to the right of our order number for your convenience.

Master Holder & Stone Supports

- Holds one 4" stone set
- Stones sold separately
- AN-365 requires use of AN-260



Master Holder			
Dia. Range	Jobber	Order No.	
4.7"-7.0"	\$111.99	AN-355	
6.0"-9.0"	113.99	AN-365	
Stone Supports for AN-365			
6.0"-9.0"	\$66.99	AN-260	

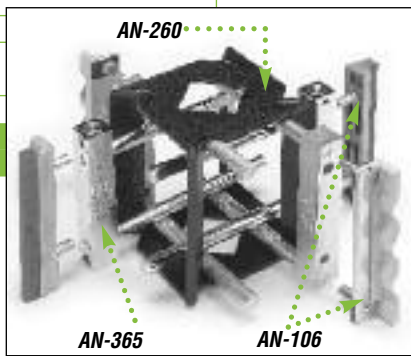

from one to one thousand, no minimum orders required

CYLINDER HEAD REBUILDING
 CLEANING, ASSEMBLY & SAFETY
 SHORT BLOCK REBUILDING
 CRANKSHAFT/ FLYWHEEL GRINDING
 BRAKE & ALIGNMENT TOOLS
 MEASURING TOOLS
 OFFROAD BIKE, ATV HARD PARTS
 V-TWIN HARD PARTS

Full Service ... FAST!



"At Goodson, we believe that customers are our friends who deserve dedication. Everything we do is driven by that idea. You can count on us to be your most reliable source for shop supplies."
- Corinne, Goodson Sales Associate, 8 years of service

Keyway Honing Stone Sets



- Two-stroke engines have intake and exhaust ports that interrupt the operation of your honing stone • These stones allow the hone to pass the intake and exhaust ports while maintaining consistent pressure to remove material accurately and easily • Use with any AN-series or HN-series hone
- For Cast Iron



Grit	Range	mm	Finish	Jobber	Order No.
150 Grit	2.5" - 3.3"	63.5-83.8	45 Ra	\$50.49	GY25-J45
	3.3" - 4.2"	83.8-106.7	45 Ra	45.49	MY33-J45
280 Grit	2.5" - 3.3"	63.5-83.8	20 Ra	50.49	GY25-J65
	3.3" - 4.2"	83.8-106.7	20 Ra	45.49	MY33-J65
400 Grit	2.5" - 3.3"	63.5-83.8	8 Ra	50.49	GY25-J85
Extra Fine	3.3" - 4.2"	83.8-106.7	8 Ra	45.49	MY33-J85



C30-PHT-731

Ultra-Finish Plateau Finishing Tools

- For Portable Hones, Hone Cabinets and CV/CK Tooling
- Abrasive impregnated nylon bristles
- Ideal for high-performance rebuilding and rebuilding newer style engines that use low-tension rings
- Superior plateau finish so rings will seal immediately
- Reduces break-in time
- Allows closer tolerances for improved compression, better oil control, lower emissions • Fits AN- or HN-series hones

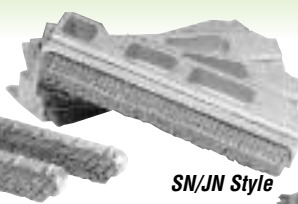

SN/JN Style

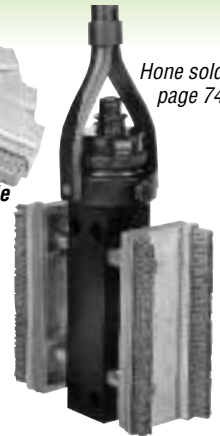

Hone sold page 74

AN Style

For Portable Hones and Hone Cabinets – Includes 1 pair

Hone Body	Dia. Range	mm	Jobber	Order No.
Sunnen SN	2.15" - 2.40"	54.6-60.9	\$299.99	SN-PHT-732
Sunnen JN	2.40" - 2.60"	60.9-66.0	429.99	JNO-PHT-732
AN Style	2.98" - 3.78"	75.7-96.0	269.99	GG-PHT-732
	3.78" - 4.68"	96.0-118.9	269.99	MM-PHT-731
	4.48" - 6.08"	113.8-154.4	391.49	NN-PHT-731

For Sunnen CV / CK Hone Heads – Includes 1 pair

Head	Dia. Range	mm	Jobber	Order No.
Standard	3.10" - 5.00"	78.7-127.0	\$149.49	C30-PHT-731

For the best possible finish, use a Hone Stop (page 74)



C-3070K

C-3120K

Stones & Shoes for Sunnen Hone Machines

- Premium-quality replacements for all CV-616, and CK-10 hones equipped with Sunnen Master Holder Sets
- Diameter Range: 4.125" - 5.000"/ 104.8 - 127.0mm
- Use with Master Holder Set CK-3045A (sold separately)
- 2 stones per set

Stones	Goodson - 1 stone set		Sunnen - 6 stone sets	
	Use	Grit RMS	Jobber	Order No.
Hard Blocks	70	60		\$80.49 EHN-116
Air Cooled Cyl.	70	60		80.49 EHN-123
Hard Blocks	220	22-32		80.49 EHN-512
Air Cooled Cyl.	220	22-32		80.49 EHN-518
Hard Blocks	70	60	\$13.79 HE-123	66.99 EHU-123
Roughing	70	60	13.79 HE-133	66.99 EHU-133
Hard Blocks	220	22-32	13.79 HE-518	66.99 EHU-518
Gen. Purp.	220	22-32	13.79 HE-525	66.99 EHU-525
Aluminum	220	30-36		66.99 JHU-525
High Nickel	280	20-25		66.99 JHU-623
Finishing	280	16-23	13.79 HE-625	66.99 JHU-625
High Nickel	400	7-14		66.99 JHU-818
Aluminum	400	7-14		66.99 JHU-820
Accessories			Qty.	Jobber Order No.
Sunnen® Master Holder Set			1	\$239.79 CK-3045A
Sunnen® Centering Guide (includes CK-3070)			1	112.29 CK-3090A
Sunnen® Guide Shoe & Screw Set			1	18.79 CK-3070
Wear Shoe			2	26.29 C-3070K
Stabilizing Shoe			2	27.29 C-3120K

For Rod Honing Stones and Shoes see page 81



Sunnen® Tooling for Honing Dart Blocks & Ductile Sleeves

- Recommended for Dart™ Machinery
- Use with Sulfurated Rod Honing Oil (RHO-10 or RHO-50) for all stone applications below



C30-A55

CK-3570

Description	Jobber	Order No.
Honing Stone Sets For Portable Tooling		
80 Grit	\$25.79	N37-A25
220 Grit	25.79	N37-A55
280 Grit	24.79	AN-501
400 Grit	37.29	MM33-J85
For CK/CV Type Machines		
80 Grit Stone Set (6)	\$79.79	C30-A25
220 Grit Stone Set (6)	79.99	C30-A55
280 Grit Stone Set (6)	79.99	C30-J65
400 Grit Stone Set (6)	79.99	C30-J85
Titanium Guide Shoe (1)	164.79	CK-3570
Delron Guide Shoe (1)	128.79	CK-3070NY3X



For CK & CV Machines, **DO NOT** use Bronze Guide Shoes, use Titanium and Delron shoes above (1 of each)

CYLINDER HEAD REBUILDING
CLEANING, ASSEMBLY & SAFETY
SHORT BLOCK REBUILDING
CRANKSHAFT/ FLYWHEEL GRINDING
BRAKE & ALIGNMENT TOOLS
MEASURING TOOLS
OFFROAD BIKE, ATV HARD PARTS
V-TWIN HARD PARTS

Cylinder Boring & Honing

Original Ammco Honing Stone Sets

For Ammco 500 Hones

Includes 2 stones and 2 felt wipers • Use dry for best performance

Grit	Qty	OE #	Order No.
60	4	#619	AHS-70
220	4	#620	AHS-220
320	4	#3933	AHS-280
400	4	#621	AHS-400

Jobber \$68.49

For Ammco 3800 Hones

Includes 3 stones • Use liberal amounts of honing oil

Grit	Qty	OE #	Order No.
100	3	#4040	AHS-110
180	3	#3840	AHS-111
280	3	#3810	AHS-112
400	3	#3833	AHS-113

Jobber \$47.99

Lisle® Honing Stone Sets

- Clip-on style mounts in seconds
- 5"/127mm long stones and wipers • Each set contains two stones and two felt wipers
- Use dry

Replaces Lisle® No.	Grit	Order No.
15500	80	HL-80
15510	180	HL-180
15520	280	HL-280
15590	500	HL-500

Jobber \$15.99 per set



"Quick Couplers" Make Honing Easier

- Keeps both hands free for removing hone from cylinder or for stone changing operations

Application	Jobber	Order No.
SN, JN, AN & HN-218 hones, etc. with 7/16"x14 Thread	\$257.99	AN-80
AN-815 Heavy Duty & HN-218HD Hone and others with 5/8" x 11 Thread	\$209.99	AN-85



One-Set Hone Stop Assembly

- Stop-collar meets the deck, preventing the hone from hitting webs and damaging stones or block
- Use full, even strokes to avoid cylinder taper
- Hardened brass thrust bushing
- Includes nylon stop collar
- Set the depth once for faster manual honing



Bushing ID	Jobber	Order No.
1/2" (12.7mm)	\$129.99	HS-150-1/2
5/8" (15.9mm)	129.99	HS-150-5/8
3/4" (19.1mm)	129.99	HS-150-3/4
Replacement 5" diameter Nylon Stop Collar	42.79	HS-RING

82°, 3" Dia. Chamfering Cones & Mandrel



- Chamfer sharp edges for safe piston and ring installation • Handles all diameter cylinders or sleeves
- 82° abrasive cones measure 3 1/2"/88.9mm high with 2"/50.8mm base and 3"/76.2mm top diameter
- Fits 3/8"/9.53mm or larger drill • Kit (**CC-100**) includes mandrel and three 50 Grit Aluminum Oxide cones (**CC-15**)

Description	Jobber	Order No.
3" Top Dia. Chamfering Cone Kit	\$52.99	CC-100
Replacement 3/8" Drill Adaptor	12.99	CC-100-1
Aluminum Oxide Chamfering Cones (red)		
40 Grit	\$7.29	CC-14
50 Grit	7.29	CC-15
80 Grit	7.29	CC-20
Zirconia Chamfering Cones (blue)		
50 Grit	\$7.99	CCZ-15
80 Grit	7.99	CCZ-20

Order 5 or more cones, save 10% off jobber



5"/127mm dia. Chamfering Cones & Mandrel

- Large diameter cones chamfer the top of the cylinder to an exact 45° angle in one pass • 1/2"/12.7mm steel shank permanently embedded in the base • Cone height: 3 1/2"/88.9mm
- Kit includes mandrel & one 36-grit cone



Description	Jobber	Order No.	Incl.
5" Chamfering Cone Kit	\$89.99	CC-130	▼
Chamfering Cones			
Abrasive	Grit		
Aluminum Oxide (red)	36	\$7.99	CC-30 x
	50	7.99	CC-50
	80	7.99	CC-80
Zirconia (blue)	36	8.99	CCZ-36
	50	8.99	CCZ-50
	80	8.99	CCZ-80

Clear Honing Oil

- Helps keep stones clean and free-cutting
- Ideal for portable hones and all makes of automotive honing machines
- Mixes easily with other brands (including Sunnen®)
- Not water soluble



Size	Jobber	Order No.
1 gal./3.78L	\$21.99	HO-10
5 gal./18.9L	97.99	HO-50

CYLINDER HEAD REBUILDING

CLEANING, ASSEMBLY & SAFETY

SHORT BLOCK REBUILDING

FLYWHEEL CRANK

VALVE & ALIGNMENT TOOLS

MEASURING TOOLS

OFFROAD BIKE, ATV HARD PARTS

V-TWIN HARD PARTS

From our customers:

"Your company should hold a seminar on how to run a company. I received your products the day following my order. When ordering from other companies they tell me it'll be 2-4 weeks because they are busy. It's nice to have great service these days. Thank you and keep up the great work!"

- Ray Temple, Waupaca, Wisconsin, Goodson customer since 2009

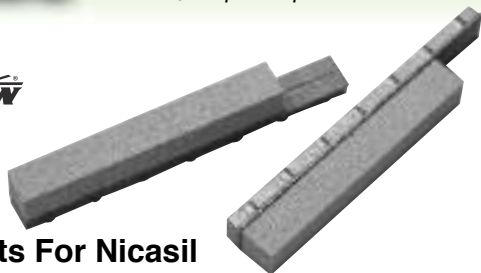

Honing Stone Sets For Nicasil

- For deglazing Nicasil with A CV/CK Honing Machine
- Diameter Range:
 - 3.0" - 5.0" / 76.2-127.0mm in standard automotive head
 - 2.6" - 3.5" / 66.0-88.9mm in junior head
- 150 grit aluminum oxide abrasive
- 6 per set • Order No. **EHU-412** Jobber \$66.99



Tips for Honing Nicasil

Nicasil is an electro-deposited (electroplated) composite of nickel and silicon carbide. Components are uniformly dispersed throughout the resulting material. Care must be used when honing this material as the plating is normally applied in thicknesses no greater than .003". If you remove too much of the Nicasil, you will need to have the cylinder bores replated. The wear ratio on Nicasil is 10:1 so .010" wear in a normal cylinder would be only .001" on Nicasil.

An aluminum-oxide abrasive is necessary for honing Nicasil as silicon-carbide is a part of the material and abrasives will not cut materials of similar density and composition.

We recommend using our Rod Honing Oil when working on Nicasil. The additives that make it ideal for high pressure honing also help the aluminum oxide abrasive cut cleaner and faster on a Nicasil surface.

If you have any other questions about honing Nicasil, be sure to call one of the Techxperts™ at Goodson 1-800-533-8010.

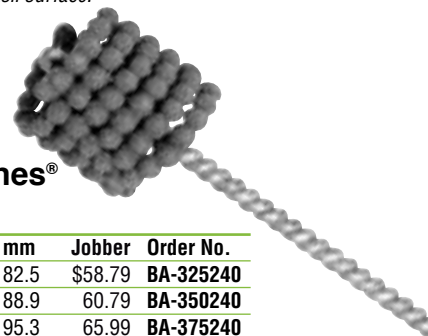

Standard Duty 240 Grit Aluminum Oxide Flex-Hones® Deglaze Nicasil Easily

Inch	mm	Jobber	Order No.	Inch	mm	Jobber	Order No.
2.25"	57.2	\$39.29	BA-225240	3.25"	82.5	\$58.79	BA-325240
2.37"	60.2	40.29	BA-237240	3.50"	88.9	60.79	BA-350240
2.50"	63.5	41.29	BA-250240	3.75"	95.3	65.99	BA-375240
2.62"	66.5	42.29	BA-262240	4.25"	107.9	73.29	BA-425240
2.75"	69.8	43.29	BA-275240	4.62"	117.5	78.29	BA-462240
3.00"	76.2	50.49	BA-300240				More Flex-Hones® on page 72



Guideless Stone Set for Nicasil

- Deglaze Nicasil cylinders with AN or HN hones • Use on cylinders with or without ports • Aluminum oxide abrasive • 150 grit • 2 stones per support • Resizing cylinders requires diamond abrasive

Range	Jobber	Order No.
2.5" - 3.3" / 64-84mm	\$37.29	GG25-A43
3.3" - 4.2" / 83-107mm	39.29	MM33-A43
4.0" - 5.6" / 102-142mm	41.29	NN40-A43



Replacement Parts for CV-616 Honing Machine

Replacement Belts	Jobber	Order No.
Timing Belt	\$129.29	CK-252
Flat Belt	61.79	CK-192A
"V" Belt, Upper	59.79	CK-209A
"V" Belt, Lower	36.49	CK-498A
"V" Belt, Blower	27.79	CK-1267A
Replacement Gear Set	55.79	CK-234A
Fiber planetary gear set for CV-616 and CK-10 handwheel assembly		



Hone Cabinet Filter Paper

- Reduce sump and filter clean-up
- Extend oil life • Filter paper in the bottom of hone machine removes debris before oil enters the sump
- When full, dispose of properly
- 2 - 60" x 60"/1524x1524mm sheets • Trim to fit
- Order No. **HN-FP** Jobber \$19.99

1" Thick Rod Hone Filter Mat

- Synthetic material
- Traps abrasive particles & metal filings BEFORE they enter the storage tank
- Cushions parts to prevent damage
- Replace when clogged • 1"/25.4mm thick

Inches	Metric	Jobber	Order No.
18"x25"	45.7x63.5 cm	\$15.99	RH-MAT
26"x40"	66.0x101.6 cm	24.99	RH-MAT-2
33"x48"	83.8x121.9 cm	25.99	RH-MAT-3

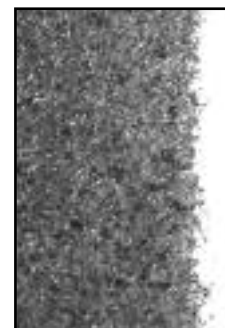

Cylinder Boring & Honing



Hone High-Silicon Aluminum Alloy Blocks With Ease – Honing Stones & Silicon Compound

These stones will fit both the Sunnen® AN-112 and AN-815 and the Goodson HN-218 and HN-218HD Portable Honing Mandrels. Use each stone set progressively until the final bore size is achieved. To create the final condition, coat the felt set and the honed cylinder surface with the Silicon Compound (AN-30) and lap the cylinders. After completion, the cylinder will have a dull matte finish and the piston and rings will ride on silicon instead of aluminum.

Learn more online at www.goodson.com/2012 or use your smart phone to scan this code for instant access to our instructions.



Description	Hone Dia. 2.5"-3.3"		Hone Dia. 3.3"-4.2"	
	Jobber	Order No.	Jobber	Order No.
Roughing (280 grit)	\$35.99	GG25-J65	\$37.29	MM33-J63
Finishing (400 grit)	35.99	GG25-J85	37.29	MM33-J85
Polishing (600 grit)	47.49	GG25-C05	45.49	MM33-C05
Felt Set	57.99	GG25-F05	61.79	MM33-F05
Silicon Compound	52.49	AN-30	52.49	AN-30



Mandrel Driver for Portable Hones

- For portable honing applications
- Ideal for spindle bushings mounted on axles and other jobs that can't be taken to the honing machine • For holes 3/4"/19.05mm ID and larger, where length is at least 3 times the diameter
- ID Range: .744" - 3.875"/19mm - 98mm
- Graduated adjustment knob advances and retracts stones
- Use with any 1/2"/12.7mm drill or larger • 275 - 450 RPM range • Use with CR- PL- and ML-series hones
- Order No. **GGN-150** Jobber \$677.99



Mandrel Driver for Align Honing Machines

- For Sunnen® CH-100 & similar align honing machines
- Graduated adjustment knob advances and retracts honing stones
- Quick release lever allows hone removal and installation without resetting
- Stone pressure adjusts with dial
- Automatically advances stones during honing
- **NOT** for portable honing applications
- Order No. **CH-75A** Jobber \$1,179.99



*Right Hand Rotation Only.
For best results, keep your RPM about the same as your hone RPM, use the same rate of speed and number of strokes.*

Ultra-Finish Plateau Soft Hones

- Remove microscopic peaks and scuffs without enlarging bores
- Use with a portable drill • Abrasive impregnated nylon bristles • Ideal for high-performance engine rebuilding and for newer style engines that use low-tension rings
- Use after honing cylinder bores
- Gives a superior plateau finish so rings seal immediately, reducing break-in time
- Small sizes ideal for valve guide work
- Allows closer tolerances for improved compression, better oil control, lower emissions
- For best results, use liberal amounts of honing oil (**HO-50**, pg. 73) • **NOT** interchangeable with Flex-Hones®

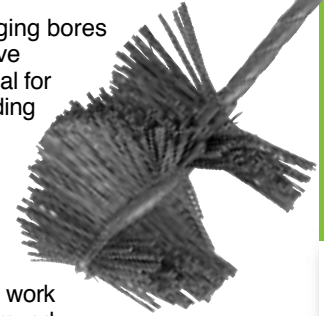

Hole Diameter	Hone	Head	Overall			
in	mm	Dia.	Length	Length	Jobber	Order No.
.2187"	5.5	.241"	1.00"	4.00"	\$ 9.29	UF-5.5MM
.2500"	6.4	.275"	1.25"	4.50"	9.29	UF-6.4MM
.2813"	7.0	.309"	1.25"	4.50"	10.29	UF-7MM
.3125"	8.0	.343"	1.25"	4.50"	10.29	UF-8MM
.3437"	9.0	.378"	1.25"	4.50"	10.29	UF-9MM
.3750"	10.0	.413"	1.25"	4.50"	10.29	UF-10MM
.4375"	11.0	.481"	1.25"	4.50"	10.29	UF-11MM
.4688"	12.0	.516"	1.25"	4.50"	10.29	UF-12MM
.5000"	13.0	.550"	1.50"	5.00"	11.49	UF-13MM
.5625"	14.0	.618"	1.50"	5.00"	11.49	UF-14MM
.6250"	16.0	.688"	1.50"	5.00"	11.49	UF-16MM
.6875"	17.5	.756"	1.50"	5.00"	11.49	UF-17.5MM
.7500"	19.0	.825"	1.50"	5.00"	11.49	UF-19MM
.8125"	20.5	.893"	1.50"	6.00"	11.49	UF-20.5MM
.875"-1.00"	22-25	1.250"	2.00"	10.00"	46.29	UF-100
1.00"-1.25"	25-32	1.500"	2.00"	10.00"	43.79	UF-125
1.25"-1.75"	32-45	2.000"	2.00"	10.00"	44.99	UF-175
1.75"-2.25"	45-57	2.500"	2.00"	10.00"	46.29	UF-200
2.25"-2.75"	57-70	3.000"	3.00"	10.00"	46.29	UF-250
2.50"-3.00"	63-76	3.500"	4.00"	14.00"	57.79	UF-300
3.00"-3.50"	76-89	4.000"	4.00"	14.00"	59.99	UF-350
3.50"-4.00"	89-102	4.500"	4.00"	14.00"	59.99	UF-400
4.00"-4.50"	102-114	5.000"	5.00"	14.00"	59.99	UF-450



Main Bore Align Hone Mandrels



- For the Sunnen® CH-100 Line Honing Machine
- Hone unit includes 1 set of 10 stones and 1 set of 20 shoes (replacement stones & shoes available)

Range	mm	Mandrels		Shoes (10/box)	
		Jobber	Order No.	Jobber	Order No.
2.4"-2.7"	61-69	\$2,479.29	10RY-2400G	\$66.99	RG-D
2.7"-3.0"	69-77	2,559.29	10RY-2700G	66.99	RG-D
3.0"-3.5"	77-89	2,579.79	10RY-3000H	73.29	RH-D
Stones 5/box		\$76.29	RY24-J49 (recommended for cast iron)		
fit all mandrels above		76.29	RY24-J45 (recommended for aluminum)		

More stones and shoes are available by special order, call to inquire.
1-800-533-8010

CYLINDER HEAD REBUILDING
CLEANING, ASSEMBLY & SAFETY
SHORT BLOCK REBUILDING
CRANKSHAFT/ FLYWHEEL GRINDING
BRAKE & ALIGNMENT TOOLS
MEASURING TOOLS
OFFROAD BIKE, ATV HARD PARTS
V-TWIN HARD PARTS

From our customers



"Fast and friendly service. Goodson has always been there for all our machine shop needs."
 - Brad Smith, Jenkins Automotive, Goshen IN, Goodson customer since 1984



Tech Tip Be sure to measure before you order. Belts stretch over time.

Goodson Belts & Feed Rods for Sunnen® Rod Honing Machines

• Top-quality for long life

Size	Jobber	Order No.
Oil Pump Belts (round)		
70"/1.78m	\$89.79	RHB-70
74"/1.88m	89.79	RHB-74
79"/2.00m	89.79	RHB-79
84"/2.13m	89.79	RHB-84
85"/2.16m	89.79	RHB-85
109"/2.77m	99.29	RHB-109
Flat Belts		
37 1/4" x 3/8" / 945.9 x 15.9mm	\$ 94.49	RHFB-37
45 1/2" x 3/8" / 1155.7 x 15.9mm	104.49	RHFB-45
46 1/2" x 3/8" / 1181.1 x 15.9mm	104.49	RHFB-46
Feed Rod Assemblies - Precision machined & assembled T6061 billet aluminum - For most discontinued models		
14" Bench Model	\$251.99	RHFR-14
16" Floor Model	251.99	RHFR-16



Honing Head for Rod Machines

- For small engines & removable cylinders
- Accurate to .0005"
- Fits most popular rod machines
- Ideal for small engines or those with removable cylinders such as air-cooled VW or motorcycles
- Uses Goodson HN or Sunnen AN-style honing stones (pg. 75)
- Order No. **AN-600**
Jobber \$895.99

Shown with optional honing stones



Rod Honing Oil

- Includes additives for high pressure cutting
- Keeps stones clean and free-cutting during rod reconditioning, pin fitting and other honing applications
- Will mix with other honing oils (including Sunnen®)

Size	Jobber	Order No.
1 gal./3.78L	\$ 28.99	RHO-10
5 gal./18.9L	124.99	RHO-50

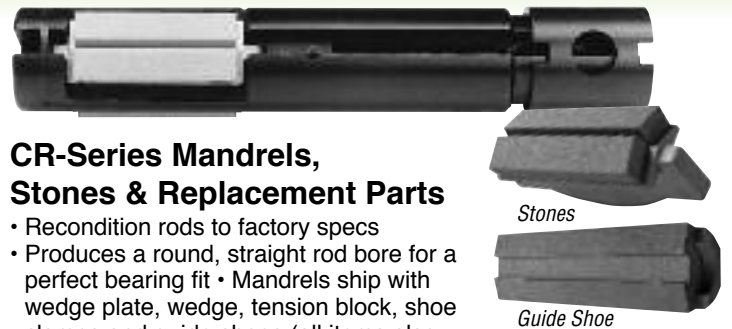

CR-Series Mandrels, Stones & Replacement Parts

- Recondition rods to factory specs
- Produces a round, straight rod bore for a perfect bearing fit
- Mandrels ship with wedge plate, wedge, tension block, shoe clamps and guide shoes (all items also available separately)
- Honing stones sold separately

CR Series Mandrels		Jobber	Order No.
Inch	mm		
1.45" - 1.60"	36.8 - 40.6	\$416.99	CR-1450
1.60" - 1.75"	40.6 - 44.4	416.99	CR-1600
1.75" - 1.90"	44.4 - 48.3	416.99	CR-1750
1.90" - 2.10"	48.3 - 53.3	474.29	CR-1900
2.10" - 2.30"	53.3 - 58.4	474.29	CR-2100
2.30" - 2.50"	58.4 - 63.5	489.99	CR-2300
2.50" - 2.70"	63.5 - 68.6	544.79	CR-2500
2.90" - 3.10"	73.7 - 78.5	611.29	CR-2900
Honing Stones			
Sunnen® Stones for CR-1450	Medium Finish	\$22.79	CR-2
to 1750 Mandrels (2/box)	Fine Finish	22.79	CR-4
Goodson Stones for CR-1450	Medium Finish	10.49	HC-2
to 1750 Mandrels (1/box)	Fine Finish	10.49	HC-4
Sunnen® Stones for CR-1900	Aluminum / Titanium	18.79	CR-9
& larger Mandrels (2/box)	Roughing	28.99	CR-10N
	Medium Finish	24.79	CR-12
	Fine Finish	24.79	CR-14
Goodson Stones for CR-1900	Roughing	12.79	HC-10
& larger Mandrels (1/box)	Finishing	11.79	HC-12
Sunnen® Guide Shoes (2 per box)			
Fit CR-1450 to 1750 Mandrel	Die Cast	\$12.49	CR-40D
Fit CR-1900 & larger	Die Cast	12.49	CR-50D
	Bronze	37.79	CR-50B
Goodson Guide Shoes (2 per box)			
Fit CR-1450 to 1750 Mandrel	Die Cast	\$ 8.49	C-40D
Fit CR-1900 & larger	Die Cast	8.49	C-50D
	Bronze	28.29	C-50-BR
Wedge & Wedge Plates			
Fit CR-1450 to 1750 Mandrel	Wedge	\$53.99	CR-70
	Small Plate	24.99	CR-75
	Large Plate	24.99	CR-85
Fit CR-1900 to 2500 Mandrel	Wedge	31.99	CR-100
Fit CR-1900 & larger	Small Plate	31.99	CR-110
	Large Plate	31.99	CR-120
Fit CR-2900 Mandrel	Wedge	45.49	CR-200
Tension Block			
Fits CR-1900 & larger		\$12.49	LN-1337A
Shoe Clamps (4 plus screws)			
Fits CR-1900 & larger		\$83.29	CR-45A



Rod Chamfer Cutters

Use in place of stone on CR-Mandrels to chamfer large ends

Fits CR-1450 to 1750	Cutter with tip	\$123.79	CR-35
Fits CR-1900 & larger	Cutter with tip	119.99	CR-25
	Replacement 3-edge Carbide Tip	47.49	CR-28A

Larger Mandrels, Stones and Replacement Parts are available by Special Order. Call 1-800-533-8010 for details.



CYLINDER HEAD REBUILDING

CLEANING, ASSEMBLY & SAFETY

SHORT BLOCK REBUILDING

CRANKSHAFT/ FLYWHEEL GRINDING

BRAKE & ALIGNMENT TOOLS

MEASURING TOOLS

OFFROAD BIKE, ATV HARD PARTS

V-TWIN HARD PARTS

Rod Honing Stones & Mandrels



KL-Series Lifetime Honing Units For Connecting Rods (Pin Fitting)

- Replaceable shoe means the mandrel never wears out
- Stone & Shoe are of proper length to produce straight, round, accurate holes
- Special orders are available, call 1-800-533-8010 for details

KL Mandrels (Order Truing Sleeve, Adaptor & Hone Stones separately)

		Mandrel Includes Wedge & Guide Shoes			Truing Sleeve many more sizes of sleeves in stock		Adaptor Includes Retainer		Guide Shoes (2) 1 set included with Mandrel	
Range (in)	(mm)	Jobber	Order No.	Sunnen® No.	Jobber	Order No.	Jobber	Order No.	Jobber	Order No.
0.775"-0.805"	19.7 - 20.4	\$87.79	KL-775M	AK20-775UA	\$16.49	S-775	\$33.99	AK20-A	\$36.29	UA-B
0.838"-0.868"	21.3 - 22.0	87.79	KL-838M	AK20-838UB	16.49	S-838	33.99	AK20-A	37.29	UB-B
0.869"-0.899"	21.1 - 22.8	87.79	KL-869M	AK20-869UB	16.49	S-869	33.99	AK20-A	37.29	UB-B
0.900"-0.930"	22.1 - 23.6	87.79	KL-900M	AK20-900UC	16.49	S-900	33.99	AK20-A	37.29	UC-B
0.962"-0.993"	24.4 - 25.2	87.79	KL-962M	AK20-962UC	16.49	S-962	33.99	AK20-A	37.29	UC-B
0.994"-1.062"	25.2 - 27.0	92.79	KL-1000M	AK20-1000UD	16.49	S-994	33.99	AK20-A	37.29	UD-B
1.056"-1.125"	26.8 - 28.6	92.79	KL-1062M	AK20-1062UD	16.49	S-1062	33.99	AK20-A	37.29	UD-B
1.181"-1.250"	30.0 - 31.7	92.79	KL-1187M	AK20-1187UE	16.49	S-1187	33.99	AK20-A	37.29	UE-B

NOTE: Sunnen® has changed their part numbers. We have listed the Sunnen industrial number to the right of our order number for your convenience.



Rod and Cap Grinding Wheels

- Recessed design
- Fits Sunnen® Rod and Cap Grinding Machines

Size	Jobber	Order No.
4"x1½"x1"	\$37.99	GR-305
101.6x38.1x25.4 mm		
6"x2"x1¼"	94.99	GR-805
152.4x50.8x31.8 mm		



Diamond Stone Dresser

- Diamond stone on durable metal tool
- Order No. **MAN-700**
Jobber \$79.29

Rod Honing Stones and Guide Shoes

- Premium-quality
- Choose Goodson or Sunnen®

Honing Stones	Use	Goodson			Sunnen®			
		Jobber	Order No.	Qty.	Jobber	Order No.	Sunnen No.	Qty.
For Sunnen® SL720 - SL2300 Mandrel								
	Roughing	\$10.49	HS-5	1	\$66.99	SL-5		6
	General Purpose	10.49	HS-7	1	66.99	SL-7		6
	Finishing	10.49	HS-13	1	66.99	SL-13		6
For Sunnen® PL Series Mandrel								
	Roughing	\$6.29	HP-5	1	\$69.99	PL-5	P28-J27	12
	General Purpose	6.29	HP-7	1	69.99	PL-7	P28-J47	12
	Finishing	6.29	HP-13	1	69.99	PL-13	P28-J67	12
For Sunnen® ML Series Mandrel								
	Roughing	\$5.99	HM-5	1	\$57.99	ML-5	P20-J25	12
	General Purpose	5.99	HM-7	1	57.99	ML-7	P20-J47	12
	Finishing	5.99	HM-13	1	57.99	ML-13	P20-J67	12
For Sunnen® KL Series Mandrel								
	Roughing	\$5.99	HK-5	1	\$58.79	KL-5	K20-J25	12
	Gen. Purp.	5.99	HK-7	1	58.79	KL-7	K20-J47	12
	Finishing	5.99	HK-13	1	58.79	KL-13	K20-J67	12
	Steel				58.79	KL-14	K20-A69	12
Bronze Guide Shoes		Jobber	Order No.	Qty.	Jobber	Order No.		Qty.
For Sunnen® KL and ML Series Mandrel								
	.775"- .805"	19.7-20.4mm	\$29.29	A-BMK	2	\$36.29	UA-B	2
	.838"- .899"	21.3-22.8mm	29.29	B-BMK	2	37.29	UB-B	2
	.900"- .993"	22.9-25.2mm		---		37.29	UC-B	2
	.994"- 1.125"	25.2-28.6mm		---		37.29	UD-B	2
	1.119"- 1.250"	28.4-31.8mm	32.99	E-BMK	2	37.29	UE-B	2
Note: Bronze guide shoes outlast die cast 6 to 1.								
Zinc Alloy Guide Shoes					Jobber	Order No.		Qty.
For Sunnen® PL and ML Series Mandrel								
	1.355" - 1.500"	34.4-38.1mm			\$18.79	WC-D		2
	1.480" - 1.625"	37.6- 41.3mm			18.79	WD-D		2



If you see something in the Sunnen® Engine Honing Equipment catalog that's not in the Goodson catalog, inquire about a special order.

Hydraulic Sleeve Installer

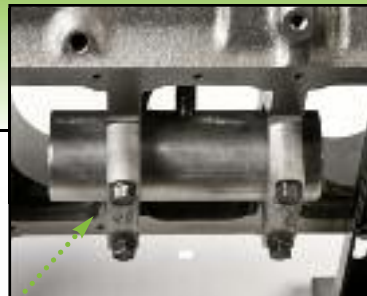

Install the anchor tube into the main bearing housing with the threaded hole facing the cylinder being sleeved. Install the threaded rod into the anchor tube through the center of the cylinder receiving the sleeve.

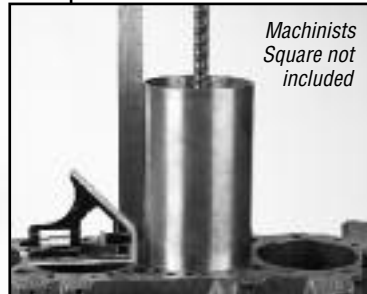

Machinists Square not included

The sleeve must be perpendicular to the block and in line with the cylinder. Measure to be sure.



Center the hydraulic ram over the sleeve. Lower the ram to the top of the sleeve, then thread the locking nut/washer onto the rod and snug it against the top of the ram assembly. Recheck to be sure the sleeve is still square to the block.

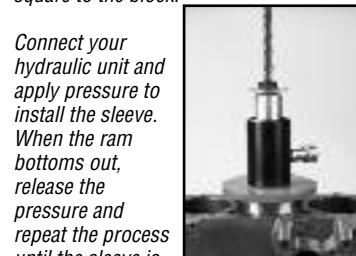

Connect your hydraulic unit and apply pressure to install the sleeve. When the ram bottoms out, release the pressure and repeat the process until the sleeve is fully seated in the block. The sleeve will move into the block approximately 1" at a time.

New!

Exclusive

- A: Hydraulic Ram
- B: Anchor Tube
- C: Heat Treated, Hardened Hold-Down Nut Assembly
- D: 28" L (nomial) Specially Heat-Treated, Hardened Threaded Rod

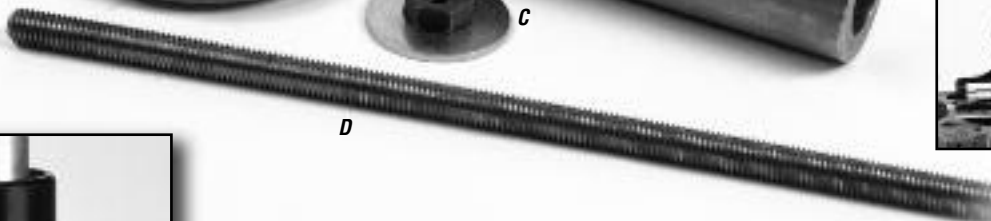
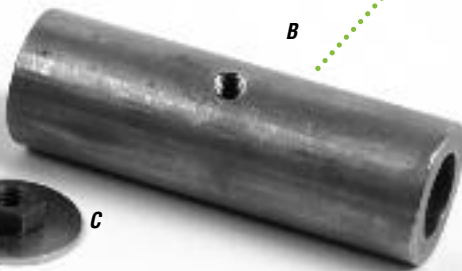

LEFT: Pioneer Quick Coupler 3000-2 is included with the kit for connection to your shop's Porta Power hydraulic pump or use your own 1/4" NPT fitting. Repair sleeves and Porta Power hydraulic pump are not included.

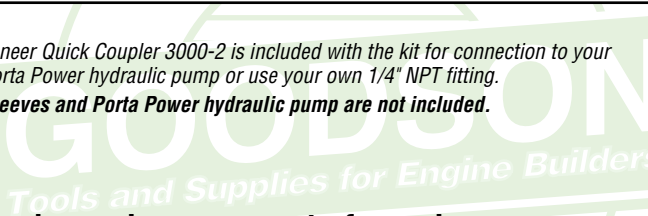

Protect expensive blocks and components from damage

You've invested a lot of time and money into your blocks. Why risk damage by banging a repair sleeve into a cylinder with a sledge-hammer? Use this Hydraulic Ram for controlled, easy repair sleeve installation. All you need is your Porta Power to easily install sleeves up to 5 3/4" OD.

Bring the press to the block not the block to the press

You'll never need to manhandle a cylinder block again to install repair sleeves! Connect your Porta Power hydraulic unit to this sleeve installer and you can generate up to 12 tons of force right on your bench.

Simple design and operation

The Goodson Hydraulic Sleeve Installer operation is anchored through the crankshaft centerline by installing the anchor tube. This provides a stable, secure platform for sleeve installation.

American Made

Ordering Information

Description	Jobber	Order No.
12 Ton Dry Sleeve Installer (pump not included)	\$529.99	GSI-12
Goodson Press Fit Lube (6 oz. Aerosol Can)	11.79	PFL-200

CYLINDER HEAD REBUILDING
CLEANING, ASSEMBLY & SAFETY
SHORT BLOCK REBUILDING
CRANKSHAFT/FLYWHEEL GRINDING
BRAKE & ALIGNMENT TOOLS
MEASURING TOOLS
OFFROAD BIKE, ATV HARD PARTS
V-TWIN HARD PARTS

Tapered Wrist Pin Bushing Press Kit

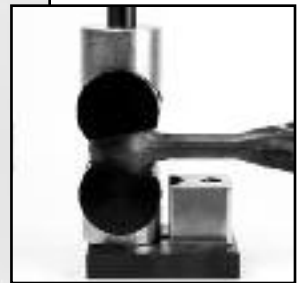

CYLINDER HEAD REBUILDING
CLEANING, ASSEMBLY & SAFETY
SHORT BLOCK REBUILDING
CRANKSHAFT/ FLYWHEEL GRINDING
BRAKE & ALIGNMENT TOOLS
MEASURING TOOLS
OFFROAD BIKE, ATV HARD PARTS
V-TWIN HARD PARTS

Tapered Pin Bushing Press Kit

This press kit is specially designed to remove and replace tapered bushings in most common diesel applications. Don't spend time making a fixture that's dedicated to a single size. Our Tapered Pin Bushing Press Kit is ready to go when you receive it. All you need is the correct bushing driver and you're ready to go.

Watch our Bushing Removal and Installation Videos online. Scan the code at right with your smart phone for instant access or go to:

www.goodson.com/TB-KIT



Description	Jobber	Order No.	Incl.
Complete Wrist Pin Bushing Press Kit	\$1,549.99	TB-KIT	▼
Wrist Pin Press Base (select drivers below)	899.99	TB-BASE	▼ x
Press Tube - Small (27x21x120mm)	59.99	TPT-SM	x x
Press Tube - Large (30x31x110mm)	59.99	TPT-LG	x x
Wrist Pin Ring (50x5x20/26mm)	13.99	WPR-001	x x
Wrist Pin Parallels (2) 8x10x50mm	27.99	WPP-2	x x
Wrist Pin Bushing Drivers sold by dimension, not application			
MM	Nominal	Actual	Step
25	1.000"	0.957"	0.063"
26	1.063"	0.990"	0.058"
27	1.060"	1.032"	0.067"
28	1.100"	1.006"	0.055"
30	1.180"	1.102"	0.075"
31	1.220"	1.158"	0.090"
31	1.220"	1.198"	0.067"
32	1.260"	1.222"	0.078"
33	1.300"	1.268"	0.068"
34	1.340"	1.304"	0.073"
36	1.420"	1.377"	0.075"
38	1.500"	1.458"	0.076"
40	1.570"	1.554"	0.068"
42	1.650"	1.614"	0.097"
45	1.770"	1.742"	0.089"
46	1.810"	1.772"	0.108"
50	1.970"	1.940"	0.083"
52	2.050"	2.012"	0.114"
54	2.130"	2.099"	0.081"
Press Fit Lube (6 oz. Aerosol can)	11.79	PFL-200	

How to determine the correct Bushing Driver

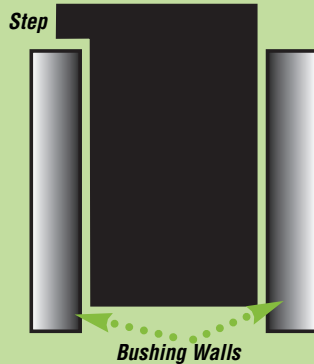

1. Measure the wrist pin diameter.
2. Select a driver from the chart at right that is .030" to .040" smaller.
3. Measure the thickness of the bushing.
4. Select the driver with a Step size that is 50% to 60% of the bushing thickness.

EXAMPLE:

Wrist Pin Dia. 1.185"
Nearest Driver Dia. 1.158"
Bushing Thickness 0.150"
40% of Thickness 0.090"

Select Bushing Driver **TBD-31**

If your measurements do not correspond to a driver in the chart, call 1-800-533-8010 to ask about a special order

Full Service ...FAST!!



"If you need engine building tools and supplies, you need Goodson! We're dedicated to providing you with the best quality products, the best value, the best information and the best service in the industry."
- Erik, Goodson Tech Services Department - 12 years of service

CYLINDER HEAD
REBUILDING
CLEANING,
ASSEMBLY & SAFETY

SHORT BLOCK
REBUILDING

CRANKSHAFT/
FLYWHEEL GRINDING

BRAKE & ALIGNMENT
TOOLS

MEASURING
TOOLS

OFFROAD BIKE, ATV
HARD PARTS

V-TWIN
HARD PARTS

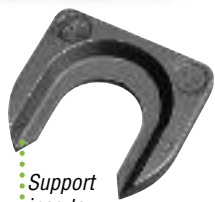

Support inserts keeps the connecting rod aligned properly. Several sizes are available.

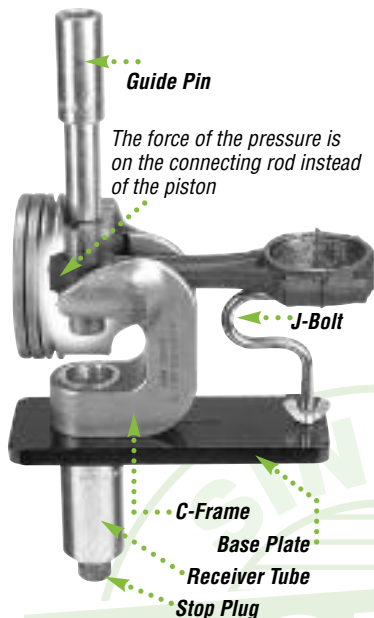

The force of the pressure is on the connecting rod instead of the piston

Piston Pin Removal Fixture

- Use to remove or install interference fit piston pins
- Force of removal is against the piston pin and connection rod – no pressure is exerted on the piston
- Tooled to fit most popular engines with pin diameters of 0.859" through 1.087" • Replacement Support Inserts and Guide Pins sold separately



For Small Block Chevy use Support Insert #1 or #6, for Big Block Chevy, use Support Insert #5

Description	ID	Thick	Jobber	Order No.	Incl.
Complete Kit			\$1,099.99	PPE-7082	▼
Replacement C-Frame			378.99	PPE-302186	x
Replacement Support Inserts	#1	0.945"	.100"	43.99	PPE-39889 x
	Blank #2	1.110"	.275"	43.99	PPE-39890 x
	#3	1.000"	.182"	43.99	PPE-39888 x
	#4	1.110"	.182"	43.99	PPE-39886 x
	#5	1.000"	.100"	43.99	PPE-39887 x
	Offset #6	0.945"	.100"	43.99	PPE-39822 x
Replacement Guide Pins	0.859"		\$39.29	PPE-17940	x
	0.897"		39.29	PPE-17936	x
	0.926"		39.29	PPE-17937	x
	0.970"		39.29	PPE-17938	x
	0.992"		39.29	PPE-17939	x
	1.032"		39.29	PPE-17941	x
	1.055"		39.29	PPE-17942	x
	1.087"		39.29	PPE-18729	x
Replacement Parts					
"J" Bolt (Rear Support)			\$25.99	PPE-302224	x
Wing Nut			1.29	PPE-10588	x
1 3/16"/30.2mm Stop Plug			51.49	PPE-17830D	x
Base Plate			79.79	PPE-17929	x
Receiving Tube			49.99	PPE-17931B	x
Body Guide			50.79	PPE-17932B	x
5 1/2"/139.7mm Spring			7.79	PPE-17934	x
Drift Pin Driver			25.79	PPE-17935	x
1 5/8"/41.3mm External Spiral Lock			10.99	PPE-17945	x

PPE-1GM-KIT



Universal Piston Pin Press-Out Tool

- Use with a shop press
- Top quality steel tooling
- Standard set handles most applications • You can modify for individual needs



Description	Jobber	Order No.	Incl.
Piston Pin Extractor Kit	\$229.99	PPE-1	▼
Rod Support Kit	79.99	PPE-1GM-KIT	▼
Piston Support Fixtures	.800" hole 22.79	PPE-1A	x
	.865" hole 22.79	PPE-1F	x
	.950" hole 22.79	PPE-1B	x x
	1.010" hole 22.79	PPE-1C	x
	1.010" hole 22.79	PPE-1D	x
	1.110" hole 22.79	PPE-1E	x
Fixture Base Block	32.99	PPE-1G	x x
Pin	.760" dia. 19.79	PPE-1H	x
Pressing	.812" dia. 19.79	PPE-1J	x
Drifts	.875" dia. 19.79	PPE-1K	x x
	1.000" dia. 19.79	PPE-1L	x
Tapped Handle	17.79	PPE-1M	x
Threaded Rod	8.29	PPE-1N	x
Threaded Adaptor	15.49	PPE-1P	x
Rod Support	18.79	PPE-1GM	x

GOODSON Rod Support for Sunnen® Pin Press Tooling

- Remove late model connecting rods from tapered boss pistons
- Aluminum construction prevents connecting rod damage
- Fits Sunnen® tooling

Description	Jobber	Order No.
GOODSON Rod Support	\$56.79	BRS-130
Sunnen® Reducing Ring	49.99	B-162

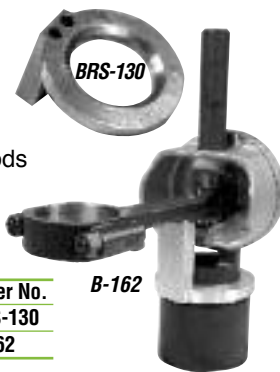

Minnesota Fast Freeze

- Instantly chills seats and guides to -50°F / -45.5°C
- Creates interference fit with heated aluminum heads • Finish seat and guide work faster than ever • Aerosol
- Use on tight bushings, pins, shafts, etc.
- Order No. **MFF-8** Jobber \$19.99



Buy 6 or more and save 10% off jobber





Determine the number of gas ports you will need and mark them at evenly spaced intervals on your piston. Measure the width of the ring groove and select the appropriate tool.

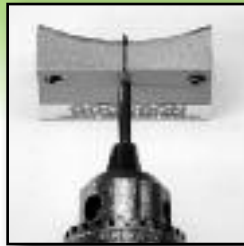

Insert the drill bit into the drilling fixture and slip on the depth gauge. Advance the bit until the very point of it shows on the curved side of the fixture. Chuck the bit into your drill.



Align the drilling fixture with your first mark. Use the set screws on the outer edges of the fixture to reduce any rocking or play that may occur.



Hold the piston, drilling fixture and drill firmly. Advance the drill bit just far enough to touch the back of the ring land. DO NOT drill beyond that point.

Gas Porting Tools for High Performance Pistons Give your customers' race engines the winning edge! Gas port high performance pistons for the ultimate ring seal.

You can virtually eliminate side ring clearance by drilling gas ports in your piston ring lands. These tiny ports apply compression pressure directly to the back of the ring pushing it against the cylinder wall with greater force while minimizing compression leakage. Gas ports work best with piston-compression heights of 1.2" or less on engines running at high rpm (7,000 or higher). These simple Tool Kits take all of the guess-work out of gas porting and include everything you'll need to get started. The complete kit includes: Drill Fixture, Depth Bushing and one Drill Bit.

US Patent No. US D617,664 S

Description	Size	Jobber	Order No.
Gas Porting Tool Kits	.043"	\$149.49	GPT-043
	.062" and 1.5mm	149.49	GPT-062
	.078"	149.49	GPT-078
Replacement Drill Bits (5 pack)	.040" for GPT-043	6.29	GPT-040-DB
	.062" for GPT-062 & GPT-078	6.99	GPT-062-DB

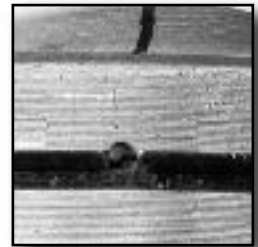

The image above is an example of what your gas port should look like when you're done. Repeat these steps at the remaining points you've marked.

Buy all 3 kits, save 10% off jobber! 

Band Ring Compressor Kits

- Install rings safely
- Hardened steel for durability
- Trigger ratchet mechanism for tight compressions



GPS-98A shown with GPS-98Q

Description	Jobber	Order No.	Incl.
6 Pc. Band Ring Compressor Kit	\$43.99	GPS-98	▼
9 Pc. Band Ring Compressor Kit	64.99	GPS-99	▼
Compressing Pliers	21.99	GPS-98A	x x
Bands Range	in. mm		
1.875" - 2.125"	47.63-53.98	\$11.99	GPS-98Q
2.125" - 2.375"	53.98-60.33	11.99	GPS-98R x
2.375" - 2.625"	60.33-66.68	11.99	GPS-98S x
2.625" - 2.875"	66.68-73.03	11.99	GPS-98T x
2.875" - 3.125"	73.03-79.38	11.99	GPS-98B x x
3.125" - 3.375"	79.38-85.73	11.99	GPS-98C x x
3.375" - 3.625"	85.76-92.08	11.99	GPS-98D x x
3.625" - 3.875"	92.08-98.43	11.99	GPS-98E x x
3.875" - 4.125"	98.43-104.78	11.99	GPS-98F x x
4.125" - 4.375"	104.78-111.13	11.99	GPS-98G x x
4.500" - 4.750"	114.30-120.65	12.99	GPS-98H
4.750" - 5.000"	120.65-127.00	12.99	GPS-98I
5.000" - 5.250"	127.00-133.35	12.99	GPS-98J
5.250" - 5.500"	133.35-139.70	12.99	GPS-98N
5.500" - 5.750"	139.70-146.05	12.99	GPS-98K
5.750" - 6.000"	146.05-152.40	12.99	GPS-98M
6.000" - 6.250"	152.40-158.75	12.99	GPS-98U
6.250" - 6.500"	158.75-165.10	12.99	GPS-98V

Piston Installing Deadblow Hammer

- 1-piece design • Specially formulated, urethane compound
- Convex-faced • Cut and split resistant • Non-mushrooming material • Offset head
- Ideal for fast, mar-free piston installation
- Weighs 1.7 lbs./.77 kg
- Order No. PK-200
- Jobber \$43.99

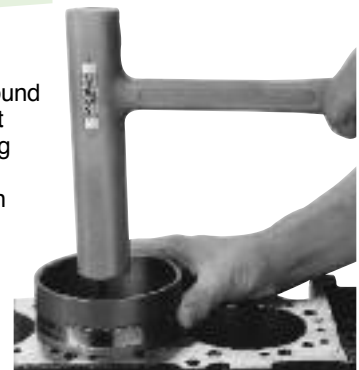

Piston Installing Sleeves

- Faster than a ring compressor • Tapered sleeve compresses rings as you drive in piston • Each has a .060" range • Adjust with a screwdriver • Durable, T-6 aluminum

Range in.	mm	Order No.
3.475"-3.575"	88.3-90.8	PRC-350
3.580"-3.675"	90.9-93.3	PRC-360
3.680"-3.775"	93.5-95.9	PRC-375
4.000"-4.120"	101.6-104.6	PRC-400
4.125"-4.225"	104.8-107.3	PRC-412
4.225"-4.345"	107.3-107.8	PRC-425

Jobber \$67.99



From our customers:



"All of the business I have done with Goodson has been excellent. My sales rep is very helpful, polite and courteous. My rating of her and your tech staff on a scale of 1 to 10 is a 12! Keep up the good work."
 - Richard Stokes, Carquest, Winchester, Virginia, Goodson customer since 1990

Diamond Dresser is securely held in place by the ring clamping pin



Easy to read integral dial indicator with dust boots

Powered Ring Filers

- No more tedious filing and rechecking to get desired end gap, set it once and cut multiple rings
- Easy to read integral dial indicator and positive ring stop make repeatable precision quick and easy
- Fits 2½"-5"/63.5-127mm diameter rings • High torque motor
- Adjustable guide holds rings square to the cutting wheel
- Table pivots past cutting wheel
- No open ways to gather grinding dust that causes premature wear
- Handy knurled in-feed adjustment knob

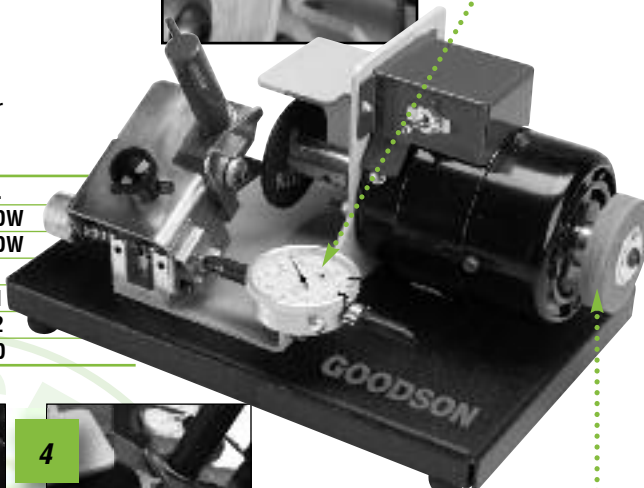

Description	Jobber	Order No.
Powered Ring Filer with Deburring Wheel 110V / 60 cycle	\$799.99	PRF-812DW
Powered Ring Filer with Deburring Wheel 220V / 50 cycle	829.99	PRF-822DW
Replacement Deburring Wheel	39.99	PRF-DW
2½" Replacement Grinding Wheel (60 grit) for pre-2008 models	8.79	PRF-1001
3" Replacement Grinding Wheel (60 grit)	8.79	PRF-1002
Replacement Diamond Dresser	25.99	PRF-812D

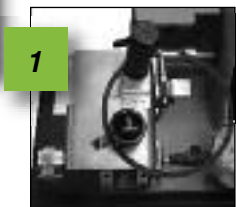

1 Stainless Steel Table



2 Eccentric adjusts quickly and easily



3 Positive ring stop



4 Table pivots past grinding wheel

Built-in deburring wheel eliminates the need to hand hone or deburr rings after filing

Manual Ring Grinder

- Produce end gap rings squarely
- Heavy duty aluminum casting
- Precisely machined for long life
- Silicon-carbide wheel holds shape and produces clean precise cuts • Unit includes 1 grinding wheel (replacements available)



Description	Jobber	Order No.
Piston Ring Grinder	\$99.99	PRF-250
Replacement Wheel	15.79	PRF-250W

Manual Ring Grinder

- Prevent damage to rings and cylinders • Measure ring gap then use this tool to grind it to the proper specifications quickly
- For any make, type or size rings
- Long-lasting metalized wheels are replaceable • Grinder includes one wheel



Description	Jobber	Order No.
Ring Grinder (includes 1 wheel)	\$109.99	PRF-870
Metalized Replacement Wheel	26.99	PRF-W
Premium Diamond Wheel	44.99	PRF-870-DW

Diamond Hand Files

- Make fine adjustments
- Choose between 360 & 600 grit
- Easily remove burrs created when end-gapping rings

Description	Jobber	Order No.
Diamond File Set - 1-360 grit & 1-600 grit	\$48.49	DFS-2
600 Grit Files (2-pack)	48.49	DFS-6



Fine Abrasive Stick

- Radiused for easier ring deburring after end gapping
- 4" L x ½" radius (101.6mm x 12.7mm)
- Works on all types of rings
- Works on ring ID radii
- Order No. **RS-103** Jobber \$19.99



Piston Ring Expander

- Remove & install most rings
- Tapered jaws
- ⅜" to ¼" 1.2mm to 6.35mm ring width
- Order No. **PRE-500** Jobber \$13.99



CYLINDER HEAD REBUILDING
 CLEANING, ASSEMBLY & SAFETY
 SHORT BLOCK REBUILDING
 CRANKSHAFT/FLYWHEEL GRINDING
 BRAKE & ALIGNMENT TOOLS
 MEASURING TOOLS
 OFFROAD BIKE, ATV HARD PARTS
 V-TWIN HARD PARTS

Electric Rod Heater

Exclusive New!



Worldwide Shipping

11 1/4"

Opening measures 2 1/8" to fit most standard rod eyes

Double-wall insulated heat chamber keeps the heat on the rod eye

Powder coated heavy gauge steel housing for long life

Includes Digital Timer & 450° Temperature Crayon



18 1/2"

Non-slip rubber feet provide stability

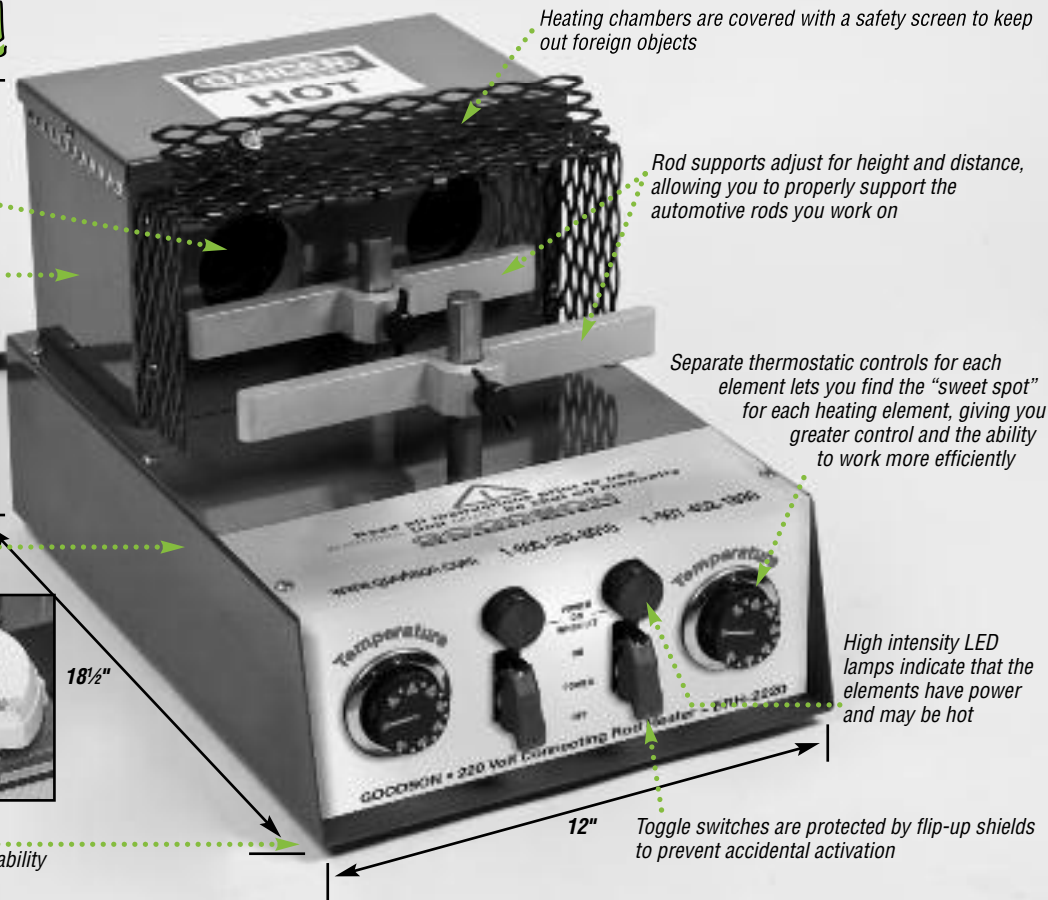

Heating chambers are covered with a safety screen to keep out foreign objects

Rod supports adjust for height and distance, allowing you to properly support the automotive rods you work on

Separate thermostatic controls for each element lets you find the "sweet spot" for each heating element, giving you greater control and the ability to work more efficiently

High intensity LED lamps indicate that the elements have power and may be hot

Toggle switches are protected by flip-up shields to prevent accidental activation

12"

See page 88 for gas unit.

Assemble Rods and Pistons Faster

This **NEW** Goodson Electric Rod Heater is designed to heat one or two connecting rods at a time. The twin 10 amp elements are double insulated to keep the heat focused on the rods. Coiled heating elements surround the connecting rod eye to heat more quickly without affecting the temperature of the entire rod.

High-output heating elements are included and require minimal pre-heating time. They operate between 140° and 750° F (60° - 399° C). For those who work in the Celsius scale, replacement knobs are included with the heater so you can easily change them.



Use with our Piston Pin Installing Fixture (PIF-25) sold separately (see page 88 for a complete description).

220 Volt, 50/60 Hz Single Phase Design – Compatible Worldwide

Every Goodson Electric Rod Heater comes with a "pig-tail" on the cord so that you can customize it to your required electrical hook-up. If you're hard-wiring the unit into your shop's electrical service, be sure to check with an electrical contractor and/or your local building codes.

View operating instructions online at www.goodson.com/ERH or scan the code at right with your smart phone for immediate access



Accessories

The Goodson Electric Rod Heater comes complete with a Digital Timer and 450° Temperature Indicator Crayon.

Fully Serviceable

This Electric Rod Heater is designed and built by Goodson and is available exclusively from Goodson, so you can be sure we'll have parts when you need them.

Ordering Information

Description	Jobber	Order No.
220V, 50/60 Hz Single Phase Electric Rod Heater	\$1,149.99	ERH-2220
Digital Read-Out Timer (battery included)	20.99	ERH-TIMER
Replacement Toggle Switch	19.99	ERH-SWITCH
Replacement Toggle Switch Guard	45.99	ERH-TSG
Replacement Thermostat	99.99	ERH-THERM
Replacement Coil	89.99	ERH-COIL
Replacement LED Light Assembly	49.99	ERH-LED
Replacement Bezel Knob	14.99	ERH-KNOB
Replacement Thumbscrew	6.99	ERH-TST
450° Melting Point Temperature Indicator Crayon	14.99	TIC-450
Piston Pin Installation Fixture	75.99	PIF-25

American Made

same day shipping

CYLINDER HEAD
REBUILDING

CLEANING,
ASSEMBLY & SAFETY

SHORT BLOCK
REBUILDING

CRANKSHAFT/
FLYWHEEL GRINDING

BRAKE & ALIGNMENT
TOOLS

MEASURING
TOOLS

OFFROAD BIKE, ATV
HARD PARTS

V-TWIN
HARD PARTS

Rod & Piston Work

CYLINDER HEAD
REBUILDING

CLEANING,
ASSEMBLY & SAFETY

SHORT BLOCK
REBUILDING

CRANKSHAFT/
FLYWHEEL GRINDING

BRAKE & ALIGNMENT
TOOLS

MEASURING
TOOLS

OFFROAD BIKE, ATV
HARD PARTS

V-TWIN
HARD PARTS

**Assemble
8 rods & pistons
in as little as
5 minutes**

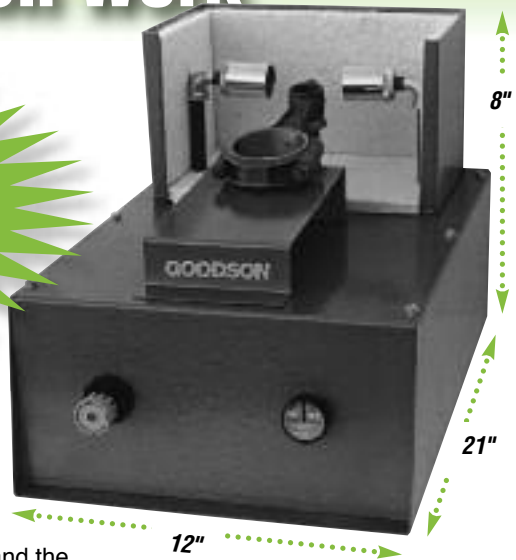

Gas-Fired Rod Heater

- Needs no warm-up time – you can start assembling rods and pistons almost immediately
- Heats piston pin ends so fast that the rest of the rod stays cool
- No cool down time after assembly and the operator doesn't need to wear gloves
- Ceramic lined enclosure contains flame keeping hands safe
- One knob controls the pilot and gas flow, another sets air flow for ideal combustion
- Burner lights easily with a striker (not included)
- No heat coils to burn out or circuitry to fail
- Includes one 600°F Temperature Crayon (see right)
- Propane model includes gas regulator and hose assembly
- Natural Gas model hooks up to your natural gas service

American Made

Description	Jobber	Order No.
Rod Heater for Propane	\$749.99	RH-50
Rod Heater for Natural Gas	749.99	RH-50N



**Buy 3,
get
10% off
jobber**

Temperature Indicating Crayons

- Mark the workpiece before heating
- Melts when temperature is reached
- 3 melting points to choose from

Melting Point	Jobber	Order No.
450°F/232.22°C	\$16.99	TIC-450
500°F/260.00°C	16.99	TIC-500
600°F/315.56°C	16.99	TIC-600

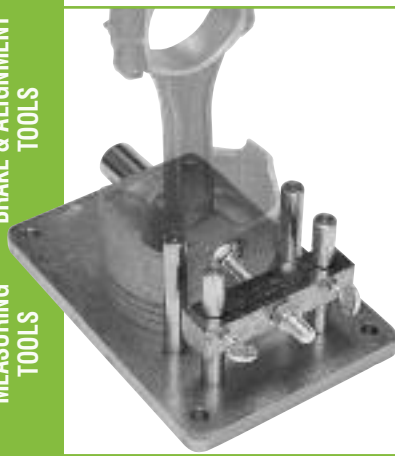

Piston Pin Installing Fixture

- Base is pre-drilled to mount to a workbench
- Adjustable stops prevent over-centering rods
- Adjust the stop once and you're ready to assemble a full set of rods
- Order No. **PIF-25**
Jobber \$75.99



Rod Bolt Boots

- Save crank journals from rod bolt damage
- Don't risk your reputation for quality • Plastic boots protect crank journals & rod bolts during piston installation • Reusable
- Set of 16
- Order No. **RBP-16** Jobber \$7.99

Rod Clamping Vise

- Align rods and caps perfectly
- Won't damage connecting rods like an ordinary vise
- Clamp rods firmly to align parting faces while torquing rod bolts
- Clamp in a vise or bolt to a workbench
- Order No. **RCV-20**
Jobber \$129.99

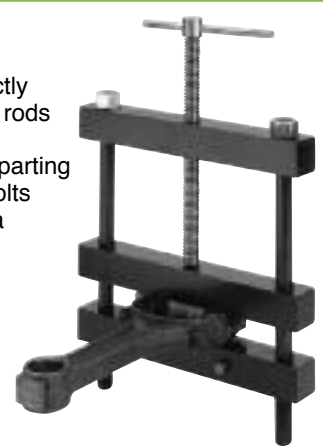

Heavy-Duty Rod Bolt Installing Block

- Mount universal block in a vise to support rod while installing bolts
- Hardened aluminum won't slip
- If the top wears, you can restore it with a file or belt grinder
- Ream holes larger to accommodate oversize bolts
- Order No. **RB-50**
Jobber \$36.99



Connecting Rod not included

Assembly & Break-In

5 Qt. Engine Pre-Lube Tank

- Air pressure pumps oil through lubrication system • Prevents dry starts • Cuts warranty claims
- Holds up to 5 qts./946.4mL of oil
- Uses 45 psi/310.3 kPa
- Kit includes tank, hose, fitting, valve and instructions
- Order No. **PL-40** Jobber \$199.99



Buy 12 or more and SAVE 10% off jobber!



Press Fit Lube

- A light coat eases press fit
- Ideal for valve guides, piston pins, cylinder sleeves, etc.
- Eliminates the scoring, gouging and galling of parts during press fitting
- 6 oz. (177.4mL) • Aerosol
- Order No. **PFL-200** Jobber \$11.79



CYLINDER HEAD
REBUILDING
CLEANING,
ASSEMBLY & SAFETY

SHORT BLOCK
REBUILDING

CRANKSHAFT/
FLYWHEEL GRINDING

BRAKE & ALIGNMENT
TOOLS

MEASURING
TOOLS

OFFROAD BIKE, ATV
HARD PARTS

V-TWIN
HARD PARTS



Extreme Pressure Lube

- Withstands pressures up to 50,000 PSI • Highly refined petroleum product • Contains no lead, graphite or minerals
- Won't corrode fine surfaces • Won't emulsify with cooling liquids • Surfaces stay lubed and protected
- In a grease form • 4 fl. oz.
- Order No. **EPL-4** Jobber \$7.99



Press Fit Lubricant

- A light coat eases assembly
- Multiple applications
- Eliminates scoring gouging and galling of parts during press fitting

Description	Jobber	Order No.
Aerosol 4.8 oz. (136g)	\$14.99	B-200
Brush Applicator 200 mL	22.79	B-200L



Break-In Lubricant

- Helps break-in and maintains ring seal on engine start-ups
- Apply to clean cylinder walls before final assembly with our non-abrasive pad
- Includes 1 oz./29.6 mL lube & 1 pad
- Replacements available

Description	Jobber	Order No.
Break In Lube	\$37.99	WSX
10 Pk. Non-Abrasives Pads	20.99	AHP-WHITE

Blood Friction Master® Engine Assembly Lube

- Contains Dupont® Teflon for dry start-ups
- Forms a slick wall between moving parts • Clings until dissolved by oil
- Withstands start-up pressure
- Compatible with all motor oils
- Ideal for high performance

Size	Jobber	Order No.
8 oz./236.6 mL w/brush	\$13.99	AL-22-8
1 gal./3.78 L w/pump	133.99	AL-22-10



Hi-Performance Break-In Lube



- Recommended as a break-in lube for all non-catalytic converter engine applications
- Not for use with synthetic oils
- Mix 3 oz. per quart of oil
- Replaces the zinc no longer included in most motor oils
- 16 oz./473 mL
- Order No. **EOT-16** Jobber \$23.99



First Lube Engine Assembly Lube

- Prevent dry engine start-ups after long-term storage
- Clings and forms a slick wall between moving parts
- Withstands start-up pressure
- Compatible with all motor oils

Size	Jobber	Order No.
8 oz./236.6 mL	\$6.99	FL-10
1 gal./3.78 L	29.99	FL-128



- Highly concentrated, won't dilute your engine oil, maintains the performance integrity of the oil
- Primary and secondary ZDDP for cold start to hot operation protection
- Race proven - NHRA, NASCAR, Indy, Formula One, etc.
- Essential for flat tappet cam engines
- Cannot be used on engines with catalytic converters



**Cam-Shield®
Anti-wear Oil Treatment**

- For racing & high-performance engines and valve trains
- Highly concentrated • Won't dilute engine oil
- Primary & secondary ZDDP for cold start to hot operation protection • Exact measure bottles remove guesswork!

Description	Jobber	Order No.
1-SHOT Regular (treats 4-6 qts.)	\$ 8.49	CSOT-15
3 oz. Measuring Bottle Racing (treats 8 qts.)	10.99	CSOT-3
8 oz. Measuring Bottle Regular (treats 16 qts.)	26.99	CSOT-8

Cam-Shield® Camshaft Assembly Lube

- Provides anti-wear protection for camshafts during break-in
- 2500 parts per million of Zinc
- Use with mechanical and hydraulic camshafts & lifters
- For racing, street, classic, agricultural, diesel and marine camshafts

Size	Jobber	Order No.
5/8 oz. Packet	\$ 3.29	CSAP-625
4 oz. Brush Top Jar	16.99	CSAP-4

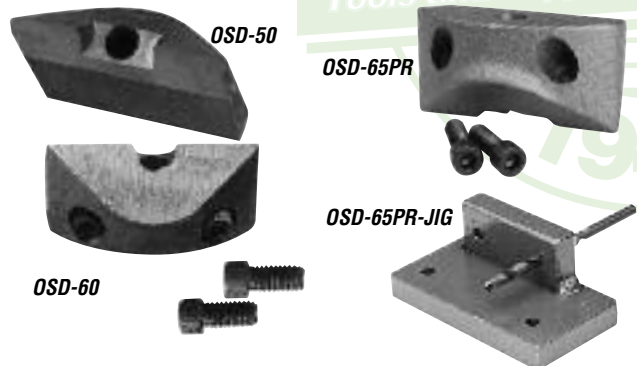

Oil Dipstick Conversion Parts

- Move the oil dipstick to the other side on Chevy 305/350
- Cut inventory – stock one type of block
- Improve quality – heavier, early-model blocks for late-model rebuilds

Description	Jobber	Order No.
Weld-On Casting for Chevy 305/350	\$10.99	OSD-50
Bolt-On Casting for Chevy 305/ 350 Drill and tap, then bolt the casting on. Bolt holes 1.5" on center. Bolts included.	10.99	OSD-60
Bolt Onto Pan Rail for Chevy 305/350 Reduces coolant leak risk. Bolt holes. 1.5" on center. Bolts included.	10.99	OSD-65PR
Chevy Pan Rail Jig for 305/350	99.99	OSD-65PR-JIG

Our most popular conversion

Order 6 or more castings (mix & match), Save 10% off jobber!



**Oil Filter
Inspection Tools**

- Check for contaminants with every oil change • Cutter opens the canister quickly for inspection
- For 2½" to 6½"/63.5 to 165.1mm diameter filters • Includes two blades



Description	Jobber	Order No.
Automotive Filter (female thread) Tool	\$89.99	FIT-1
Replacement Blade	11.29	FIT-W

**Oil Pump
Pickup Tube Driver**

- For all GM pumps
- Replace pickup tubes easily with a light mallet • Driver grips the pickup tube flare • Gives control for fast alignment and installation



Application	Tube OD	Jobber	Order No.
Small Block	5/8"/15.9mm	\$32.99	TI-25
Big Block	3/4"/19.1mm	32.99	TI-30

Oil Gallery Plug Removers

- Power plugs out with an impact wrench
- Threaded plug inside prevents bit from backing into the holder • ½"/12.7mm drive – fits impact wrenches
- Hardened tool-steel holder with lifetime breakage guarantee • Tool-steel bit can be reground or replaced
- Set screw holds bit firmly in place

Description	Size	Jobber	Order No.	Incl.
Plug Remover Kit	in mm	\$144.99	PPS-KIT	▼
Replacement Tool	3/16" 4.76	39.99	PPS-187	x
	1/4" 6.35	39.99	PPS-250	x
	9/32" 7.14	41.99	*PPS-281	x
	5/16" 7.94	39.99	PPS-312	x
	3/8" 9.53	39.99	PPS-375	x
Replacement Bits	3/16" 4.76	11.49	PPS-187B	
	1/4" 6.35	11.49	PPS-250B	
	5/16" 7.94	11.49	PPS-312B	
	3/8" 9.53	11.49	PPS-375B	

NOTE: *No bit is needed for PPS-281 (square socket).



Cylinder Block Work



Pin Pal Puller

- Remove dowels fast
- Adjusts to pull all sizes of dowels
- Vise-grip jaws hold firm while 4 lb. slide hammer forces dowels out
- Also pulls pressed-in hollow tubes or frozen shafts
- Rugged steel construction



Description	Jobber	Order No.
Complete Tool	\$289.99	GA-300
Replacement Jaws	80.29	GA-300E-R

It is essential, when pulling a dowel that the tightening sleeve is installed with the flared end toward the collet. This will allow the tightening sleeve to slide over the collet, locking it to the dowel you are removing. Also, be sure to select the correct collet size for the dowel you are removing.

Dowel Puller and Collets

- Slide hammer action removes stubborn dowels
- Use on blocks, heads, flywheels, etc.
- Split collets grip firmly without causing damage • A high-quality tool that lets you reuse dowel pins • Two kits available - US standard and metric
- All items also sold separately

Description	Jobber	Order No.	Incl.
Standard Kit	\$189.99	GA-600	▼
Metric Kit	189.99	GA-600M	▼
Slide Shaft	12.49	GAO-1	x x
Slide Hammer	21.99	GAO-2	x x
Tightening Sleeve	34.99	GAO-3	x x
Gripping Collets			
OD	ID	mm	
1"	.1575"	4.00	\$34.99 GAO-22 x
1"	.1875"	4.76	34.99 GAO-4
1"	.1969"	5.00	34.99 GAO-13 x
1"	.2362"	6.00	34.99 GAO-14 x
1"	.2500"	6.35	34.99 GAO-5 x
1"	.2756"	7.00	34.99 GAO-26 x
1"	.3125"	7.94	34.99 GAO-6 x
1"	.3150"	8.00	34.99 GAO-10 x
1"	.3750"	9.53	34.99 GAO-7 x
1"	.3937"	10.00	34.99 GAO-23
1"	.4375"	11.11	34.99 GAO-8 x
1"	.4724"	12.00	34.99 GAO-24
1"	.5000"	12.70	34.99 GAO-9
1"	.5512"	14.00	34.99 GAO-25
1"	.5625"	14.29	34.99 GAO-19
1"	.6250"	15.88	34.99 GAO-20
1"	.6400"	16.26	34.99 GAO-15
1"	.6750"	17.15	34.99 GAO-11
1"	.6875"	17.46	34.99 GAO-17
1"	.7350"	18.67	34.99 GAO-12
1"	.7500"	19.05	34.99 GAO-18
1"	.8000"	20.32	34.99 GAO-16
Removal Basin	23.99	GAO-21	x x

Parts are stamped for easy identification & reordering



Oil Gallery Wax

- Preheat the part to be removed, apply wax to its base, allow to cool and remove the part
- Choose between wax sticks and blocks of beeswax



Description	Jobber	Order No.
Oil Gallery Wax - 6" sticks (10 pk.)	\$17.99	OGW-1
Beeswax Stick - 1" 3/4"x3"/25.4x19.1x76.2mm	4.99	BWS-1

Oil Gallery Plug Installer / Staker

- Set depth and lock plug in a single step
- Arbor nose aligns cup plug, then follows with two 180° staker lugs to set depth and lock oil gallery plug securely in place
- Order No. **ST-SB** Jobber \$39.99



Oil Gallery Plugs

- Replace lost or damaged originals
- 1/4"/6.35mm plugs • For use at the rear of Small Block Chevy oil galleries or other engines with similar size plugs • 25 per box
- Order No. **OP-250** Jobber \$7.99

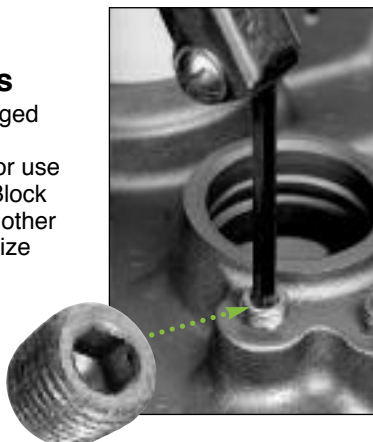

Small Block Chevy Deck Plug Kit

- 3/4" NPT cast iron plugs
- Help stabilize the critical deck area on Small Block Chevys
- Eliminates deck walk for better stability, ensuring a better ring seal
- **6-piece kit** Order No. **DPK-SB** Jobber \$21.99

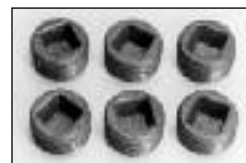

CYLINDER HEAD
REBUILDING

CLEANING,
ASSEMBLY & SAFETY

SHORT BLOCK
REBUILDING

CRANKSHAFT/
FLYWHEEL GRINDING

BRAKE & ALIGNMENT
TOOLS

MEASURING
TOOLS

OFFROAD BIKE, ATV
HARD PARTS

V-TWIN
HARD PARTS

Cylinder Block Work



NOTE: Wedges may come with a tab that must be removed BEFORE using them with the P-180 Head



Sunnen® Lifter Bore Hones

- Restore bore size and finish after shot blasting GM & Ford V-blocks
- Install oversize (Ford) lifters in GM engines for high-performance
- Stones work in cast iron bores or ones sleeved with brass or steel
- Wide stones contact a large area giving better stability for hand honing
- Cross oil ports without catching
- Wedge-type adjustment is a simple, positive way to expand or contract the stone to the precise size
- Use a 3/8"/9.5mm or 1/2"/12.7mm hand-held electric or air drill at approx. 200 RPM • Use with honing oil (page 73)
- **All parts MUST be ordered separately to make a complete unit**

Required Parts – fit any size Mandrel

Description	Jobber	Order No
Honall Head	\$286.49	P-180
Adaptor	59.99	PAK20-A
Roughing Stone (280 Grit) 12/box	86.99	Y20-J67
Finishing Stone (400 Grit) 12/box	86.99	Y20-J87

Standard Lifter Bore Tooling 6"/152.4mm Reach

Range		Mandrel		Wedge		Retainer		Truing Sleeve	
in	mm	Jobber	Order No.	Jobber	Order No.	Jobber	Order No.	Jobber	Order No.
.838"-.869"	21.2-22.1mm	\$346.79	AA Y20838BH6LH	\$56.79	Y20-W-6LH	\$35.99	LN-3688A-6LH	\$16.49	S-838
.869"-.900"	22.1-22.9mm	346.79	AA Y20869BH6LH	56.79	Y20-W-6LH	35.99	LN-3688A-6LH	16.49	S-869

Tall Deck Lifter Bore Tooling 6.75"/171.5mm Extended Reach

Range		Mandrel		Wedge		Retainer		Truing Sleeve	
in	mm	Jobber	Order No.	Jobber	Order No.	Jobber	Order No.	Jobber	Order No.
.838"-.869"	21.2-22.1mm	\$346.79	AA Y20838675LH	\$56.79	Y20-W-675LH	\$35.99	LN-3688A675LH	\$16.49	S-838
.869"-.900"	22.1-22.9mm	346.79	AA Y20869675LH	56.79	Y20-W-675LH	35.99	LN-3688A675LH	16.49	S-869



Manual Frost Plug Tool

- Minimizes the chance of frost plug distortion and leakage
- Two handle lengths – use the short handle for rebuild jobs, and the long handle for engines still in the vehicle
- Kit includes five sizes of installing plugs, ring nut and two steel handles • Replacement parts available – call for details • Order No. **FP-20** Jobber \$67.99

Rear Main Seal Holders and Alignment Pilot

RSH-PILOT

RSH-249

- Put old cranks in new blocks
- Adaptor enables the use of early 2-piece seal crankshafts in late model 1-piece seal blocks
- Precise alignment is mandatory and achieved with alignment pilot (sold separately)

Applications	Oil Pan	Jobber	Order No.
4.3L, 5.0L, 5.7L	Newer style	\$102.99	RSH-350
'86 and later	Early style	159.99	RSH-249
Alignment Pilot		31.99	RSH-PILOT

Lifter Bore Burnishing Tool

- Eliminates burrs caused by shotblasting
- Drive the burnishing tool into the bore with a soft hammer, then slide-hammer it back out • 60Rc burnishing balls deburr faster
- Won't oversize the bore

Description	Jobber	Order No.
Kit:	\$139.99	LBB-1500 ▼
Slide Shaft	12.49	GAO-1 x
Slide Hammer	21.99	GAO-2 x
Jam Nut	6.99	LBB-NUT x
Lifter Bore Burnishing Balls		
Set of 3 below	\$97.99	LBB-3SET ▼
GM .845" dia.	39.29	LBB-GM1 x
Ford .876" dia.	39.29	LBB-F01 x
Chrysler .906" dia.	39.29	LBB-CR1 x

Chevy Starter Drill Jig

- Drill & tap guide for perfect alignment
- For blocks missing inner mounting bolt hole necessary for use with mini starters
- Also use as a drilling and tapping jig for removing broken starter bolts
- Allows easy repair of the fastener holes • Use with standard drills and taps (not included) • 3 heat-treated tool/steel machining plates
- Order No. **SDJ-1** Jobber \$106.29



CYLINDER HEAD REBUILDING

CLEANING, ASSEMBLY & SAFETY

SHORT BLOCK REBUILDING

CRANKSHAFT/ FLYWHEEL GRINDING

BRAKE & ALIGNMENT TOOLS

MEASURING TOOLS

OFFROAD BIKE, ATV HARD PARTS

V-TWIN HARD PARTS

Camshaft Work

Whether you're regrinding cores for stock applications or custom grinding for diesel and high performance, you can count on Goodson Cam Grinding Wheels to deliver an excellent finish

Goodson abrasives are second to none. We work with our manufacturer to get you the most ideal grain that's bonded to be free-cutting, yet still shed before loading up. Our Premium wheels are ideal for steel high performance camshafts of 55 to 65 Rc and for Stellite overlays. Goodson makes all Camshaft Grinding Wheels to your specifications in-house for fast turn-around and delivery. Choose from the sizes below or custom order your cam wheel today!



Standard Cam Grinding Wheels - 100 grit					
Diameter	Width	Arbor	Jobber	Order No.	
Fits Storm Vulcan 75, 75D, 1165, 1165A					
18"	3/4"	19mm	3" 76mm	\$134.99	GCC 18 x 0.750 x 3
457mm	7/8"	22mm	3" 76mm	134.99	GCC 18 x 0.875 x 3
	1"	25mm	3" 76mm	134.99	GCC 18 x 1.000 x 3
	1 1/16"	27mm	3" 76mm	154.99	GCC 18 x 1.062 x 3
	1 1/8"	29mm	3" 76mm	154.99	GCC 18 x 1.125 x 3
20"	1 1/4"	32mm	3" 76mm	154.99	GCC 18 x 1.250 x 3
	7/8"	22mm	3" 76mm	204.99	GCC 20 x 0.875 x 3
	1"	25mm	3" 76mm	204.99	GCC 20 x 1.000 x 3
	1 1/8"	29mm	3" 76mm	204.99	GCC 20 x 1.125 x 3
508mm	1 1/4"	32mm	3" 76mm	204.99	GCC 20 x 1.250 x 3
	1 1/2"	38mm	3" 76mm	249.99	GCC 20 x 1.500 x 3

Due to the manufacturing process, actual colors may vary

Standard Cam Grinding Wheels - 100 grit					
Diameter	Width	Arbor	Jobber	Order No.	
Fits WVN 253, 254, 255 Peterson/Berco RAC-1500, RAC-2130					
18"	3/4"	19mm	6" 152mm	\$134.99	GCC 18 x 0.750 x 6
457mm	7/8"	22mm	6" 152mm	134.99	GCC 18 x 0.875 x 6
	1"	25mm	6" 152mm	134.99	GCC 18 x 1.000 x 6
	1 1/8"	29mm	6" 152mm	154.99	GCC 18 x 1.125 x 6
	1 1/4"	32mm	6" 152mm	154.99	GCC 18 x 1.250 x 6
20"	7/8"	22mm	6" 152mm	204.99	GCC 20 x 0.875 x 6

Green Silicon-Carbide Cam Grinding Wheels - 70 grit					
Fits Storm Vulcan 75, 75D, 1165, 1165A					
18"	7/8"	22mm	3" 76mm	\$299.99	GCW-181403
20"	7/8"	22mm	3" 76mm	299.99	GCW-201403
Fits WVN 253, 254, 255 Peterson/Berco RAC-1500, RAC-2130					
18"	7/8"	22mm	6" 152mm	\$299.99	GCW-181406
20"	7/8"	22mm	6" 152mm	299.99	GCW-201406

Torque-Angle Indicator

New Style

- When torque is given as degrees of turn past a certain ft./lb., use this gauge to show degrees
- 1/2" square drive
- Hold base with one hand
- Dial turns as you tighten
- Fits between a socket-driven extension and the socket
- Order No. **TQR-4554**
- Jobber \$19.99

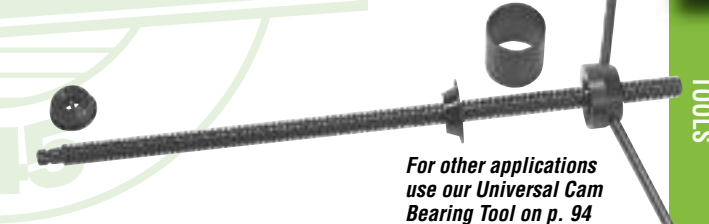

For other applications use our Universal Cam Bearing Tool on p. 94

Cam Bearing Removal & Installation Tool

- Never risk the accuracy of dimension or tolerances by hammering a bearing into place
- For caged needle bearing
- Drawing head has a captive thrust bearing to make the job effortless
- Remove or install bearings from one end of the engine block with the supplied tube
- Includes 1.968" needle bearing head, others sold separately

Description	Jobber	Order No.	Incl.
Cam Bearing Removal & Installation Tool	\$759.99	CBT-249	▼
Babbit Bearing Head			
1.875" 48mm	\$94.99	CBT-250	
1.968" 50mm	94.99	CBT-251	x
2.165" 55mm	94.99	CBT-252	
2.362" 60mm	94.99	CBT-253	
Standard Bearing Head	Application		
	Small Block Chevy	\$94.99	CBT-154
	Big Block Chevy	94.99	CBT-255
	Ford SVO	94.99	CBT-256
	GM-LS1	94.99	CBT-257

NOTE: Babbit Bearing Applications shown are the only ones available

Bore Washing Brushes

- Clean tunnel housing bores and full-annular grooved area
- Heavy, hand-driven shank

Bore Washing Brushes

Dia.	Length	Jobber	Order No.
2"	36"	\$17.79	CBB-200
2 1/4"	36"	20.79	CBB-225
2 1/2"	36"	21.79	CBB-250
2 3/4"	18 1/2"	21.79	CWB-27W
3 1/2"	18 1/2"	21.79	CWB-35
4"	18 1/2"	21.79	CWB-40
4 1/2"	18 1/2"	23.79	CWB-45



CYLINDER HEAD REBUILDING
CLEANING, ASSEMBLY & SAFETY
SHORT BLOCK REBUILDING
CRANKSHAFT/FLYWHEEL GRINDING
BRAKE & ALIGNMENT TOOLS
MEASURING TOOLS
OFFROAD BIKE, ATV HARD PARTS
V-TWIN HARD PARTS

From our customers:

"The quality of the tools and products I get from Goodson along with the prompt shipping and fine sales personnel have always been #1 with me. I've given out both Goodson's phone number and web address to many of my customers."

- Dave Yonemura, Felt Automotive Machine, Ogden, Utah. Goodson customer since 1990

CYLINDER HEAD
REBUILDING

CLEANING,
ASSEMBLY & SAFETY

SHORT BLOCK
REBUILDING

CRANKSHAFT/
FLYWHEEL GRINDING

BRAKE & ALIGNMENT
TOOLS

MEASURING
TOOLS

OFFROAD BIKE, ATV
HARD PARTS

V-TWIN
HARD PARTS

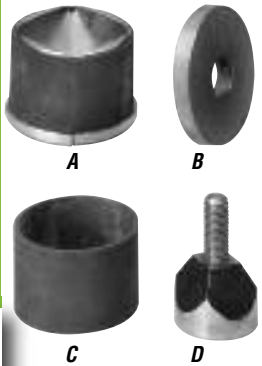
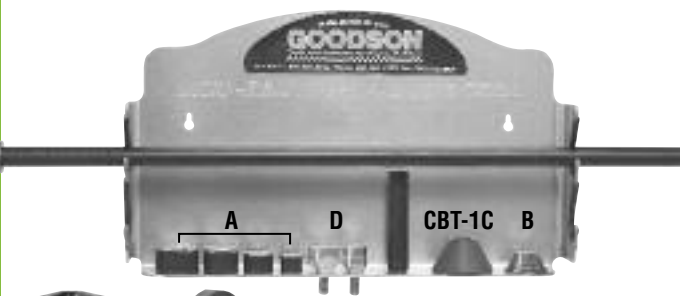

Brushed Aluminum Storage Rack
Included with kit purchase

Universal Cam Bearing Tool

- Remove and install hundreds of sizes of cam bearings with just four mandrels!
- Expanding Mandrels cover a 1.370"-2.250" range • Adjusts to undersize bearings so you can remove and install them from virtually any block
- Includes a free wall mount brushed aluminum storage rack
- Interchangeable with Dura-Bond

Description	Jobber	Order No.	Incl.
Universal Cam Bearing Tool			
Bearing Tool	\$449.99	CBT-300	▼
A-Replacement Segments with Sleeves			
Max 1.370"	\$52.49	CBT-5M	x
Dia. 1.682"	51.49	CBT-6M	x
1.875"	57.79	CBT-7M	x
2.250"	62.99	CBT-8M	x
B-Replacement Backing Plates			
Max 1.370"	\$13.79	CBT-5W	x
Dia. 1.682"	15.79	CBT-6W	x
1.875"	16.79	CBT-7W	x
2.250"	18.99	CBT-8W	x
C-Replacement Neoprene Sleeves			
Max 1.370"	\$ 6.29	CBT-5NS	x
Dia. 1.682"	8.49	CBT-6NS	x
1.875"	8.49	CBT-7NS	x
2.250"	10.49	CBT-8NS	x
D-Drivers			
Long 5"	\$49.49	CBT-1B	x
24"	115.49	CBT-2B	x
36"	129.79	CBT-3B	x
48"	139.99	CBT-4B	x
Miscellaneous Replacement Parts			
1 1/8" Expander	\$53.29	CBT-3E	x
1" Expander	50.49	CBT-4E	x
1/2"x13 Stud	10.99	CBT-1S	x
Guide Cone	29.49	CBT-1C	x
Threaded Impact Cap (New Style)	43.29	CBT-300-CAP	x

Lifting Sling

- Lift up to 1800 lbs./816.5 kg safely and easily
- 1" x 36"/25.4x914.4mm looped sling
- Secure the sling to the workpiece and move it with your overhead hoist
- Durable, nylon webbing
- Not for use with caustics or temperatures exceeding 190°F / 87.8°C
- Order No. **LS-3** Jobber \$10.99



DW-MK2



Degree Wheel

- Check cam timing, duration and overlap
- Degree wheel measures 11"/279.4mm dia. with 1 1/8"/47.6mm hole • Small ID Adaptor Kit mounts it to cranks using 3/8"- 3/4"/11.1-19.1mm fasteners or use the Turning Tool for that engine to mount the wheel
- Use the Briggs & Stratton Adaptor Kit for your kart engine
- Use with 1/2"/12.7mm drive ratchet

Wheel / Adaptors	Jobber	Order No.
Automotive Degreeing Kit	\$43.99	DW-KIT-2 ▼
Small Displacement Degreeing Kit for Briggs & Stratton	43.99	DW-KIT-1 ▼
Degree Wheel	\$32.99	DW-11 x x
Small ID Adaptor Kit	17.99	DW-MK2 x
Briggs & Stratton Adaptor Kit (not pictured)	13.99	DW-MK1 x
Degree Wheel Pointer	17.99	DW-11P x



Bearing Scraper

- Shave cam and babbitt bearing high spots
- Eliminate bearing high spots after installation to assure correct oil clearance
- Solid, wire wound, wood handle for strength and resistance to splitting
- 4"/101.6mm blade with 3 cutting edges
- Order No. **BS-30** Jobber \$21.99

Cam Bolt Locking Plate

- Keep timing bolts from backing out
- A hard to find item used to secure timing sprockets
- Ideal for small block, high-performance Chevys
- Order No. **CBL-9** Jobber \$2.99

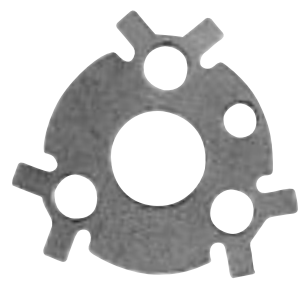

Full-service grinding wheel shaping, sizing and testing ... FAST!

Do you have a wheel that's too small for one machine but would fit another with some resizing or reshaping?

Goodson can enlarge IDs, reduce ODs, side dress, recess one or both sides, create hubs, recesses or special profiles, speed test and more in our full-service manufacturing facility. A tolerance of -.000" to +.015".

Improve final finish, grind with slotted wheels

Slotted crankwheels ease the flow of coolant to grinding surfaces, eliminating chatter and burning. Goodson can straight or angle slot your wheels.

For safety's sake let Goodson balance and speed test your wheels

Balancing: An out-of-balance wheel is dangerous to use and will produce an unusable result. Our technicians will balance your wheels to assure they operate safely.

Speed Testing: Rest assured that your wheels will perform at the speed you require. Our speed testing is ANSI compliant. Send us your wheels along with your speed testing specifications and we'll certify that it will operate safely. If it doesn't meet specs, we'll work with you to correct any problems.



RIGHT: Goodson's slicing machine can remove as little as .015" from your wheel.



Recycle your grinding wheels!

Goodson can resize your spent crankshaft grinding wheels so you can use them for another application.

It's easy!

It's fast!

It's economical!

It's good for the planet!

It's good for business!

Call 1-800-533-8010 today for more information!

GG-112

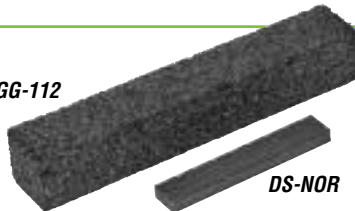

DS-NOR

Hand-Held Dressing Sticks

- Keep your crankshaft grinding wheels cutting clean

Description	Jobber	Order No.
1" x 1" x 6" • Hard Silicon-Carbide • Use to deglaze wheel side • Removes material with pressure	\$19.79	GG-112
¾" x ½" x 3" • Dense, granular Norbide®	59.99	DS-NOR
• For fine tuning radius and side relieving wheels		

Crank Grinding Coolant

- Formulated especially for crank grinding
- Semi synthetic
- Non-nitrite
- High-lubricity
- Dilute 20:1



Size	Jobber	Order No.
1 gallon (3.78 liters)	\$ 29.99	CGC-10
5 gallons (18.93 liters)	134.99	CGC-50

G-33



Diamond Crankwheel Dressers

- Choose standard grade or premium-grade with a harder diamond for improved performance and life

Shank Size	Carat	Standard Grade	Premium Grade
STORM-VULCAN 14, 15, 15A, 15C, 75, 75A			
½" x 3"	¾ ct.	\$124.99 G-25	
½" x 3"	1 ct.	179.99 G-25A	\$279.99 G-25AP
SCLEDUM (STEP-TYPE, STRAIGHT)			
10mm x 1 ¾"	¾ ct.	\$125.99 G-27	
10mm x 1 ¾"	1 ct.		\$283.49 G-27AP
10mm x 1 ¾"	1 ½ ct.	214.99 G-27B	409.49 G-27BP
PETERSON-BERCO			
Tapered, Step-Type 1 ct.		\$179.99 G-32A	\$279.49 G-32AP
Tapered, Step-Type 1 ½ ct.		279.99 G-32B	399.99 G-32BP
WINONA VAN NORMAN, LEMPCO, LANDIS (¾" HEAD)			
¾" x 1¼", 5/8" head ¾ ct.		\$169.99 G-30	
¾" x 1¼", 5/8" head 1 ct.		169.99 G-30A	\$283.49 G-30AP
¾" x 1¼", 5/8" head 2 ct.		299.49 G-30C	
SV & WVN CG-210,250,280 (RADIUS DRESSER)			
½" x 2" x 70°	¾ ct.	\$199.49 G-33	

See page 107 for our complete selection

**Full Service
...FAST!!**



"We're continually expanding our production department to provide more flexibility in grinding wheel shapes, sizes and profiles. Give us a call when you need something special."
- Orlo, Goodson Production Foreman - 27 years of service

Goodson crankwheels are made-to-order in-house

Other sources stock finished wheels, which makes it virtually impossible to stock a full size range. If they don't have what you need, they may charge more and delay your order for weeks. That's why Goodson makes every wheel to order. We always have the right wheel because we take a blank, size it, shape it, test it and ship it. Multiple wheel orders generally ship within approximately 72 hours.

For future reference write down your
Crank Wheel #

Grade x Diameter x Face Width x Arbor Size x Machine x Shape

Select the shape



Hub

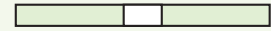

Straight

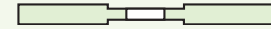

Recessed 2 Sides

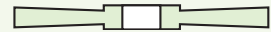

Tapered

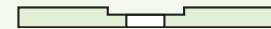

Recessed 1 Side

Select your wheel grade:

GCH Superior Grade - 54 grit

Better form holding ability, cuts cooler and needs less dressing. Use on crank journals with Rockwell hardness of 35 Rc or less. Use on crankshafts of Cast or forged steel, Nodular iron. Ideal for large radii, thrust and plunge grinding. Great for high-performance.

GCD Premium Grade - 60 grit

For harder materials. Good form holding ability; cuts cooler and needs less dressing. Grains yield faster, cooler grinding. Use on journals with Rockwell hardness of 35 Rc or more. Ideal for diesel, high-performance, industrial and billet steel.

Increase coolant flow with Crankwheel Slotting

Slotting facilitates the flow of coolant to the thrust and radii areas of the crank shaft. Don't waste time waiting on other suppliers who outsource their crankwheels for slotting – Goodson has the equipment in-house, so we can slot wheels in 48 hours or less!

How to order:

If you have any questions, please call 1-800-533-8010

Grade	Diameter	Face Width	Arbor Size	Machine	Shape
GCH - Superior	Diameters are available from 18" to 36" in most grades	Most sizes from 3/4" to 2 1/4" (custom widths are no extra charge)	Arbor size of your grinder. Any hole 3" to 12"	Identify the make and model of your grinder	We send the standard shape for your grinder unless you specify differently
GCD - Premium					

Enter your information below, then call Goodson at 1-800-533-8010 to order

GRADE X DIAMETER X FACE WIDTH X ARBOR SIZE X MACHINE X SHAPE

Please note, all wheels are delivered .015" oversize to allow for side dressing when mounting up

order at 1-800-533-8010 (outside the US & Canada, 1-507-452-1830) or online at www.goodson.com

From our customers



"We've been doing business with Goodson for several years. When we talk to our sales rep, it's like she's a part of the family. She knows us and cares about our needs, both professionally and personally and THAT means everything to us."
 - Ciara McCoy, Goodson customer since 2002

Plastigage

- Accurately measure bearing clearance
- Color coded by size • Put a piece on rod or main bearing and torque the cap • Remove and inspect • Width of crushed Plastigage shows clearance • Use at the workbench or in the vehicle • 10 per pack

Clearance Range	Jobber	Order No.
.001" to .003" / .025 to .076mm	\$21.99	PG-GREEN
.002" to .006" / .051 to .152mm	21.99	PG-RED
.004" to .009" / .102 to .229mm	21.99	PG-BLUE
10pk. Assortment (5 Green, 3 Red, 2 Blue)	21.99	PG-10PK

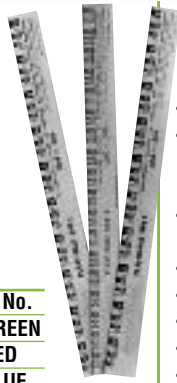

Hardness Tester

- Calculate Rockwell Hardness quickly and accurately
- Features a steel ball of precise weight and shape which is dropped from an exact height to yield an accurate Rc reading
- Check overheated or repaired crankshaft journals to confirm correct hardness
- Includes case & instructions
- Also use on flywheels
- Weighs just 4 oz.
- 9¼" long
- Order No. **HT-45RC** Jobber \$194.99

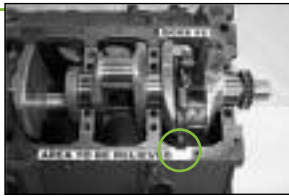
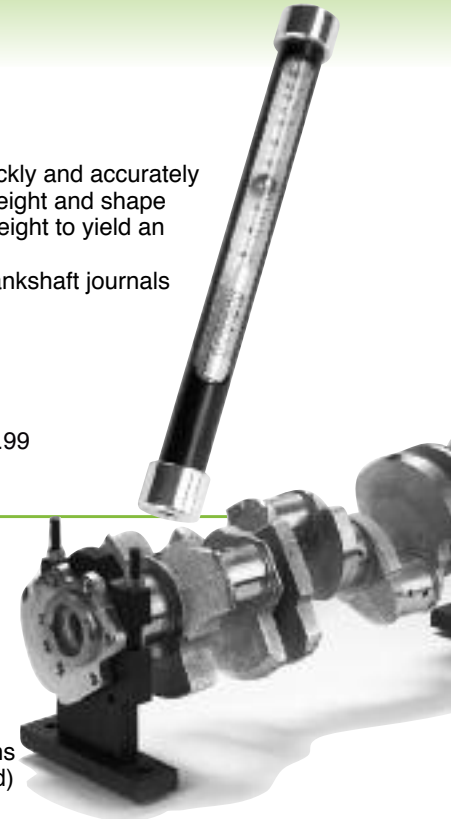

Create a relief in the block for rod #2 in at the pan rail area using your normal process (crank, rod, piston & bearing).



Place the arbor in main saddles #1 and #2, keeping the flange nearest to the pointer against main saddle #2.



Rotate the arbor and adjust the pointer in or out until the tapered end passes freely through the relief with a minimum of clearance.



Lock the pointer in position with the set screw and check the clearance again.



Once satisfied with the setting, scribe a line on the pointer opposite the set screw. Scribe or measure a different position for each new rod and stroke combination.

Stroker Mimic™

- Lightweight and easy to use
- Simple design
- Eliminates the need to repeatedly install and remove the crankshaft, pistons, the rod assembly and the necessary bearings when clearancing a block for a stroker crank
- Once the Stroker Mimic has been set to a particular crank, rod and piston combination, the tool can be marked or measured for future reference

Description	Jobber	Order No.
Stroker Mimic Fixture for 350 Blocks	\$159.99	SM-350
Replacement Pointer for SM-350	30.99	SM-351

Crankshaft Machining V-Blocks

- Use to cross-drill journals, keyway cutting, etc.
- Installs easily on Bridgeport-type machine with standard hold downs or bolts and "T" nuts (not included)
- Accepts diameters from 1" to 3¼"
- ¾" wide • Aluminum and steel construction
- Set up at ± .001" • 1 Pair
- Order No. **CVB-100** Jobber \$349.29

Stroke Checker

- Accurately measure strokes up to 6"
- Works with any precision caliper to accurately measure crankshaft strokes
- Measures strokes up to 6" with an accuracy of .001" • Rigid, hard-anodized aluminum frame is fully adjustable
- Fits almost any crankshaft
- Order No. **CSG-1** Jobber \$199.99

See page 122 for our selection of calipers

Shown with Mitutoyo® Digital Electronic Caliper Order No. **MEDC-06**



Crankshaft Peening Tool

- Designed for narrow Journals on some new style V6 crankshafts
- Peen crankshafts in the radius area of damaged journals to straighten
- Long-shank • Offset-radius face
- 10" long • 0.0625" radius
- 0.125" diameter
- Order No. **CPT-062** Jobber \$41.29

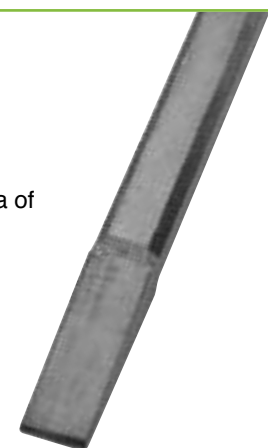

CYLINDER HEAD REBUILDING
 CLEANING, ASSEMBLY & SAFETY
 SHORT BLOCK REBUILDING
 CRANKSHAFT/FLYWHEEL GRINDING
 BRAKE & ALIGNMENT TOOLS
 MEASURING TOOLS
 OFFROAD BIKE, ATV HARD PARTS
 V-TWIN HARD PARTS

In-stock for immediate shipping!



Crankgrinder Steady Rest Shoes

- Perfect replacements for OE steady-rest shoes on most common machines
- If you can't find your shoe in our chart, fax us a photocopy of it for immediate identification (1-888-466-3909 or 1-507-452-2907) • Many more choices available by special order, call **1-800-533-8010** to inquire

Upper Shoe			Lower Shoe	
Thickness	OE No.	Order No.	OE No.	Order No.
PETERSON-BERCO				
5/16"		RBE-200		same as upper
SCLEDUM / DCM TECH				
1/4"	90069	RSC-237350N		same as upper
5/16"	90046	RSC-237350W		same as upper
STORM VULCAN				
3/8"	148-25	RSV-148025		
1/4"	15A-170-10	RSV-15A170	15A-170-9	RSV-15A179
3/8"	15A-70-10	RSV-15A710	15A-70-9	RSV-15A709
3/8"	15C-70-10	RSV-15C710	15C-70-9	RSV-15C709
SCHOU				
3/8"		RSC-15260		same as upper
WINONA VAN NORMAN				
475-477			111-5446	RVN-1115446
475-477	438-42	RVN-43842		
475-477	475-401	RVN-475401		
477	666-5418	RVN-6665418		
477			448-354	RVN-448354
WINONA VAN NORMAN / ZANROSSO				
250, 280	816130	RZN-2150		same as upper
MITO280	811365	RZN-2365		
250	811365	RZN-2365		same as upper
280	811365	RZN-2365		
210			815390	RZN-2390
250, 280	811410	RZN-2410	811411	RZN-2411
250	815801	RZN-2801	815802	RZN-2802

Jobber \$24.99 each Jobber \$24.99 each

If you can't find your shoe in our chart, fax us a photocopy of it for immediate identification. Toll Free Fax: 1-888-466-3909



Crankshaft Journal Radius Gauge

- 16 radii ... 1/32" to 1 7/64"
- Measure radii or reground journals quickly
- Blades are clearly marked in 1/64" increments
- Use in holder or remove
- Order No. **RG-16** Jobber \$27.29

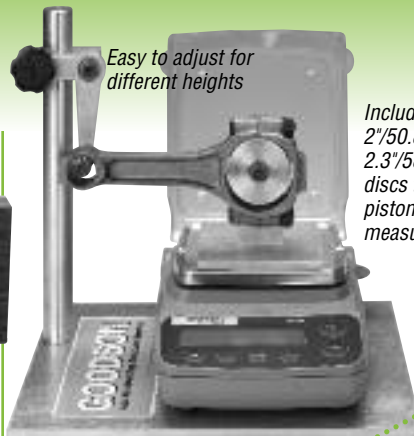

Easy to adjust for different heights

Includes 2"/50.8mm and 2.3"/58.4mm discs to support pistons while measuring

Flip-up cover protects scales when not in use

Large, easy to read digital display

Electronic Scales & Balancing Stand

- Ideal for static balancing parts
- Also use to weigh rotating and reciprocating masses and record the information for dynamic balancing • Scales feature automatic tare weight correction • Low battery indicator
- Easy to read digital display • Operates on 9V battery (not included) or 110V converter (included)

Capacity	Increments		Jobber	Order No.
	Gram	Ounce		
4100 Gram Scale	1.0	0.100	\$229.79	BS-200
5100 Gram Scale	0.1	0.001	499.99	BS-4800
Rod Balancing Stand			239.99	BS-201

Heavy Metal

An essential component when balancing rods & pistons to crankshafts to ensure proper engine operation.



HEAVY METAL - TUNGSTEN							
Hole in	Press Fit + in/mm	1.0" Long		1.2" Long			
		Grams	Jobber	Order No.	Grams	Jobber	Order No.
1/2"	.002"/.05	57	\$21.99	HM-57	65	\$23.99	HM-72
3/4"	.002"/.05	122	24.99	HM-122	147	34.99	HM-162
7/8"	.002"/.05	169	28.99	HM-169	198	44.99	HM-198
1"	.002"/.05	227	47.99	HM-227	265	54.99	HM-265

NOTE: Due to market fluctuations, heavy metal prices are subject to change without notice. Please confirm pricing when ordering.

Universal Quick-Set Crankgrinder Dial Indicator

- 3/8" diameter shaft • 12" long.
- .125" travel, .050" per revolution
- Rotating, lockable bezel graduated in .001" from -.025" to +.025"
- Order No. **MDI-12** Jobber \$299.99

More Dial Indicators on page 122



Starrett

CYLINDER HEAD
CLEANING, SAFETY
SHORT BLOCK REBUILDING
CRANKSHAFT/FLYWHEEL GRINDING
BRAKE & ALIGNMENT TOOLS
MEASURING TOOLS
OFFROAD BIKE, ATV HARD PARTS
V-TWIN HARD PARTS

**Full Service
... FAST!**



"If you're not sure what to order or if you have any questions, give us a call! We're here from 8am to 5pm Central Time, weekdays to serve you. We can help you get the most from our products and your equipment."
- Chris, Goodson ASE-Certified Master Machinist, 25 years of service



**SAVE 10%
off jobber!**
Order 5 or more boxes of crank polishing belts (any combination)

Outstanding flexibility! Belts conform to the crankshaft better.

Premium Ruby Crank Polishing Belts

- J-weight cloth-backing
- High strength mylar joint
- Phenolic resin-over-resin bond
- Polish better and outlast other standard polishing belts
- Aluminum oxide abrasive
- Color may vary due to manufacturing process

STRAIGHT-EDGE (10 per box) - Ruby							
Lgth	Wdth	240 grit	320 grit	400 grit	600 grit	800 grit	Jobber
60"	3/4"	R60x3/4x240	R60x3/4x320	R60x3/4x400	R60x3/4x600	R60x3/4x800	\$39.99
	1"	R60x1x240	R60x1x320	R60x1x400	R60x1x600	R60x1x800	39.99
64"	3/4"	R64x3/4x240	R64x3/4x320	R64x3/4x400	R64x3/4x600	R64x3/4x800	30.99
	1"	R64x1x240	R64x1x320	R64x1x400	R64x1x600	R64x1x800	39.99
	1 1/2"	R64x1 1/2x240	R64x1 1/2x320				37.99
	1 1/2"	R64x1 1/2x240	R64x1 1/2x320				42.99
	1 3/4"	R64x1 3/4x240	R64x1 3/4x320				49.99
72"	2"	R64x2x240	R64x2x320				56.99
	3/4"	R72x3/4x240	R72x3/4x320	R72x3/4x400	R72x3/4x600	R72x3/4x800	32.99
	1"	R72x1x240	R72x1x320	R72x1x400	R72x1x600	R72x1x800	33.99
	1 1/2"	R72x1 1/2x240	R72x1 1/2x320				43.99
	1 1/2"	R72x1 1/2x240	R72x1 1/2x320				45.99
77"	1 3/4"	R72x1 3/4x240	R72x1 3/4x320				51.99
	2"	R72x2x240	R72x2x320				58.99
	3/4"	R77x3/4x240	R77x3/4x320	R77x3/4x400	R77x3/4x600	R77x3/4x800	33.99
91"	1"	R77x1x240	R77x1x320	R77x1x400	R77x1x600	R77x1x800	34.99
	3/4"			R91x3/4x400	R91x3/4x600	R91x3/4x800	39.99
	1"		R91x1x320	R91x1x400	R91x1x600	R91x1x800	39.99

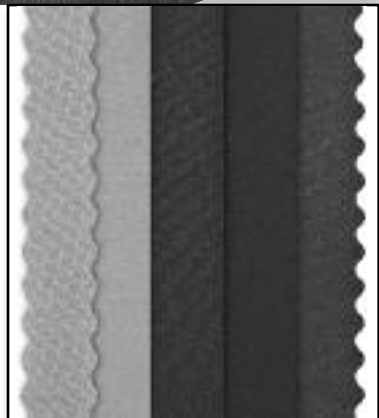

Try our Sample Pack!
Order No. **PCP-72PAK**
Jobber \$19.99

All abrasives are guaranteed for 1 year from the original purchase date

Premium Micro Polishing Belts

- Use with our polishing rouge
- 5 per box
- Structured Abrasive

Size (LxW)	Jobber	Order No.
60"x1"	\$36.49	GSW-60x1
64"x1"	36.49	GSW-64x1
70"x1"	36.49	GSW-70x1
72"x1"	39.99	GSW-72x1
77"x1"	39.99	GSW-77x1
Polishing Rouge	11.99	CPR-16



Structured Abrasive Crank Polishing Belts

- Outlasts most belts four to one
- Polishes to a high luster without removing material
- Finer than 400 grit
- Grains wear at a uniform rate for longer life • Generates less heat so expansion won't affect the finished journals • 5 per box



Size	Order No.
60" 3/4"	GSA-60x3/4
1"	GSA-60x1
64" 3/4"	GSA-64x3/4
1"	GSA-64x1
72" 1"	GSA-72x1
77" 1"	GSA-77x1
91" 1"	GSA-91x1

Jobber \$64.99

Scotch-Brite Style Abrasive Rolls

- Ideal for polishing high-performance crankshafts
- Non-directional polish
- Won't remove material
- Aluminum oxide abrasive with a high-strength resin bond
- Measure: 3/4"x10"



Description	Order No.
Micro-Finish	GFR-750
Super-Micro-Finish	SGFR-750

Jobber \$39.99

Display and Inspection Stand For Cranks & Cams

- Length adjusts 13" to 17" to fit journal spacing
- Rotate work to view or measure
- Durable hardwood ends won't scratch metal
- Welded frame • Plated finish
- Order No. **CIS-30** Jobber \$59.99

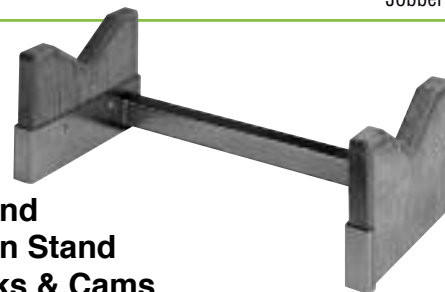

CYLINDER HEAD REBUILDING
CLEANING, ASSEMBLY & SAFETY
SHORT BLOCK REBUILDING
CRANKSHAFT/FLYWHEEL GRINDING
BRAKE & ALIGNMENT TOOLS
MEASURING TOOLS
OFFROAD BIKE, ATV HARD PARTS
V-TWIN HARD PARTS

**SAVE 10%
off jobber!**



Order 5 or more boxes of crank polishing belts (any combination)

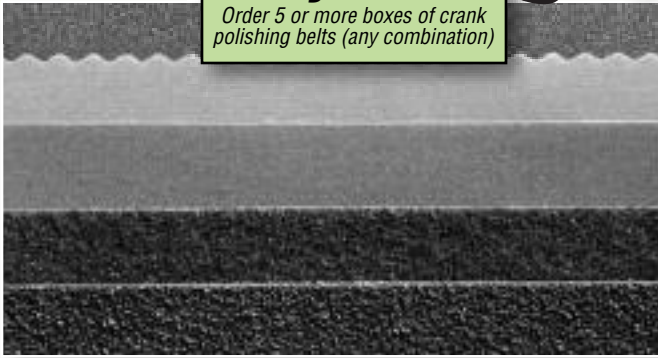

Crankshaft Polishing

Standard Polishing Belts

Good quality, flexible, woven cloth-back belts polish better and outlast other general-use belts. New belts can be used to remove minor journal damage without grinding while broken-in belts give a fine finish. Aluminum oxide abrasive. 2-layer glue bond. Colors may vary due to manufacturing.

STANDARD STRAIGHT-EDGE (10 per box) - Gray					
Length	Width	Jobber	240 grit	320 grit	400 grit
60"	3/4"	\$28.99		60x3/4x320	60x3/4x400
	1"	32.99	60x1x240	60x1x320	60x1x400
64"	3/4"	28.99	64x3/4x240	64x3/4x320	64x3/4x400
	1"	32.99	64x1x240	64x1x320	64x1x400
	1 1/2"	42.99	64x1 1/2x240		
	1 3/4"	38.99	64x1 3/4x240	64x1 3/4x320	
	2"	42.99	64x2x240	64x2x320	
70"	3/4"	31.99		70x3/4x320	
	1"	31.99	70x1x240	70x1x320	70x1x400
	1 1/4"	31.99		70x1 1/4x320	
72"	1/2"	23.99		72x1/2x320	72x1/2x400
	3/4"	32.99	72x3/4x240	72x3/4x320	72x3/4x400
	1"	32.99	72x1x240	72x1x320	72x1x400
	1 1/4"	44.99	72x1 1/4x240	72x1 1/4x320	
	1 3/4"	56.99	72x1 3/4x240	72x1 3/4x320	
	2"	59.99	72x2x240	72x2x320	
77"	3/4"	34.99		77x3/4x320	
	1"	34.99	77x1x240	77x1x320	77x1x400
	1 3/4"	59.99		77x1 3/4x320	
	2"	59.99		77x2x320	
91"	3/4"	35.99	91x3/4x240	91x3/4x320	
	1"	39.99	91x1x240	91x1x320	91x1x400
	1 1/4"	39.99		91x1 1/4x320	
	1 3/4"	53.99		91x1 3/4x320	
	2"	58.99		91x2x320	

All abrasives are guaranteed for 1 year from the original purchase date

Standard Scalloped Edge Crankshaft Polishing Belts

• 10 per box • 320 grit • 1" wide

Length	Jobber	Order No.
64"	\$34.99	S64x1x320
72"	35.99	S72x1x320
91"	56.99	S91x1x320



Store belts and abrasives in a dry moisture free area.

Fine finish

- Flexible, woven back • 2-layer resin bond • Aluminum-oxide • Very aggressive • Sharper grains cut faster without sacrificing finish • The Blue Backed Belt

Fine Finish (10 per box)					
Length	Width	Jobber	320 grit	400 grit	
60"	1"	\$36.99	G-60x1x320	G-60x1x400	
64"	1"	37.99	G-64x1x320	G-64x1x400	
72"	1"	39.99	G-72x1x320	G-72x1x400	
77"	1"	46.99	G-77x1x320	G-77x1x400	
91"	1"	42.99	G-91x1x320	G-91x1x400	



Scotch-Brite Style Micro Finish

- Rigid, 3-dimensional back • Resin bond • Aluminum-oxide abrasive • Non-directional finish

Micro-Finish (1 per box)				
Length	Width	Jobber	Order No.	
60"	3/4"	\$27.29	GF60-60 x 3/4	
	1"	28.29	GF60-60 x 1	
64"	3/4"	27.29	GF60-64 x 3/4	
	1"	29.29	GF60-64 x 1	
70"	3/4"	29.29	GF60-70 x 3/4	
	1"	33.29	GF60-70 x 1	
72"	3/4"	29.29	GF60-72 x 3/4	
	1"	31.29	GF60-72 x 1	
77"	1"	35.49	GF60-77 x 1	
91"	1"	39.79	GF60-91 x 1	



Scotch-Brite Style Super-Micro Finish

- Produces a mirror-like non-directional finish • Resin bond • Aluminum-oxide abrasive • For final finish

Super-Micro Finish (1 per box)				
Length	Width	Jobber	Order No.	
60"	3/4"	\$27.99	SGFB-60 x 3/4	
	1"	29.99	SGFB-60 x 1	
64"	3/4"	30.99	SGFB-64 x 3/4	
	1"	30.99	SGFB-64 x 1	
70"	3/4"	30.99	SGFB-70 x 3/4	
	1"	30.99	SGFB-70 x 1	
72"	3/4"	31.99	SGFB-72 x 3/4	
	1"	32.99	SGFB-72 x 1	
77"	3/4"	32.99	SGFB-77 x 3/4	
	1"	33.99	SGFB-77 x 1	
91"	3/4"	35.99	SGFB-91 x 3/4	
	1"	35.99	SGFB-91 x 1	



Abrasive Cork Super-fine Finish

- Satin finish • Won't disturb polished radii • Silicon-carbide

Abrasive Cork (1 per box)				
Length	Width	Jobber	Order No.	
64"	3/4"	\$19.99	CPB-64-3/4	
	1"	19.99	CPB-64-1	
70"	3/4"	19.99	CPB-70-3/4	
	1"	19.99	CPB-70-1	
72"	1"	19.99	CPB-72-1	
77"	3/4"	19.99	CPB-77-3/4	
	1"	19.99	CPB-77-1	
91"	3/4"	19.99	CPB-91-3/4	
	1"	19.99	CPB-91-1	



CYLINDER HEAD
REBUILDING

CLEANING,
ASSEMBLY & SAFETY

SHORT BLOCK
REBUILDING

CRANKSHAFT/
FLYWHEEL GRINDING

BRAKE & ALIGNMENT
TOOLS

MEASURING
TOOLS

OFFROAD BIKE, ATV
HARD PARTS

V-TWIN
HARD PARTS

IRON-CLAD satisfaction guarantee

Crankshaft Polishing

Tech Tip Extend the life of your polishing belts by releasing the tension when not in use.

Crankshaft Polishing Starter Kit

Includes 1 each of:
Grind Aid,
Polishing Rouge,
Abrasive Dresser and
5-Pack of our most popular
72" belts
Order No. **CP-KIT** Jobber \$52.99



Shown with flanged rollers

To keep motor operating efficiently, clean with compressed air regularly.

Includes 5 of our most popular 72" Belts (PCP-72PAK) A \$19.99 value



72" Crankshaft Polisher

- Flex resistant steel frame
- Weighs 15 lbs. (6.8 kg)
- Crowned rollers keep snug belt running true • 1" nominal = 1.625"
- 2" nominal = 2.625"

Roller Width		HP	Max. RPM	Jobber	Order No.
Nominal	Actual				
1"/25mm	1.625"/41mm	1/2	10,000	\$899.99	PCP-1072
2"/51mm	2.625"/67mm	1/2	10,000	939.99	PCP-1072-2

Replacement Parts and Rollers		Includes	
Flanged Roller Sets (3 piece set)	1"	\$144.99	PCP-1
Unflanged Roller Sets (3 piece set)	2"	164.99	PCP-2
Flanged Drive Roller	1"	50.49	PCP-1D
Fits 3/8" shaft - 1 ea.	2"	55.79	PCP-2D
Flanged Roller Assembly 3/8" x 16 thread - 1 ea.	1"	55.79	PCP-1F
Unflanged Roller Assembly 3/8" x 16 thread - 1 ea.	2"	78.29	PCP-2F
Bearing - 1 ea.		13.99	PCP-BRG
Replacement Switch		25.29	PCP-SWITCH-72
Replacement Motor		599.29	PCP-MOTOR-72

220 Volt, 50 cycle Motor Export Model

Roller Width		HP	Max. RPM	Jobber	Order No.
Nominal	Actual				
1"	1.625"	1/2	10,000	\$899.99	PCP-1072E
2"	2.625"	1/2	10,000	899.99	PCP-1072-2E
Replacement Motor				599.29	PCP-1072E-M

Grind Aid

- Cools and lubricates
- Reduces loading-up and grain fracturing
- Belts produce a better finish & last up to twice as long • Use only on cloth-back belts such as our Standard Polishing Belts on page 101
- Order No. **GRA-10** Jobber \$17.49

Polishing Rouge

- Produces high luster finish
- Use with light pressure, for cork or fine grit polishing to finish crank journals perfectly
- White • 16 oz. / 454 g
- Order No. **CPR-16** Jobber \$11.99

Abrasive Dresser

- Prolongs belt life • Hold at 45° angle on moving belt to remove foreign material • Restores cutting ability of grains
- 2" x 2" x 4" / 51 x 51 x 102mm
- Order No. **ACB-224** Jobber \$17.99

Heavy Duty Steel Stamps

- For hard materials • Order in sets or individually • For a single stamp, state character desired after Order No.
- Example: **SCH-1/4(A)** Single Character stamp, 1/4" size, Letter "A"



Number Sets				
Char. Size	Shank Size	Jobber	Order No.	
1/8"	5/16"	\$43.99	SFH-1/8	
3/16"	3/8"	47.99	SFH-3/16	
1/4"	7/16"	54.99	SFH-1/4	
Single Characters				
3/16"	3/8"	\$8.99	SCH-3/16	
1/4"	7/16"	8.99	SCH-1/4	

Special and custom orders are available, call 1-800-533-8010

Crank Welding Plugs Save Oil Holes When Welding Crankshafts

- 3 sizes available • Fits most common crankshafts • 100 per package



Small		Large		Order No.
End in/mm	End in/mm	Lgth. in/mm	Order No.	
.105"/2.7	.250"/6.4	.400"/10.2	CWP-100	
.190"/2.8	.285"/7.2	.300"/7.6	CWP-200	
.240"/6.1	.375"/9.5	.450"/11.4	CWP-300	

Jobber \$24.99

CYLINDER HEAD REBUILDING
CLEANING, ASSEMBLY & SAFETY
SHORT BLOCK REBUILDING
CRANKSHAFT/ FLYWHEEL GRINDING
BRAKE & ALIGNMENT TOOLS
MEASURING TOOLS
OFFROAD BIKE, ATV HARD PARTS
V-TWIN HARD PARTS

Dampener Installer

- Install harmonic dampeners without thrust bearing damage
- Screw tool into hole in the crankshaft end • Use the nut and thrust bearing to draw the harmonic dampener onto the crankshaft snout
- Fits 7/16" x 20" and 1/2" x 20" holes • 3 piece set
- Order No. **DIT-2** Jobber \$65.99



All Steel Construction

Exclusive

Reluctor Ring Installation Tool

- Adjustable depth for popular flange widths
- Fits Generation III engines: 4.8/LR4, 5.3/LM7 and 6.0/LQ4
- Aligns GM# 12559353 & 12586768 Sensor Rings on the crankshaft in the correct phased position
- Indexes in dowel hole of flange to dowel hole in sensor ring



US PATENT NO. 7,716,827

Eliptibur Tool

- Fastest, safest way to chamfer crank oil holes
- Simplify deburring and chamfering of angularly drilled holes on cylindrical surfaces • Self-centering, spring loaded pilot
- Replaceable blades • Easily produces a chamfer of relative uniformity and depth • Includes one blade
- For 30Rc or softer crankshafts



Description	Jobber	Order No.
Eliptibur Tool	\$284.99	EBT-15
Replacement Blades	39.99	EBT-15B

Description	Jobber	Order No.
Reluctor Ring Installation Tool	\$195.79	RRJ-350
Temperature Indicating Crayon (450° F/232°C)	14.99	TIC-450

INSTALLATION TIP: Heat reluctor ring to 450°F (232°C) then slide it onto the casting. Be sure to deburr all components before beginning assembly. Any sharp edges will cause the reluctor ring to catch on the casting, making assembly impossible.

Flywheel Saver Shims

Many clutch linkages aren't adjustable, so you must return the flywheel friction surface to original position after resurfacing, or faulty clutch action and possible failure can occur. These shims solve the problem, letting you grind a flywheel instead of replacing it. Shims install between the crank flange and flywheel to compensate for .025" or .050" of grinding. [Download our shim guide at www.goodson.com](http://www.goodson.com) to see shims full size.

Description	Diameter	Thickness	Jobber	Order No.
Chrysler				
3.7 (225ci), 3.9 (238ci), 4.0 (Jeep), 5.2 (Jeep), 6.3 (383ci), 7.2 (440ci)		4.375"	◆ .025"	\$11.99 FSS-852-25
5.7, 5.9 (Diesel), 7.5 and 8.1 Liter Engines		5.125"	◆ .025"	FSS-810-25
shims have break-off tabs to FIR 4.316" & 3.750" ODs			◆ .050"	FSS-810-50
Ford				
1.6, 1.9, 2.0,2.3, 3.0, 3.3, 3.1,3.8, 3.9 (240ci), 4.1 (250 ci), 4.2 (255ci), 4.7 (289ci), 4.9 (300ci), 5.0 (302ci), 5.8 (351ci)		3.625"	◆ .025"	\$11.99 FSS-468-25
			◆ .050"	FSS-468-50
5.7 (352ci), 5.9 (360ci), 6.4 (390ci), 6.9 Diesel (420ci), 7.0 (427ci) 7.5 (460ci)		5.000"	.025"	FSS-460-25
General Motors				
2.0, 2.2, 2.5, 2.8, 3.1		3.000"	◆ .025"	\$11.99 FSS-628-25
			◆ .050"	FSS-628-50
2.3, 3.3, 3.7 , 3.8, 4.1, 4.3, 4.6, 5.0, 5.4, 5.7, 6.0, 6.2 Diesel,		4.500"	◆ .025"	FSS-857-25
6.5, 6.6 Diesel, 6.6, 6.7 (402ci), 7.0 (427ci), 7.4 (454ci)			◆ .050"	FSS-857-50
2.2, 2.3, 3.8, 4.3		3.750"	.025"	FSS-643-25
4.2, 4.8, 5.3, 6.0 and 6.6 (diesel)		4.056"	.025"	FSS-866-25
Honda				
1.2, 1.3, 1.5, 1.6, 1.8, 2.0, 2.1, 2.2, 2.4, 2.6, 2.8, 3.0, except V-6		3.125"	.025"	\$11.99 FSS-4025
Jeep				
2.5, 2.8, 3.1, 4.0 (GM Engine)		3.000"	.025"	\$11.99 FSS-628-25
			.050"	FSS-628-50

Note: Shims marked with this symbol (◆) in the table can be stacked to a total thickness of .075."

Others available by special order



**Full Service
... FAST!**



"Goodson accepts major credit cards, debit cards, bank drafts and personal checks. Call us for more information."
- Beverly, Goodson Accounting Department Manager - 29 years of service



Flywheel Radius Cutter Tip Holder For WVN/VN FG-5000

- Convenient and easy to use • When one cutter edge dulls simply turn to a new edge • Holder measures 1.5"/38.1mm long with a .312"/7.9mm diameter shank • Includes one indexable cutter tip

Description	Jobber	Order No.
Radius Cutter Tip Holder	\$121.79	FG-5011
Replacement Cutter Tip	9.49	FG-3B
Titanium Coated Replacement Cutter Tip	11.79	FG-3BT
Replacement Torx Screw	2.29	FG-8103

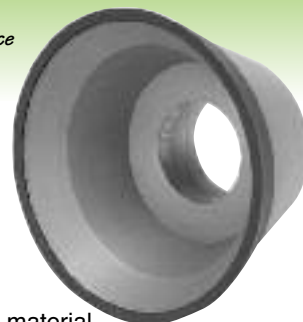

Standard 1 1/4" grinding arbor - no special adaptors required

CBN* Flywheel Grinding Wheels

- Aluminum core • 1/8" thick CBN material
- 1 1/4"/31.75mm arbor • Several sizes to choose from

Nominal Size & Description	Jobber	Order No.
3" diameter CBN wheel - straight sides	\$189.99	ECBN-300
4" diameter CBN wheel - flared sides	199.99	ECBN-4
6" diameter CBN wheel - flared sides	219.99	ECBN-6
CBN Dressing Stick - 1/2"x1/2"x6"	16.79	DS-CBN
Flywheel Grinding Coolant - 1 gallon/3.78L	41.99	FG-1101-G

* Cubic Boron Nitride

CYLINDER HEAD REBUILDING

CLEANING, ASSEMBLY & SAFETY

SHORT BLOCK REBUILDING

CRANKSHAFT/ FLYWHEEL GRINDING

BRAKE & ALIGNMENT TOOLS

MEASURING TOOLS

OFFROAD BIKE, ATV HARD PARTS

V-TWIN HARD PARTS

Flywheel Grinder Bolt Adaptors



FG-LOCK

- Replace shoulder bolts with standard hardware
- Low-cost adaptor converts any 1/2" or 7/16" bolt to a 3/4" ID
- Includes countersunk adaptor with bolts for extra clearance

Fits	Size	Jobber	Order No.
WVN	7/16" x 14	\$33.99	FG-AB-KIT
WVN Table Insert	OD: 5/8" x 11, ID: 7/16" x 14	6.79	FG-LOCK
DCM, Peterson, KW	1/2" x 13	33.99	FG-DCP-KIT

Flywheel Depth Gauge with Dial Indicator

- Measure flywheel before and after grinding to maintain proper depth specifications
- Spindle Extensions sold separately

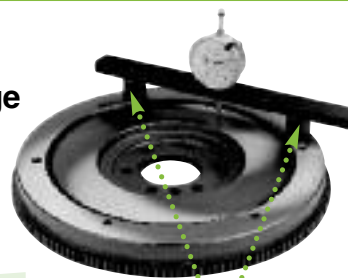

Magnetic feet adjust to flywheel diameter

Description	Jobber	Order No.
Gauge	\$136.99	FGG-12
Spindle 1.5"	7.49	DIS-1.5
Extensions 2.5"	9.99	DIS-2.5
3.0"	11.79	DIS-3.0



SAVE!

Order 5 or more, take 10% off jobber!

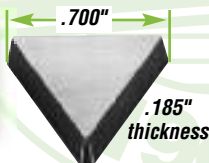

Flywheel Cutter Tip For Winona Van Norman 570 Rotary Broach

- 3-edge carbide cutting tip for use with the special flywheel attachment on the Winona Van Norman 570 Rotary Broach
- Order **VN-FW** Jobber \$13.99

Tech Tip

Be sure to use ample coolant to flush away swarf and help the stones perform better.



Flywheel Grinding Coolant

- Formula eliminates rancid coolant
- Synthetic inhibitors
- Dilute 30:1

Size	Jobber	Order No.
1 Gal./3.78L	\$ 41.99	FG-1101-G
5 Gal./18.8L	149.99	FG-1102-G

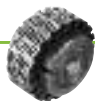

GS-10



GS-17A

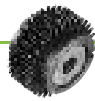

GS-17KW



FG-1165-G

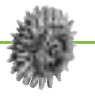

FG-1070A-G



FG-1045-G



GS-14



GS-17

Grinding Wheel Dressers & Replacement Cutters

Diamond Dresser tools available on page 106-107

Applications	Cutter Assemblies					Replacement Cutters				
	OD	ID	W	Jobber	Order No.	Pieces	Washers	Size	Jobber	Order No.
VN, Lempco, Storm RT-7Y, 17Y	2.500"	1.500"	.0625"	\$84.99	GS-10	14 stars	1 w/locking tangs	1.75" x .058"	\$21.99	GS-14
Peterson (12mm shaft)	2.375"	1.500"	.0938"	84.99	GS-17A	8 stars	5 1 locking	2" x 1.50" x .028" 1.75" x 1.5" x .06"	21.99	GS-17
Kwik-Way	2.375"	1.500"	.0938"	84.99	GS-17KW	8 stars	5 1 locking	2" x 1.50" x .028" 1.75" x 1.5" x .06"	21.99	GS-17
WVN SM2000, 4000, 5000, 6000C, 6000A, MG3000, 3850	1.250"	0.313"	.0625"	29.99	FG-1165-G	7 stars	none	1.25" x .313" x .095"	7.99	FG-1161-G
Peterson & DCM	2.375"	1.125"	.125"	63.99	FG-1070A-G	5 stars	1	1.624" dia. x .031"	15.99	FG-1070-G
Hand held				77.99	FG-1045-G	1 stone	none	1.500"x.313"x.625"	13.99	FG-1044-G

10% off jobber!

Order 5 or more flywheel grinding stones (any combination)

Flywheel Grinding Stones



Flywheel Grinding Stones

For best results... choose the right stone from Goodson

Goodson stones feature 50% more usable abrasive and much stronger construction, yet sell at prices comparable to ordinary stones. With Goodson stones you'll get longer wheel life and lower-cost flywheel grinding.

Cast Iron:

Cast Iron (soft) flywheels need to be ground with harder stones. Experiment to find the best stone. A good starting point is the **FGW-57**, our best all-around stone for Cast Iron.

Cast Steel:

Cast Steel (medium) flywheels require medium-hard stones. The **FGW-65** is our best all-around stone for Cast Steel.

Billet Steel:

Billet Steel (very hard) flywheels need to be ground with softer stones. Our best all-around stone for Billet Steel is the **FGW-50-2**. It's our most friable and free-cutting, requiring minimal dressing.

CAST IRON (Passenger cars, light trucks)

Size	Description	Jobber	Order No.
6"-4½" x 2½" x 1¼"	Harder than FGW-57, lasts longer, black	\$42.49	FGW-67
6"-4½" x 2½" x 1¼"	Best all-around for cast iron, black	42.99	FGW-57
6" x 2½" x 1¼"	Straight-sided FGW-57, black	47.79	FGW-57S
6"-4½" x 2½" x 1¼"	Softer than FGW-47, grinds faster, black	56.29	FGW-54
6"-4½" x 2½" x 1¼"	Softer than FGW-57, grinds faster, black	38.49	FGW-47
6"-4¾" x 2½" x 1¼"	Silicon-carbide, ideal for top fuel, black	42.99	FGW-37
4"-3" x 2" x 1¼"	Small diameter FGW-57, black	44.99	FGW-61
4"-3" x 2" x 1¼"	Small diameter FGW-37, black NEW!	29.99	FGW-37A
3" x 2" x 1¼"	Green Silicon-Carbide	26.99	FGW-93

CAST STEEL (Industrial, agricultural, OTR trucks)

Size	Description	Jobber	Order No.
6"-4½" x 2" x 1¼"	Harder than FGW-65 lasts longer, lt. gray	\$56.29	FGW-53
6"-4½" x 2½" x 1¼"	Best all-around for Cast Steel, speckled	82.49	FGW-65
6"-4½" x 2½" x 1¼"	Slightly softer than FGW-65, black	40.79	FGW-49S
4"-3" x 2" x 1¼"	Small diameter FGW-65, speckled	41.49	FGW-69
6"-4½" x 2½" x 1¼"	Softer than FGW-65, grinds faster, black	67.29	FGW-49

BILLET STEEL (Import vehicles, high-performance)

Size	Description	Jobber	Order No.
6"-4½" x 2½" x 1¼"	Harder, ruby stone, lasts longer	\$72.49	FGW-64
6"-4½" x 2½" x 1¼"	Harder, pink stone, lasts longer	67.29	FGW-62-1
6"-4½" x 2½" x 1¼"	Harder than FGW-50-2, white	54.99	FGW-50
6"-4½" x 2½" x 1¼"	Best all-around for Billet Steel	66.29	FGW-50-2
4"-3½" x 1½" x 1¼"	Harder, pink stone, lasts longer	39.49	FGW-63-1
4"-3" x 2" x 1¼"	Taller than FGW-56, more abrasive, white	44.99	FGW-306
4"-3½" x 1½" x 1¼"	Small diameter FGW-50, white	29.29	FGW-56
3"-2¼" x 1¼" x ¾"	Small diameter, light gray	26.99	FGW-59
3" x 2" x 1¼"	Sugar white stone	23.99	FGW-92

NOTE: Due to manufacturing process, colors may vary.

All abrasives are guaranteed for 1 year from original purchase date.

Mounting Adaptor For Small Diameter Stones

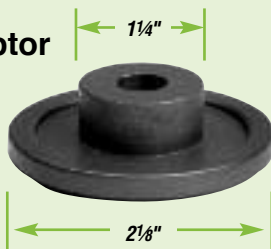

- Many flywheel grinders have lower mounting flanges that won't fit inside 3" and 4" diameter flared-cup stones
- Use this adaptor to avoid damage when mounting small stones
- Fits most small diameter stones
- Order No. **FG-FLANGE** Jobber \$11.99

Flywheel Grinding Stones for Small Arbors and Special Machines

Use	Shape	Diameter	Height	Jobber	Order No.
Winona VanNorman 444 Rotary Grinder - 7/8" Arbor					
Cast Flywheels	Flared	5"-4"	3"	\$119.99	GCV-544
Steel Flywheels	Flared	5"-4"	3"	109.99	GCV-545
Winona VanNorman 570 Rotary Broach - 15/16" Arbor					
Cast Flywheels	Flared	5"-3¾"	1¾"	\$69.79	GCV-305
Steel Flywheels	Flared	5"-3¾"	1¾"	79.99	GCV-306

All abrasives are guaranteed for 1 year from original purchase date

10% off jobber!

Order 5 or more flywheel grinding stones (any combination)



CYLINDER HEAD
REBUILDING

CLEANING,
ASSEMBLY & SAFETY

SHORT BLOCK
REBUILDING

CRANKSHAFT/
FLYWHEEL GRINDING

BRAKE & ALIGNMENT
TOOLS

MEASURING
TOOLS

OFFROAD BIKE, ATV
HARD PARTS

V-TWIN
HARD PARTS

Full Service
... FAST!



"Our goal is to serve you faster and better than anyone else in the industry. We ship the same day we receive your order so you don't have to wait any longer than necessary. And, remember, if you need your order in a hurry, Goodson can ship it overnight, 2-day or any other way. Just tell us when you need it and we'll get it there." – Jon, Customer Service, 17 years of service

shown at approximately full size

CYLINDER HEAD
REBUILDING

CLEANING,
ASSEMBLY & SAFETY

SHORT BLOCK
REBUILDING

CRANKSHAFT/
FLYWHEEL GRINDING

BRAKE & ALIGNMENT
TOOLS

MEASURING
TOOLS

OFFROAD BIKE, ATV
HARD PARTS

V-TWIN
HARD PARTS

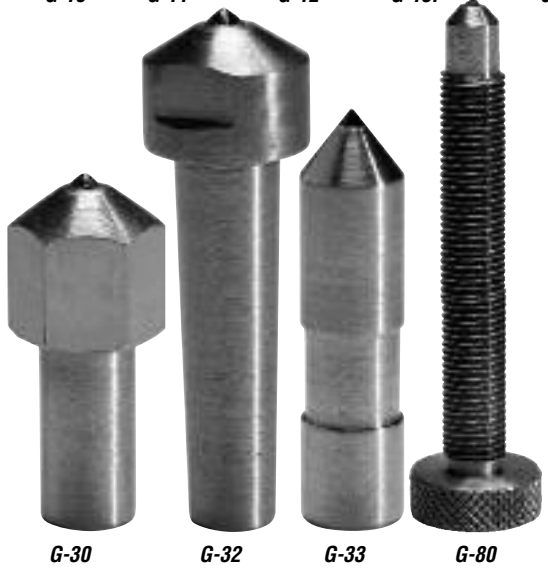
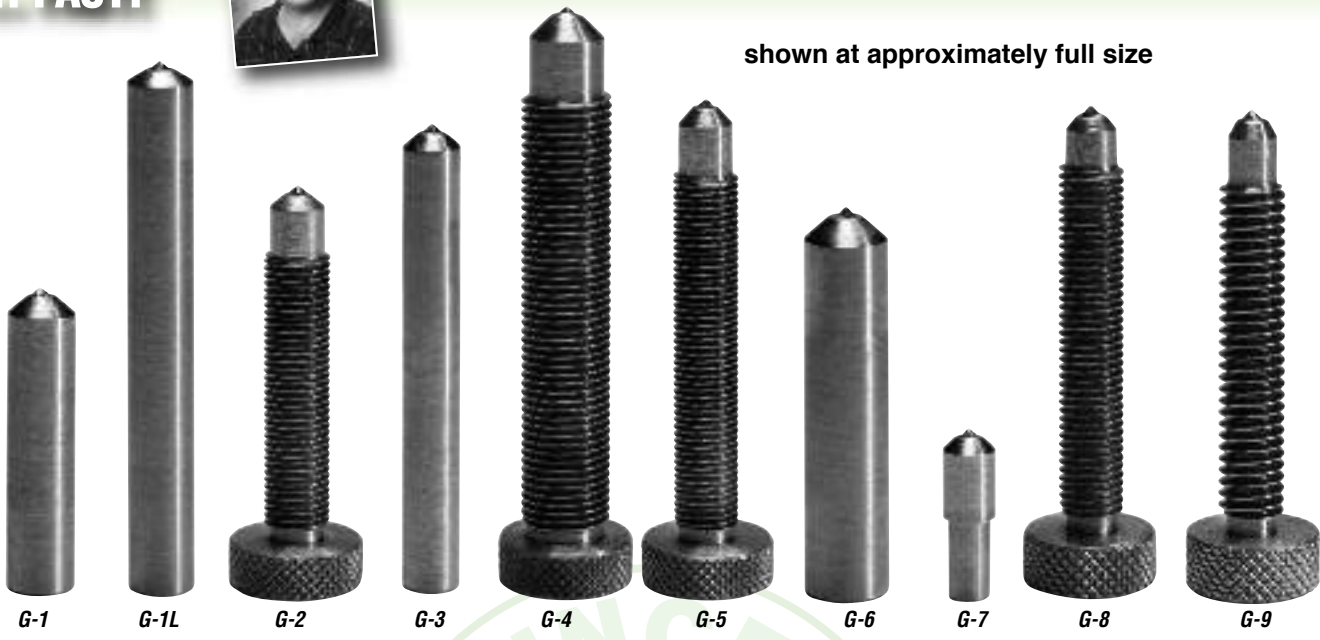

Diamond Resetting Service:

Send in your worn diamonds for fast resetting. Prices quoted upon request. Reset when wear facets exceed $\frac{1}{16}$ " on a $\frac{1}{2}$ to $\frac{3}{4}$ carat diamond and $\frac{1}{8}$ " on a 1 carat or larger. **Grinding wheel must never touch matrix or holder.**

Diamond: Selected for very high point definition. A sharper diamond cuts faster and gives a superior finish.

Matrix: Matrix material is bronze or copper-based for a tight hold on the diamond & high heat transfer.

Holder: Cold rolled steel. Threaded types have precision threads over a long distance to screw easily into tool holders and support cutting point firmly to prevent vibration.

Diamonds are stamped for easy identification and re-ordering

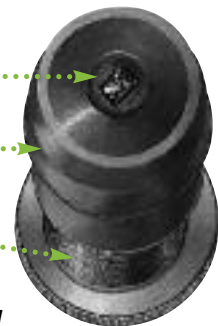

Diamond Dresser Tools

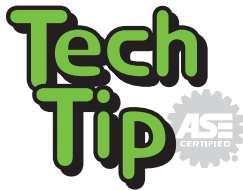

- 1. Set tool at a proper angle.**
Position at 10° to 15° from surface. Smaller angles blunt the diamond. Larger angles may cause the wheel to remove matrix material.
- 2. Prevent vibration in the holder.**
Any looseness in the tool holder will allow vibration of the tool resulting in poor finish on the wheel.
- 3. Turn coolant on before dressing.**
Wheels used wet should be dressed wet. To keep diamond cool, turn coolant on before starting to dress. (If wheel is dressed dry, air-cool diamond between cuts but don't quench with water.)
- 4. Start at highest point.**
Wheels often wear unevenly & may have high & low spots. Set tool to dress high spots first, feed in about .001" per pass until done. This prevents overheating & damage.
- 5. Use steady travel.**
Uneven travel causes an uneven finish. The best rate is found by experiment, but whatever the rate of travel, it must be even.
- 6. Turn the tool in the holder.**
Turn the tool often to expose new diamond surface to the wheel.
- 7. Don't bump or drop diamond.**
They are hard but brittle, and can be harmed if dropped or bumped.

Diamond Dressers for most shop machines - in stock and ready-to-ship

A diamond tool is only as good as the diamond itself. **GOODSON** diamonds are furnished by the most respected supplier in the U.S. Each is subjected to a microscopic examination by experts and must meet strict standards to be accepted. This rigorous inspection and careful control during manufacturing assures consistent high quality. Our diamond tools deliver the highest levels of performance and longevity.

In addition to our standard diamond tools, **GOODSON** stocks a wide selection of Premium-Quality diamonds. These diamonds last longer and improve wheel performance. They stay sharp longer and have more points so they can be reset more times. Because of this quality, they will dress harder wheels and wheels will need to be dressed less frequently. If you don't see the diamond you need in a premium quality, call **800-533-8010** for a special order.

	Machine	Description	Carat	Standard	Premium
Valve Refacers	B&D, Skil, Sioux, Thor, VanDorn, WVN	3/8"x1 1/8"	1/6	\$33.79 G-1	\$62.99 G-1P
	Kwik-Way, Tobin Arp (S&D)	5/16"x2 1/2"	1/6	34.79 G-3	
	Kwik-Way, Valve Master (1714)	1/2"x3 1/4" 20NF	1/6	35.79 G-4	
	Sioux (1713, 1715), IDL, WVN (CG50, CG80)	3/8"x2 3/4" 24NF	1/6	34.79 G-5	59.99 G-5P
	IDL, WVN (CG-50, CG-80)	3/8"x3 1/4" 24NF	1/6	39.99 G-80	69.99 G-80P
	US	7/16"x2"	1/6	34.79 G-6	
	Hall 80, K-W, KO Lee, WVN, KR Wilson	1/4"x1"	1/6	40.99 G-7	
	Skil (Talent)	5/16"x2 1/4" 18NC	1/6	38.99 G-9	
	Van Norman Model 500	3/8"x1 1/8"	1/2	68.29 G-12	
	Kwik-Way	7/16"x2 3/4" 20NF	1/6	34.79 G-17	60.99 G-17P
Valve Seat Grinders	B&D, S&D, Van Dorn	3/8"x2 1/4" 24NF	1/6	36.79 G-2	
	Kwik-Way	1/2"x3 1/4" 20NF	1/6	35.79 G-4	
	Sioux (1715), K-W (NSG), Thor	3/8"x2 3/4" 24NF	1/6	34.79 G-5	59.99 G-5P
	Kwik-Way	1/4"x1"	1/6	40.99 G-7	
	Hall HD (13-1938P), Skil, Snap-On, B&D	5/16"x2 1/4" 24NF	1/6	41.99 G-8	59.99 G-8P
	KO Lee, Skil	5/16"x2 1/4" 18NC	1/6	38.99 G-9	
	Winona Van Norman	1/4"x2"	1/6	35.79 G-10	
	Sioux Heavy Duty (1715B, 1719)	3/8" hex RH	1/6	59.99 G-11	
	Goodson Universal Wheel Dresser	8mm x 1.25mm	1/6		61.99 G-13P
	Sioux Heavy Duty (1715A)	3/8"x2 3/4" 24NF	1/2	59.99 G-15	
	Kwik-Way Heavy Duty	1/2"x3" 20NF	1/6	34.79 G-18	62.99 G-18P
Clutch Grinders	Lempco AC, NAC, VAC & Do-ALL	7/16"x2"	1/6	34.79 G-6	
	Van Norman 444	3/8"x1 1/8"	1/2	68.29 G-12	
Piston Grinders	Van Norman 75, 76 & Relio	3/8"x1 1/8"	1/6	33.79 G-1	62.99 G-1P
	Storm-Vulcan D-3	7/16"x2"	1/6	34.79 G-6	
	Van Norman 101	3/8"x1 1/8"	1/2	68.29 G-12	
Drum Lathes	Van Norman (all except 302, 302H)	3/8"x1 1/8"	1/6	33.79 G-1	62.99 G-1P
	Barret, V.N. 302, 302H	3/8"x3"	1/6	32.79 G-1L	
	Lempco	7/16"x2"	1/6	34.79 G-6	
	Ammco 5000	1/2"x1 1/2"	1/6	31.49 G-19	
Rod Grinders	Sunnen Rod & Cap Grinder (CRG-500)	3/8"x1 1/8"	1/6	33.79 G-1	62.99 G-1P
	Storm-Vulcan No. 65 Rod Grinder	1/2"x3 1/4" 20NF	1/6	35.79 G-4	
Crank and Cam Grinders	Storm-Vulcan 14, 15, 15A, 15C, 75, 75A	1/2"x3"	3/4	124.99 G-25	
		1/2"x3"	1	179.99 G-25A	279.99 G-25AP
	Scledum	10mmx1 1/8"	3/4	125.99 G-27	
		10mmx1 1/8"	1		283.49 G-27AP
		10mmx1 1/8"	1 1/2	214.99 G-27B	409.49 G-27BP
	Winona Van Norman/Zanrosso,	7/16"x1 1/4", 5/8" head	3/4	125.99 G-30	
	Lempco, Landis	7/16"x1 1/4", 5/8" head	1	169.99 G-30A	283.49 G-30AP
		7/16"x1 1/4", 5/8" head	2	304.49 G-30C	
	Berco	tapered, step type	1	179.99 G-32A	279.49 G-32AP
	Berco	tapered, step type	1 1/2	279.99 G-32B	399.99 G-32BP
	Storm-Vulcan, WVN CG210, 250, 280	1/2"x2" 70°rad. dress	3/4	199.49 G-33	
Flywheel Grinder	Kwik-Way 796	7/16"x2"	1/6	34.79 G-6	



Left Hand Drill Bits

• Use to remove material from the center of a broken fastener • Often, as material is removed and pressure is relieved, the left hand rotation unthreads the fastener for easy removal

Size	Jobber	Order No.
.125" x 2.75"	\$ 6.99	DB-125LH
.187" x 3.50"	8.99	DB-187LH
.250" x 4.00"	10.99	DB-250LH
.312" x 4.50"	17.99	DB-312LH
.375" x 5.00"	23.99	DB-375LH

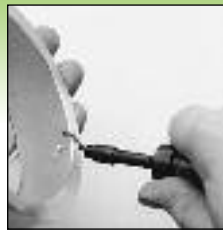

Deburring Tool

• Swivel tool chamfers sharp, machined edges, bolt holes, and much more
• DT-6 includes cutters for aluminum and cast iron

Description	Jobber	Order No.
Deburring Tool	\$18.79	DT-6
Replacement Cutters		
Steel/Aluminum	\$5.49	DT-10
Cast Iron/Brass	5.49	DT-20



14mm Spark Plug Thread Chaser

• Ideal for spark plug hole cleaning
• Re-forms the original material by burnishing, not cutting, and won't create new chips to clean out
• Order No. **SPB-14**
Jobber \$72.29



Burr Buster

• Use on air float tables, seat & guide machines, beds of crankshaft grinders and tables on flywheel grinders • Deburrs gasket surfaces on heads, blocks, manifolds, etc.
• 120 grit premium grade abrasive • 1 1/2" x 2 3/8" x 9"
• Order No. **BB-9**
Jobber \$23.79

TR-216-1 TR-216-3 BJR-2

Premium Tapered Reamers For Tie Rods and Ball Joints

• Use by hand or with a powered driver to deburr or enlarge tapered holes for tie-rod ends or ball joints • Use in 1/2" chuck at approximately 40 RPM



OAL	Flute	Small End	Big End	Taper	Jobber	Order No.
5 3/4"	3 3/4" long	1/8" dia.	1/2" dia.	-----	\$ 35.99	TR-216-1
6 1/2"	4 1/2" long	7/16" dia.	1" dia.	1 1/2" per ft.	129.99	TR-216-2
6 1/2"	4 1/2" long	1 5/16" dia.	1 1/2" dia.	1 1/2" per ft.	149.99	TR-216-3
5"	3" long	1/2" dia.	1" dia.	2" per ft.	167.99	BJR-2

1/2" Composite Pneumatic Wrench

Specifications	
Clutch Mechanism	Twin Hammer
Max. Torque	1000 ft. lbs.
Sound Level	84 dba
Free Speed	9500 RPM
Air Pressure	90 PSI
Air Inlet	1/4" NPT
Air Consumption	4 cfm
Net Weight	4.5 lbs.
Order No.	IW-1000TH
Jobber	\$229.99



Heavy Duty 3/8" Air Ratchet

Specifications	
Max. Torque	90 ft. lbs.
Sound Level	82 dba
Free Speed	180 RPM
Air Pressure	90 PSI
Air Inlet	1/4" NPT
Air Consumption	3.5 cfm
Order No.	AR-38
Jobber	\$149.99



Mini Air Ratchets

Specifications	
Max. Torque	45 ft. lbs.
Sound Level	82 dba
Free Speed	320 RPM
Air Pressure	90 PSI
Air Inlet	1/4" NPT
Air Consumption	3.5 cfm
1/4" Order No.	MR-14
3/8" Order No.	MR-38
Jobber	\$129.99

Bench Grinder Wheels

• 40 and 60 grit for general grinding
• 100 grit for sharpening carbide tools
• Bushings included to reduce arbor hole from 3/4" to 1/2"

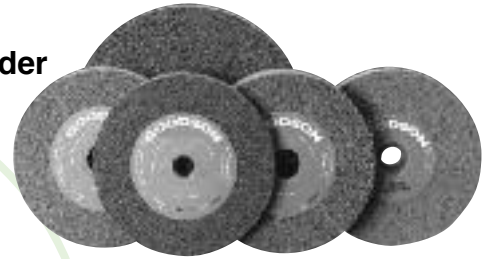

Size	Grit	Jobber	Order No.
General Purpose Wheels: For steel and cast iron			
6" x 1 1/2"	60	\$24.79	GG-646
6" x 3/4"	40	25.79	GG-664
6" x 3/4"	60	25.79	GG-666
6" x 1"	60	26.79	GG-686
7" x 1"	40	29.99	GG-784
8" x 1"	40	31.99	GG-884
8" x 1"	60	32.99	GG-886
Green Grit Wheels: For sharpening carbide tools			
6" x 1 1/2"	100	\$27.99	GGC-641
6" x 3/4"	100	30.99	GGC-661
6" x 1"	100	37.29	GGC-681
3M™ Scotch Brite™ Wheel: For cleaning/polishing valve stems			
6" x 1 1/2" x 1"		\$49.99	SCW-64M

GS-00



GS-0



Grinding Wheel Star Dressers

Hand dresser for wheels up to 10" dia.	\$18.99	GS-0
Hand dresser for wheels 10" to 16" dia.	23.99	GS-1

Replacement Cutter Sets

4 blades, 2 spacers, 1/4" ID for GS-0 dresser	\$6.99	GS-00
4 blades, 2 spacers, 1/2" ID for GS-1 dresser	7.99	GS-11

Deburring Wheels for Bench Grinders

• Medium-hard wheels are better suited for heat sensitive materials • Use to clean and polish white metal • Buff and Blend Wheels deliver the same results as a wire brush but are much safer to work with



Description	Size	Qty.	Jobber	Order No.
Medium-Hard Deburring Wheel	6" x 1" x 1"	1	\$69.99	SCW-68M
Buff and Blend Wheels	6" x 1 1/2" x 1"	5	17.99	BBD-65

Replacement Parts

CYLINDER HEAD
REBUILDING

CLEANING,
ASSEMBLY & SAFETY

SHORT BLOCK
REBUILDING

GRANKSHAFT/
FLYWHEEL GRINDING

BRAKE & ALIGNMENT
TOOLS

MEASURING
TOOLS

OFFROAD BIKE, ATV
HARD PARTS

V-TWIN
HARD PARTS



Replacement Belts For Kwik-Way™ Valve Grinders

Application	Machine	Jobber	Order No.
1 Spindle Belt 14.5" L "O" Ring - 1 Pr.	SVS II	\$13.79	000-2303-62
2 Chuck Belt 10" Cog, 50 tooth	SVS II	20.99	001-1899-90
3 Spindle Belt 18" Serpentine	SVS	34.79	001-1905-20
4 Chuck Belt 12" Cog, 60 tooth	SVS or VS	20.99	001-1899-99
5 Spindle Belt 16" V-Belt	VS	20.99	001-1900-67
6 Chuck Belt 19" 120 tooth	VS	27.29	001-1900-75

Replacement Chuck Balls For Kwik-Way™ Valve Grinders

- Measure chuck ball diameter before ordering to ensure correct replacement
- 6 per set

Diameter	Jobber	Order No.
1/2"	\$39.99	010-2101-27
1 7/32"	34.79	010-2101-35

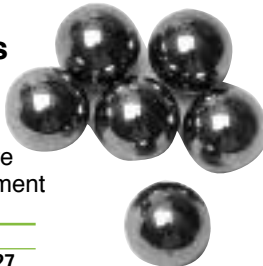

Replacement Switch For Sioux™ Valve Refacer

- For 110V AC models 2001 & 2075 • Early models may need housing modification
- Order No. **SX-18221** Jobber \$56.79



Replacement Gauge For Sioux™ 1630 Vacuum Tester

- Order No. **1630-GAUGE** Jobber \$32.29

Tester no longer manufactured

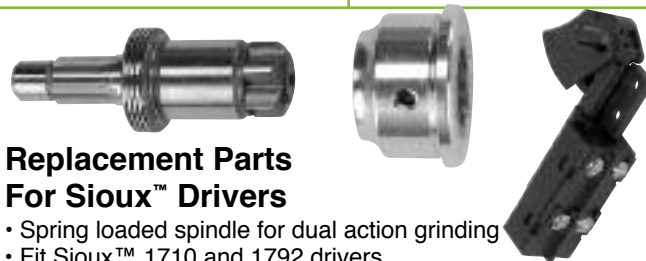

Replacement Parts For Sioux™ Drivers

- Spring loaded spindle for dual action grinding
- Fit Sioux™ 1710 and 1792 drivers

Description	Jobber	Order No.
Replacement Drive Spindle for Sioux™ 1710	\$81.99	SX-22916
Replacement Bearing Cap for Sioux™ 1710	47.29	SX-23694
Replacement Drive Spindle for Sioux™ 1792	81.99	SX-22939
Replacement Bearing Cap for Sioux™ 1792	42.79	SX-33970
Switch for Sioux™ 1710 with plastic handle only	32.49	SX-18204



Quick-Mount Bar Set

- Holds head in place
- Attaches cylinder head to roll over cradle • Fits Goodson Vertical Mill Roll-Over Fixture (pg. 52) as well as many popular seat & guide machines
- Order No. **QMB-95** Jobber \$163.79

Brush Set for Sioux™ 1710 Electric Seat Grinder

- Direct replacement carbon brush for armature
- 3/8" x 1/2" • Includes 1 pair
- Order No. **SX-18004** Jobber \$29.99



Replacement Chuck Balls For Sioux™ Valve Refacers

Fits Models	Jobber	Order No.
680, 2075 (3 pc.)	\$139.99	24185
Chuck Springs for 2075, 2001	95.99	SX-53615

Replacement Belts For Sioux™ 680

Description	Jobber	Order No.
Cog Style 24"x1/2" 120 teeth	\$23.29	SX-14467
Serpentine 29"x1/2" 5 grooves	31.99	SX-14471

Belts For Sioux™ 2075

Description	Jobber	Order No.
Spindle Belt 28 7/8"x1/2" 5 groove	\$28.29	SX-65117
Chuck Belt 23 3/8"x3/8", 115 teeth	17.99	SX-14473

Belts For Sioux™ 645

Description	Jobber	Order No.
Replacement Belt for Grinding Head; Fits Serial #'s up to 34999(2)	\$47.99	SX-14400
Chuck Belt; Fits Serial #'s 34999 & up (also coolant pump belt for #'s 35217 & up).	15.99	SX-14401
Belt for Motor Shaft; Fits Serial #'s up to 34999	20.99	SX-14402
Coolant Pump Belt; Fits Serial #'s 34999-35216	21.99	SX-14403
Belt for Motor Shaft; Fits Serial #'s 35000 & up	31.99	SX-14445
Replacement Belt for Grinding Head; Fits Serial #'s 3500-58700	24.99	SX-14453
Replacement Belt for Grinding Head; Fits Serial #'s 58701 & up	29.99	SX-14461

Replacement Belt For B&D

- Chuck belt for the aluminum housing unit
- Replaced OE V-type belt
- Order No. **BVR-B** Jobber \$25.29

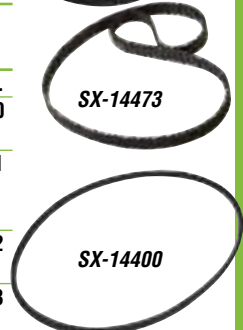

GOODTOOL Brake Service Tools & Supplies are NOW AVAILABLE exclusively through GOODSON!

Automotive Machinist DVDs

Taught by Butch Reilly from Spokane Community College, Easy to understand DVDs are a great addition to any machinist's library.



Title	Run Length	Jobber	Order No.
7 DVD Set (one of each below)	NEW	\$399.99	DVD-SET ▼
Engine Balancing	138 min.	99.99	DVD-EB x
Cylinder Honing	46 min.	99.99	DVD-CH x
Cylinder Boring	52 min.	79.99	DVD-CB x
Crankshaft Grinding (2 DVD set)	113 min.	99.99	DVD-CG2 x
Using a Micrometer	34 min.	65.99	DMV-1 x
Reconditioning Blocks	64 min.	79.99	DRV-1 x

Power Building Videos on DVD

The **Rotating Assemblies** 2-DVD set includes highly detailed, easy to understand information on parts selection and more. The **Engine Building** 3-DVD set includes a stock Small Block Chevy and a mild performance Small Block Ford.



Description	Length	Jobber	Order No.
Rotating Assemblies	4 hours	\$29.99	DVD-RA2
Engine Building	5 hours	36.99	DVD-EB3

How-to-DVDs & Videos

Title	Jobber	Order No.
Street Rod & Performance Engine Building <i>Scott Sehr.</i> Presents the complete parts selection and assembly of a street rod performance engine. 65 minutes.	\$59.99	ERV-65
Basic Engine Building DVD, 2nd edition <i>BoxWrench Media.</i> Step by step engine rebuild. 3 hour run time. Includes 3-D computer models, reference, glossary and more.	\$39.99	BWV-8



How to Build and Modify GM LS-Series Engines

This manual includes information on cylinder head preparation, camshafts, rotating assemblies, assembly and induction/nitrous.
Order No. **MA-148** Jobber \$27.99



In a move to provide you with better pricing and a more complete selection of brake service tooling, GOODTOOL has acquired the product line of GOODTOOL Brake Service Tools & Supplies. These products are the same top quality you've come to expect from GOODSON. Due to the increased buying power, we are able to bring you these items at highly competitive pricing.

GOODTOOL Brake Service Tools & Supplies are now available exclusively from GOODSON. Not only do we have the products but we have tech support on staff to help you with your questions

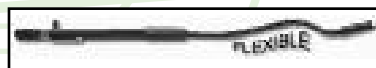

Flexible Penlight

- Unbreakable • Long lasting LED
- Flexible 7" cable and waterproof aircraft quality aluminum casing
- Uses 3 AAAA batteries (included)
- Continuous or on-off operation



Description	Jobber	Order No.
Flexible Light - 17.2" OAL	\$33.99	FL-14
Replacement Batteries (6 pack)	7.99	FL-14B



Ruff-Light

- Built to withstand drops and bumps
- Patented rough-service fluorescent bulb
- Heavy-duty swivel hook • Fully enclosed safety switch

Description	Jobber	Order No.
Ruff-Light w/25' Cord	\$54.99	BL-25
Ruff-Light w/50' Cord	68.99	BL-50
13W Replacement Bulb	11.99	BL-RB

Maxxeon WorkStar™ 220 LED Compact Inspection Light

- 6" inspection light • Weighs just 1 ounce • Black anodized T6 aluminum body • Threaded joints have rubber O-ring seals
- Push-button switch is rated at 100,000 cycles and is sealed to keep out dirt and grit • Runs on 3-AAAA alkaline batteries (included) up to 4 hours
- Order No. **DFL-220** Jobber \$29.99



New!

Tips Are Shown Actual Size

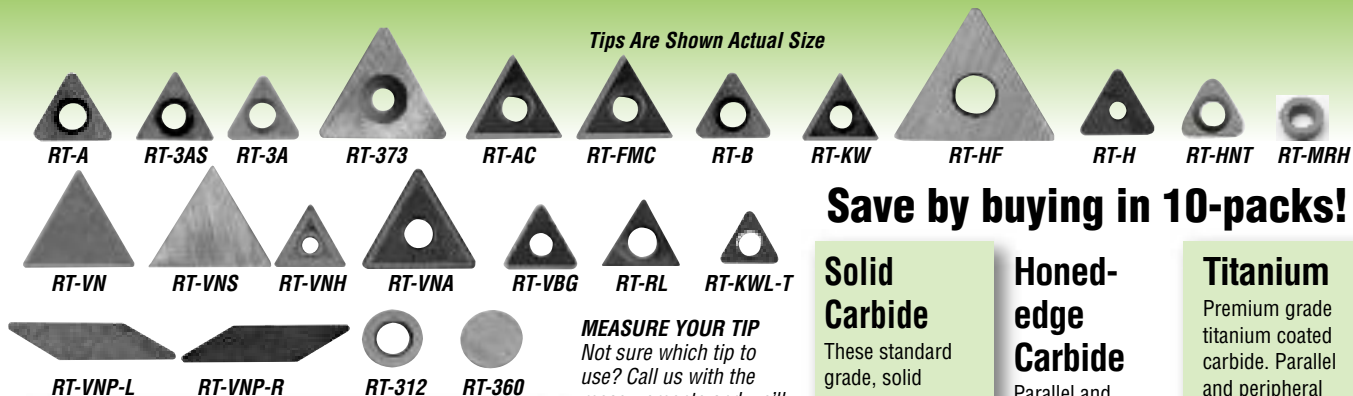

Save by buying in 10-packs!

Solid Carbide

These standard grade, solid carbide cutting tips are parallel ground for resurfacing cast iron drums and rotors.

Honed-edge Carbide

Parallel and peripheral ground. Honed edges deliver a better finish on cast iron and composite rotors.

Titanium

Premium grade titanium coated carbide. Parallel and peripheral ground for ultimate performance on cast iron & composite rotors.

The more you buy, the more you save!

Order 3 or more 10-packs, save 10% off jobber;



MEASURE YOUR TIP
Not sure which tip to use? Call us with the measurements and we'll get you the right tip.

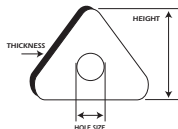

Machine	Model(s)	OE No.	Edges	Rake	Screw	Jobber	Order No.	Jobber	Order No.	Jobber	Order No.
Ammco	700, 710, 1000, 2002, 3000, 4000, 4100, 7000, 7500, 7700	6914	6	Neg	Yes	\$2.79	RT-A	\$2.99	RT-A-H	\$3.59	RT-A-T
	3850 smaller (1/64") radius	6918	3	Pos	Yes	3.99	RT-3AS	4.59	RT-3AS-H	4.99	RT-3AS-T
	larger (1/32") radius	7681	3	Pos	Yes	3.99	RT-3A	4.59	RT-3A-H	4.99	RT-3A-T
Twin Cutters:	6900,6950 negative rake (std.)	6914	6	Neg	Yes	2.79	RT-A	2.99	RT-A-H	3.59	RT-A-T
	positive rake (standard) 1/64" (finer finish)	6918	3	Pos	Yes	3.99	RT-3AS	4.59	RT-3AS-H	4.99	RT-3AS-T
	positive rake (modified) 1/32" (more durable)	7681	3	Pos	Yes	3.99	RT-3A	4.59	RT-3A-H	4.99	RT-3A-T
	7900	6914	6	Neg	Yes	2.79	RT-A	2.99	RT-A-H	3.59	RT-A-T
Ammco HD	5000, 6000, 6002	5677	3	Pos	No	7.99	RT-373				
Accu-Turn	All combination disc/drum lathes	433796	3	Pos	Yes	4.59	RT-AC	4.79	RT-AC-H	4.99	RT-AC-T
	On-The-Car Lathes	878051	6	Neg	Yes	2.79	RT-A	2.99	RT-A-H	3.59	RT-A-T
All-Tool	747	3331	6	Neg	Yes	2.79	RT-A	2.99	RT-A-H	3.59	RT-A-T
Bean	B-401, B-410, B-501, B-601	90487	3	Pos	Yes	3.49	RT-FMC	3.69	RT-FMC-H	4.99	RT-FMC-T
Bear	1410,1466,1467,1468, 1469, 1478	2264,72265,772834	6	Neg	Yes	2.79	RT-B	3.49	RT-B-H		
	10-1430, 10-1435	W136	6	Neg	No	5.99	RT-HF			6.79	RT-HF-T
FMC	600, 601, 700, 701, RotoTruer	90487	3	Pos	Yes	3.49	RT-FMC	3.69	RT-FMC-H	4.99	RT-FMC-T
	505, On-The-Car Lathe	91212	3	Pos	Yes	3.49	RT-KW	3.99	RT-KW-H	4.59	RT-KW-T
Hoffman	660	3331	6	Neg	Yes	2.79	RT-A	2.99	RT-A-H	3.59	RT-A-T
Horvath	All	1605	6	Neg	No	3.99	RT-H				
Hunter	BL300 On-The-Car Lathe	221580-2	6	Neg	Yes	2.79	RT-A	2.99	RT-A-H	3.59	RT-A-T
	BL-500, BL-501, BL-505	6918	3	Pos	Yes	3.99	RT-3AS	4.59	RT-3AS-H	4.99	RT-3AS-T
	BL-500	221-678-3	3	Pos		4.59	RT-HNT				
	Micro Tips of OCL-400 Lathe	221-626-3	3			7.69	RT-MRH				
Kwik-Way	CBL, NCL, SDL Kwik-Lathe OTC Lathe	109-1092-23	3	Pos	Yes	3.49	RT-KW	3.99	RT-KW-H	4.59	RT-KW-T
	Lightening Lathe	109-1092-45	3	Pos	Yes	3.99	RT-KW	3.99	RT-KWL-H	6.99	RT-KWL-T
Performance	6600,7200,7100, 7600	3331	6	Neg	Yes	2.79	RT-A	2.99	RT-A-H	3.59	RT-A-T
Pro-Cut	On-The-Car Lathe	50-701, 50-742	3	Pos	Yes	3.49	RT-VBG	3.99	RT-VBG-H	4.59	RT-VBG-T
RJ West	915D Disc Lathes	W136	6	Neg	No	5.99	RT-HF			6.79	RT-HF-T
	Perfect 400, 1115HD	W139	3	Pos	Yes	4.59	RT-AC	4.79	RT-AC-H	4.99	RT-AC-T
RTI	BRC35 On-The-Car Lathe	91212	3	Pos	Yes	3.99	RT-3A	4.59	RT-3A-H	4.99	RT-3A-T
Snap-On	YA282, YA277, YA278, YA180 OTC Lathe	109-1092-23	3	Pos	Yes	3.49	RT-KW	3.99	RT-KW-H	4.59	RT-KW-T
Van Norman and Rels	204, 204D, 205, 205DC, 415, 243XV	29687	3	Pos	No	3.49	RT-VN	3.99	RT-VN-H	4.59	RT-VN-T
	Smaller (1/64") radius		3	Pos	No	3.49	RT-VNS	3.99	RT-VNS-H	4.59	RT-VNS-T
	Older Model 204	21933	6	Neg	No	4.99	RT-VNH				
	204, 304, 405	29005	6	Neg	No	3.99	RT-VNA			4.59	RT-VNA-T
	303,304,305,404,405,V22	304-7167	2	Pos	No	4.99	RT-VNP-L			6.99	RT-VNP-LT
	204,205,205DR,300,302,333,243,243XV	302-7167	2	Pos	No	4.99	RT-VNP-R			6.99	RT-VNP-RT
	Rels 2000 rotor	45016, 45021	3	Pos	Yes	5.99	RT-RL				
VBG	On-The-Car Lathe	50-701	3	Pos	Yes	3.49	RT-VBG	3.99	RT-VBG-H	4.59	RT-VBG-T
Round Tips with hole	Fits TAM-312 and TFM-312 Holders	RT-312,RT-312T	360°	Pos	No	4.99	RT-312			6.99	RT-312T
	Fits TAM-360SET, solid	CT10	360°	Pos	No	4.99	RT-360			6.99	RT-360T

NOTE: The table above shows the original-equipment cutting tips for Ammco machines. Most of them use negative-rake tool systems. However, some Ammco machines (especially the 4000 and 7000-series) have been modified in the field by using the TAM-25968 and TAM-25969 positive-rake tool holders (see next page). If your machine is shown above to have 6-edge tips but has 3-edge tips, it has been modified – please order our RT-3A or RT-3AS series tips.

ASE certified master machinists on staff to answer your technical questions

CYLINDER HEAD REBUILDING
CLEANING, ASSEMBLY & SAFETY
SHORT BLOCK REBUILDING
FLYWHEEL GRINDING
CRANKSHAFT/ BRAKE & ALIGNMENT TOOLS
MEASURING TOOLS
OFFROAD BIKE, ATV HARD PARTS
V-TWIN HARD PARTS

Brake Lathe Tip Holders

If you're looking for a holder that isn't listed here, give us a call at **1-800-533-8010** to see if we can get it for you.

Machine	Model	Use	OE No.	Jobber	Order No.
Ammco All-Tool Hoffman Performance	1000, 2002, 3000, 4000, 4100, 7700 747 660 6600, 7200, 7100, 7600	For Drums $\frac{1}{2}$ " x $\frac{3}{8}$ " x $2\frac{1}{4}$ " Use: RT-A series, negative rake tips	9872	\$14.99	TAM-41R
Ammco Performance Hoffman All-Tool	3000, 3850, 4000, 4100, 7000 & 6900, 6950 Twin Cutters 6600, 7200, 7100, 7600 660 747	For Rotors $\frac{3}{8}$ " x $\frac{3}{8}$ " x $1\frac{7}{8}$ " Use: RT-A series, negative rake tips	10701 10702	13.99	TAM-701 (R) TAM-702 (L)
Ammco	3000, 3850, 4000, 4100, 7000 & 6900, 6950 Twin Cutters	For Rotors $\frac{3}{8}$ " x $\frac{3}{8}$ " x $1\frac{7}{8}$ " Use: RT-3A & RT-3AS series, positive rake tips	25968 25969	11.99	TAM-25968 (R) TAM-25969 (L)
Ammco	3850	For Drums $\frac{3}{8}$ " x $\frac{3}{8}$ " x $2\frac{3}{16}$ " Use: RT-3A & RT-3AS series, positive rake tips	5390	14.99	TAM-5390
Ammco	2002, 3000, 4000, 4100, 7700	Small Drum Tool $\frac{3}{4}$ " x $\frac{9}{16}$ " x 5" Use: RT-3A series, positive rake tips		34.99	TAM-5392
Ammco	7692 right angle holder (Replaces Ammco Duplex Tool Bit)	Uses: RT-A series, negative rake tips negative rake tips	7692	27.99	TAM-7692
Ammco	1000, 7900 Twin Cutter Cuts from the underside – opposite of other holders	For Flywheels $\frac{3}{8}$ " x $\frac{3}{8}$ " x $1\frac{7}{8}$ " For Drums/Rotors $1\frac{1}{2}$ " x $2\frac{1}{2}$ " Use: RT-A series, negative rake tips (Left Hand Holder Shown)	25762	44.99	TAM-25762 (LH) TAM-25761 (RH)
Ammco HD	5000, 6000, 6002	For Drums $\frac{5}{8}$ " x $\frac{5}{8}$ " x 4" Use: RT-373, positive rake tips	9695	44.99	TAM-9695
Ammco HD	5000, 6000, 6002	For Rotors $\frac{5}{8}$ " x $\frac{5}{8}$ " x $4\frac{1}{2}$ " double-ended (use 2) Use: RT-373, positive rake tips	5878	54.99	TAM-5878
Hunter	BL500	Positive rake $\frac{1}{2}$ " x $1\frac{1}{2}$ " x 2"	2221-677-2	19.99	THNT-677 (R) THNT-676 (L)
Accu-Turn FMC Hoffman	fits all combination lathes 600, 601, 700, 701, RotoTruer Perfect 400	Drums & Rotors $\frac{3}{8}$ " x $\frac{3}{8}$ " x $2\frac{3}{4}$ " Use: RT-AC & RT-FMC series, positive rake tips	433763 433764	14.99	TFM-42R (R) TFM-42L (L)
Bear	1410, 1466, 1467, 1468, 1469, 14781	Drums and Rotors $\frac{3}{8}$ " x $\frac{3}{8}$ " x 3" Use: RT-B series, negative rake tips	90495 90494	12.99	TBR-44R (R) TBR-44L (L)
Kwik-Way Snap-On	CBL, NCL, SDL Y282, Y277, Y278 & 180	$\frac{3}{8}$ " x $\frac{3}{8}$ " x $2\frac{1}{2}$ " Use: RT-KW series, positive rake tips	109-1091-00 109-1091-02	12.99	TKW-84R (R) TKW-85L (L)
Kwik-Way Snap-On	CBL, NCL, SDL Y282, Y277, Y278 & 180	$\frac{3}{8}$ " x $\frac{3}{8}$ " x $1\frac{3}{4}$ " Use RT-KW series, positive rake	108-1009-07 108-1010-08	11.99	TKW-86R (RH) TKW-87L (LH)
Accu-Turn, FMC Ammco, KW	For Curved Rotors with a flange	For Rotors $\frac{3}{8}$ " x $\frac{3}{8}$ " x 3" Use: RT-FMC series, positive rake tips	434057 434056	19.99	TFO-42R (R) TFO-42L (L)
Ammco Hoffman Performance, All-Tool	Direction: Left Direction: Right	$\frac{3}{8}$ " x $\frac{3}{8}$ " x $1\frac{1}{8}$ " $\frac{3}{8}$ " x $\frac{3}{8}$ " x $1\frac{1}{8}$ " Use: RT-312 series tips		24.99	TAM-312L TAM-312R
Ammco Hoffman Performance, All-Tool	Direction: Left Direction: Right	$\frac{3}{8}$ " x $\frac{3}{8}$ " x $1\frac{1}{8}$ " $\frac{3}{8}$ " x $\frac{3}{8}$ " x $1\frac{1}{8}$ " Use: RT-64A		24.99	DTAM-312L DTAM-312R
Accu-turn FMC, Bear, Hoffman, Kwik-Way, Snap-On, etc.	Direction: Left Direction: Right	$\frac{3}{8}$ " x $\frac{3}{8}$ " x $2\frac{3}{4}$ " $\frac{3}{8}$ " x $\frac{3}{8}$ " x $2\frac{3}{4}$ " Use: RT-312 series tips		19.99	TFM-312L TFM-312R
Accu-turn FMC, Bear, Hoffman, Kwik-Way, Snap-On, etc.	Direction: Left Direction: Right	$\frac{3}{8}$ " x $\frac{3}{8}$ " x $2\frac{3}{4}$ " $\frac{3}{8}$ " x $\frac{3}{8}$ " x $2\frac{3}{4}$ " Use: RT-64AC		24.99	DTFM-312L DTFM-312R
Hunter	Set of holders & tips (1 of each)	Use RT-MRH tips		49.99	RT-MRH-SET

*DTAM-SET & DTFM-SET include 10 Tips (6-RT-312T & 4 RT-A or RT-AC depending on set ordered) see p. 115

 CYLINDER HEAD
REBUILDING

 CLEANING,
ASSEMBLY & SAFETY

 SHORT BLOCK
REBUILDING

 CRANKSHAFT/
FLYWHEEL GRINDING

 BRAKE & ALIGNMENT
TOOLS

 MEASURING
TOOLS

 OFFROAD BIKE, ATV
HARD PARTS

 V-TWIN
HARD PARTS

Brake Lathe Tools & Silencers

New!

Neoprene Brake Lathe Silencer

- Longer lasting than rubber
- Neoprene material resists deterioration associated with standard rubber belts
- 7 weights
- Measures: 34" L x 5/8" W x 3/16" Thick
- Order No. **GT-6030N** Jobber \$19.99

GOODTOOL
now exclusively from Goodson

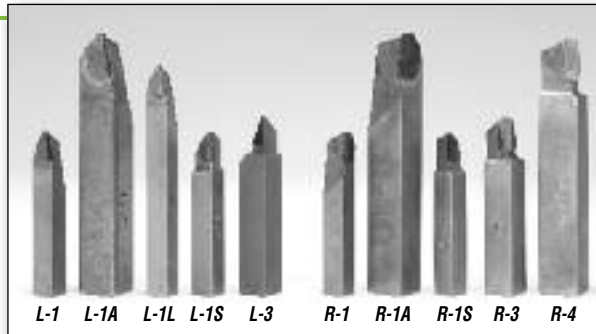

Brazed Carbide Brake Lathe Tools

- Fit most popular brake drum lathes

Left Hand Cutting Tools

Size	Application	Jobber	Order No.
3/8" sq. x 2 1/2"	Replaces Bean 43-46L; Bear 23211; Star CB-8; VN 302-7272 for 303, 304, 304H	\$11.99	L-1
5/8" sq. x 4"	Replaces Ammco 5725, for 5000; Star CB-30; VN "Big Brute" for 310-404 Hardspots	14.99	L-1A
3/8" sq. x 3 1/2"	Extra long L-1 for small dia. drums	11.99	L-1L
3/8" sq. x 2 1/2"	Master carbide-tipped with 7" rake angle	14.99	L-1S
1/2" sq. x 2 3/4"	Replaces Ammco 4726 heavy-duty tool Ammco 4726 for 5000 & 6000 dual facing tool & 3000, 4000, 4100 & 7700 lathes	14.99	L-3

Right Hand Cutting Tools

Size	Application	Jobber	Order No.
3/8" sq. x 2 1/2"	Replaces Bean 43-46R; Bear 20718; Star LB-16; VN 302-7171 for 204, 300, 302, 302H, 333, 243XV; and Barrett & Lempc	\$11.99	R-1
5/8" sq. x 4"	Replaces Ammco 5720 for 5000; Lempc SHD, DH, 530 Kwik-Way Heavy Duty	19.99	R-1A
3/8" sq. x 2 1/2"	Master carbide-tipped with 7" rake angle	14.99	R-1S
1/2" sq. x 2 3/4"	Replaces Ammco 4725 for 3000, 4000, 4100, 7100 drum lathes	14.99	R-3
5/8" sq. x 4"	Replaces Bear 24034; Star CB-35	14.99	R-4

Hardspot Cutters

Left Hand

Size	Use	Order No.
3/8" x 1 1/2" x 2 3/8"	Drums	L-5
	Discs	L-6

Right Hand

Size	Use	Order No.
3/8" x 3/8" x 2 3/8"	Drums	R-5
	Discs	R-6

Jobber \$14.99



L-6 L-5 R-5 R-6



Silencers For Vented Rotors

Style	Size	OE No.	Jobber	Order No.
Rubber Strap	34"L x 5/8"W x 3/16" thick	6920	\$16.99	CE-8
	36"L x 1 1/4"W x 3/16" thick	6930	29.99	CE-6930
Spring	Fits 6" to 9" rotors		27.99	CE-13
Rubber Tube	9" Diameter, 6 weights		19.99	CE-5
	8" Diameter, 4 weights		19.99	CE-5S

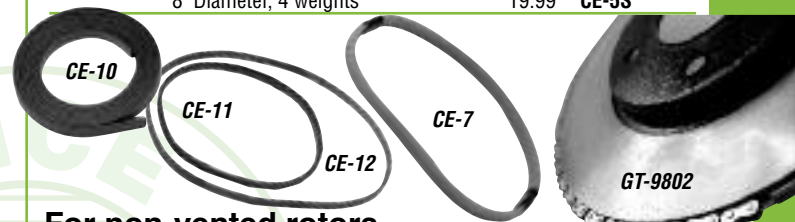

For non-vented rotors

Style	Size	Jobber	Order No.
Magnetic Strap	48" long	\$ 9.99	CE-10
Rubber Band	6 1/2" dia. x 5/16" W x 3/16" thick	4.99	CE-11
	9 1/4" dia. x 5/16" W x 3/16" thick	4.99	CE-12
Rubber Tube	Fits 6" to 9" rotors	7.99	CE-7
Chain Band	Nickel plated with 4-springs	47.99	GT-9802



For vented and non-vented rotors

Style	Application	Jobber	Order No.
Clamp-On	For Bench model lathes	\$27.99	CE-6
	For On-The-Car lathes	26.29	CE-26
Friction	Most Ammco lathes	149.99	7075
	Replacement Pucks for 7075	11.99	CE-9
	Replacement Mounting Bracket	17.99	GT-10283
	Replacement Wrench	5.99	GT-11497



For Drums

Style	Application	Jobber	Order No.	
Rubber Strap	Automobiles	5'L x 2 7/8"W x 1/8" thick	\$16.99	CE-1
		5'L x 1 1/8"W x 1/4" thick	16.99	CE-3
	Trucks	6'6"L x 2 7/8"W x 1/8" thick	18.99	CE-2
		6'6"L x 1 1/8"W x 1/4" thick	19.49	CE-4
Ammco Style		6'L x 1 3/4"W x 3/16" thick	21.99	CE-5280

CYLINDER HEAD
REBUILDING

CLEANING,
ASSEMBLY & SAFETY

CRANKSHAFT/
LYWHEEL GRINDING

BRAKE & ALIGNMENT
TOOLS

MEASURING
TOOLS

OFFROAD BIKE, ATV
HARD PARTS

V-TWIN
HARD PARTS



GT-433701 GT-8542 GT-3101 1101 4101 GT-90043 GT-5389 GT-974222 GT-20442

Top-quality arbors meet or exceed OE specs

- Factory checked for runout of less than .001"
- Heat treated, stress relieved tool steel
- For drums and rotors up to 125 lbs.
- Precision ground between centers using only one set-up for the greatest accuracy

GOODTOOL
now exclusively from Goodson

1" Arbors

Machine	Model(s)	Thread	Jobber	Order No.
Accu-Turn	7700, 8910, 8911, 8920, 8922, 8944, 8989, 8990, 8991, 8993, 8985 and 8997	1" x 8 LH	\$149.99	GT-433701
Hunter All Tool	Early Models, BL 500	1" x 8 LH	159.99	GT-8542
Performance	747			
Ammco	2002, 3000, 4000, 4100, 7000, 7500, 7700	7/8" x 9 LH	149.99	GT-3101
	1000	7/8" x 9 RH	254.99	1101
	3850	7/8" x 9 LH	263.99	4101
FMC/John Bean	600 & 700 Series	1" x 8 LH	129.99	GT-90043
Hoffman	201 Standard, 300, 350, 400, 401, 450 &	1" x 9 LH	179.99	GT-5389
RJ West	1115 HD Lathe			
Hunter	BL 501, BL-505	1" x 8 LH	179.99	GT-974222
VanNorman/Rels		1" x 8 LH	269.99	GT-20442
John Bean/FMC	800 series			

1" Arbor Accessories

Description	Model(s)	Thread	Jobber	Order No.
Arbor Nuts	Fits all Ammco but 1101	7/8" x 9 LH	\$11.99	GT-3102
	Fits Ammco 1101 arbor	7/8" x 9 RH	31.99	25811
	All arbors above but Ammco	1" x 8 LH	12.29	GT-20442N
	Fits Hoffman 5389 only	1" x 9 LH	17.99	GT-5389N
Washer	for VN / Rels Arbor		9.99	GT-20442W
Centering Spring			2.99	GT-3110

1" Spacers	Length	Jobber	Order No.
for ALL Brake Lathes	1/2"	\$4.99	GT-3125
	1"	9.99	GT-5040
	1 1/2"	10.99	GT-5041
	2"	10.99	GT-5042
	Flexible	26.99	GT-9492



Tech Tip

Q: How can I tell if my arbor is bent? It looks okay, but I'd like to check it. What do I do?

A: A fast, but costly way to tell if you have a bent arbor is to check a rotor you've just machined. If it has more run-out than it did before you started, you have a bent arbor. We recommend checking the arbor using a dial indicator on a regular basis. Take three readings – one at the end of the arbor, one in the middle and one close to the lathe. If there's more than .001" difference, it's time to replace the arbor with a new one. Be sure to replace the arbor nut at the same time to prevent premature wear on the arbor threads. Performing this simple test on a regular basis will save you the time and money of re-cutting rotors because the arbor was bent.

For more information, visit our online technical library.

Replacement Work Light

- 30" adjustable arm lets you position the light exactly where you need it • 3/8" round mounting end
- Uses up to 100W standard bulb (not included)
- Easily accessible on/off switch
- Fits most Ammco models
- Order No. **GT-7963**
Jobber \$89.99



1HP Replacement Motor for Ammco Brake Lathes

Ammco Brake Lathes

- Fits 3000, 4000, 4100, 7000, 7500, & 7700 models
- 208/230/115V
- 1725 RPM • 60Hz
- Order No. **GT-2165**
Jobber \$299.99



Right Angle Drive Assembly for Ammco Brake Lathes

- Fits 3000 & 4000 lathes
- Eliminates radial & axial play
- Order No. **GT-9815**
Jobber \$279.99

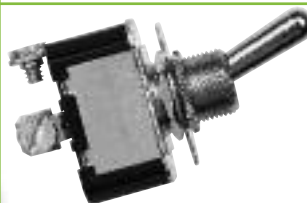

Replacement Switch for Ammco Brake Lathes

- Easy to install
- Fits most models
- Order No. **GT-7893**
Jobber \$9.99

GOODTOOL
now exclusively from Goodson

Ammco Brake Lathe Replacement Parts

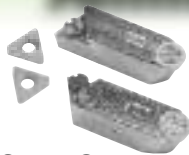

Chip Shield & Twin Cutter for Ammco

- Includes Double Duty Holders and cutting tips
- Fits Ammco 4000, 7000 & 3850

Description	Jobber	Order No.	Incl.
Chip Shield & Bracket	\$ 49.99	GT-9481	
Twin Cutter (Replaces obsolete 6900)	739.99	6950	▼
Double Duty Cutting Tip Holder - Left	24.99	DTAM-312L	1
Double Duty Cutting Tip Holder - Right	24.99	DTAM-312R	1

Double Duty Brake Lathe Tip Holders

- Round holder on one end and triangular holder on the other

Application	Jobber	Order No.	Incl.		
Ammco, All-Tool, Hoffman, Performance	\$79.99	DTAM-SET			
FMC, Accu-Turn, Hoffman, Kwik-Way, VanNorman	79.99	DTFM-SET	▼		
Application	Size	Jobber	Order No.	Incl.	
Ammco, Hoffman, Performance, All-Tool	3/8" x 3/8" x 1 1/16"	Left	\$24.99	DTAM-312L	x
		Right	24.99	DTAM-312R	x
FMC, Accu-Turn	3/8" x 3/8" x 2 3/4"	Left	24.99	DTFM-312L	x
Hoffman 400, Kwik-Way, VanNorman		Right	24.99	DTFM-312R	x
Ammco Tips (6-RT-312T-, 4-RT-A)			59.99	RT-64A	x
Accu-Turn (6-RT-312T, 4-RT-AC)			59.99	RT-64AC	x

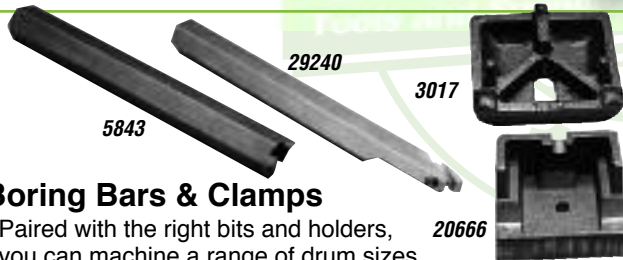

Boring Bars & Clamps

- Paired with the right bits and holders, you can machine a range of drum sizes.

Description	Fits Ammco Model(s)	Jobber	Order No.
1 1/2" hex x 15 1/2"	3000, 4000	\$159.99	5843
1 1/2" hex x 19 1/2"	4100, 4000, 3000	129.99	5844
1 1/2" hex x 16 1/2"	3850	136.99	29240
Upper Clamp		21.99	3017
Lower Clamp		59.99	20666



Tooling Hold Down Pieces

Description	Jobber	Order No.	Incl.
Stud Assembly	\$19.99	GT-25900	▼
6 1/2" Stud	4.99	GT-25913	x
Nut Assembly (must be used with 6 1/2" Stud)	16.99	GT-11227	x
5 1/2" Stud	5.99	GT-3031	
Washers (2)	8.99	GT-3165	

GOODTOOL
now exclusively from Goodson

LSB-78529

Expansion Assemblies for Ammco 4000 & 4100 Lathes

- Expand the capacity of your lathe up to 17 1/16" diameter rotors

Description	Max. Dia.	Application	Jobber	Order No.	Incl.
Lathe Expansion Set			\$249.99	GT-7935	▼
Lead Screw Bushing	15"	SUVs, Pick-ups	24.99	LSB-78529	x
Cross Feed Extension	17 1/16"	1-ton + Trucks	184.99	GT-7936	x
Lower Guide Bar (extends range by 1 1/2")	19 1/4" L		39.99	GT-70346	x

Tool Bit Holders for 6900 & 6950 Twin Cutters

Direction	Jobber	Order No.
Left-Hand	\$69.99	10650
Right-Hand	69.99	10651
Repl. Screw	1.29	GT-9249

Brass Wear Inserts

Size	Order No.
3/16" x 1/8"	GT-3141
1/8" x 1/4" (most popular)	GT-3142
1/4" x 1/8"	GT-9836

Jobber \$1.99



Replacement Seals

Application	Order No.
Feed Screw	3163
Spindle	3164

Jobber \$4.29



Small Replacement Parts

Description	Jobber	Order No.
Locking Knob	\$1.99	6854
Cross Feed Shear Gear with C-Clip	\$4.99	7996



Ammco Rotor & Drum Feed Screws & Nuts

Description	Jobber	Order No.
Rotor Feed Nut (early)	\$23.99	GT-10868
Rotor Feed Nut (late)	23.99	GT-10868X
Drum Feed Nut (all)	43.99	GT-4670
Rotor Feed Screw (4000)	64.99	GT-32111
Rotor Feed Screw (7000)	59.99	GT-10318
Lead Drum Feed Screw (3000, 4000)	109.99	GT-9918

thousands of items in stock for same day shipping

CYLINDER HEAD
REBUILDING

CLEANING,
ASSEMBLY & SAFETY

SHORT BLOCK
REBUILDING

CRANKSHAFT/
FLYWHEEL GRINDING

BRAKE & ALIGNMENT
TOOLS

MEASURING
TOOLS

OFFROAD BIKE, ATV
HARD PARTS

V-TWIN
HARD PARTS

Full Service ... FAST!



"When you call Goodson, you speak to a person first – not a machine. We work hard to make sure that we answer your calls promptly and avoid keeping you on hold whenever possible."
– Wendy, Goodson Sales Administrator - 25 years of service

Screw Feed Boot #3086

Spindle Boot #3085

Cross Feed Boot #3087

GOODTOOL
now exclusively from Goodson



Replacement Boot Packs

- Keep extra boots on hand for routine maintenance or emergency replacement
- Fits Ammco 3000, 4000, 4100, 7000, 7700



Replacement Parts Pack

- Save time - never be caught without one of these essential brake lathe replacement parts again
- Save money - pack price is 10% lower than ordering all parts separately
- Save on shipping - purchasing these parts together costs less in shipping than ordering them individually at different times. You pay shipping and handling one time instead of several • All parts are also sold separately

Description	Jobber	Order No.	Incl.		
Neoprene Boot Pack	\$49.99	GT-BOOT-PK	▼		
Rubber Boot Pack	54.99	RSB-BOOT-PK	▼		
Neoprene Spindle Boot Kit	36.99	SBR-KIT	▼		
Rubber Spindle Boot Kit	39.99	RSB-KIT	▼		
Rubber Spindle Boot	19.99	RSB-3085	x	x	
Neoprene Spindle Boot	15.99	3085		x	x
Screw Feed Dust Boot	8.99	3086			x x
Cross Feed Dust Boot	9.99	3087			x x
Boot Ring	21.99	23682	x	x	x x
C-Clip	1.49	SBR-4435	x	x	x x
Snap Ring	2.99	SBR-3159	x	x	x x

Description	Jobber	Order No.	Incl.	
Replacement Parts Pack	\$45.99	GT-PARTS-PK	▼	
Cross Feed Shear Gear	4.99	7996		2
Replacement Locking Knob	1.99	6854		2
Feed Seal	4.29	3163		1
Spindle Seal	4.29	3164		1
Neoprene Spindle Boot	15.99	3085		1
Screw Feed Dust Boot	8.99	3086		1
Cross Feed Dust Boot	9.99	3087		1

GOODTOOL
now exclusively from Goodson

Drive Pulleys & Belts for Ammco

- Fit Ammco 3000, 4000, 4100, 7000 & 7100
- Serpentine design runs quieter and increases arbor speed by 175RPMs • Virtually eliminates vibration

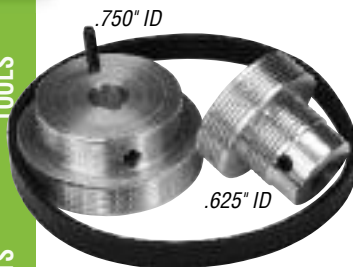

New-Style (Serpentine)

Description	Jobber	Order No.
Pulley Set (Includes 20¼" belt & 2 pulleys)	\$109.99	GT-5001
20¼" Belt	19.99	GT-5002
19" Belt	19.99	GT-5003

Install the drive pulley with the pin toward the right angle drive. The two roll-pins drive against each other. A nylon sleeve prevents metal to metal contact.

Original-Style (V-belt)

Description	Jobber	Order No.
Drive Pulley (Motor)	\$44.99	GT-3024
Driven Pulley (Arbor)	66.99	GT-7784-1
25" (replaces OE 3161)	8.99	GT-3161
24" (replaces OE 10241)	8.99	GT-10241

Brake Shoe Grinding Sleeves

Dia.	Lgth.	Grit	Application	Jobber	Order No.
3"	3"	100	Fits most models	\$ 2.09	AS-1
3"	5¼"	40	Fits most models	4.69	AS-2
3"	6"	40	Fits most models	4.49	AS-3
3"	6¾"	40	Fits most models	4.19	AS-4
3"	7½"	40	Fits most models	6.19	AS-6
2⅞"	4½"	50	Fits Ammco 2007	3.09	AS-7
2⅞"	4½"	24	Fits Ammco	4.19	AS-7C
4"	6"	24	Shepard-Thompson	6.69	AS-8
4"	8¼"	40	Shepard-Thompson	14.99	AS-10
3"	4½"	50	Star	3.09	AS-11

Buy all 3 sizes,
Save 10% off jobber



Brake Drum Swedge Cutting Tool

- Hard-to-find tool cuts wheel stud swedges to remove and replace pressed-in wheel studs • Carbide tipped • Use with a drill press or mill

Stud Size	Jobber	Order No.
7/16" (.4375")	\$89.99	ST-437
1/2" (.5000")	89.99	ST-500
5/8" (.6250")	89.99	ST-562

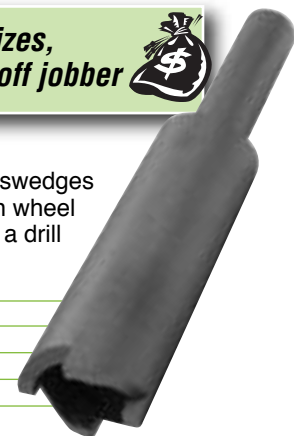

Brake Lathe Replacement Parts

GOODTOOL
now exclusively from Goodson

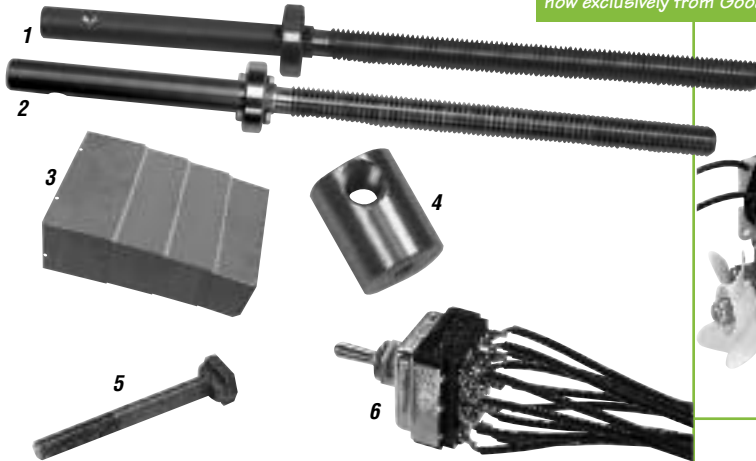

Assorted Replacement Parts
Keep your Accu-Turn Brake Lathe running in tip-top shape

Description	Jobber	Order No.
1 Rotor Feed Screw Assembly (1/2" 20TPI)	\$46.99	GT-433156
2 Drum Feed Screw Assembly (1/2" 13TPI)	45.99	GT-433157
3 Telescoping Way Assembly (fits all except 8989)	189.99	GT-433735
4 Rotor Feed Nut	32.99	GT-433647
5 T-Bolt	13.99	GT-433633
Drum Feed Nut (not shown)	29.99	GT-433646
6 Replacement Switch	69.99	GT-3693

Replacement Feed Motor For Accu-Turn Brake Lathes

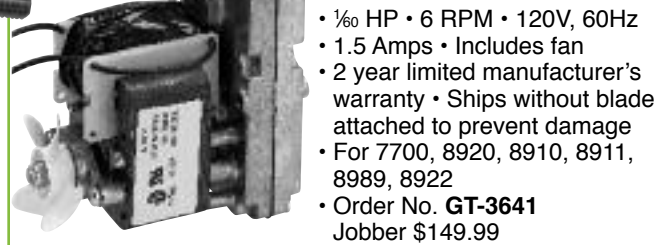

- 1/60 HP • 6 RPM • 120V, 60Hz
- 1.5 Amps • Includes fan
- 2 year limited manufacturer's warranty • Ships without blade attached to prevent damage
- For 7700, 8920, 8910, 8911, 8989, 8922
- Order No. **GT-3641** Jobber \$149.99

Variable Speed Replacement Feed Motor For Accu-Turn 8944 & VN V-22 Brake Lathes



- 90 Volt DC Permanent Magnet Gear Motor
- 1/8 HP • RPM F/L: 21 • Torque F/L: 50 in-lbs.
- Ratio: 16:1 • Mounting: Face • 5/16" diameter shaft
- Continuous duty • Sleeve bearings in motor and gearbox
- 2 year limited manufacturer's warranty
- Order No. **GT-6116** Jobber \$349.99

GOODTOOL
now exclusively from Goodson

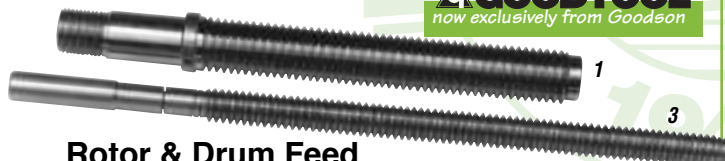

Rotor & Drum Feed Screws & Nuts For FMC & Bean

Description	Jobber	Order No.
1 Rotor Feed Screw	\$39.99	GT-90071
2 Rotor Feed Nut	32.99	GT-90077
3 Drum Feed Screw	28.99	GT-90667
4 Drum Feed Nut	27.99	GT-1016845



Brake Caliper Flex-Hones®

- 180 Grit Silicon-carbide abrasive
- Use a hone one size larger than the bore size for best wall contact
- Compact body

Size	Jobber	Order No.
1 1/2"	\$22.99	BCF-150
1 3/4"	22.99	BCF-175
2 1/8"	24.99	BCF-2125
2 1/2"	27.99	BCF-250
2 3/4"	31.99	BCF-275
3 1/8"	32.99	BCF-3125

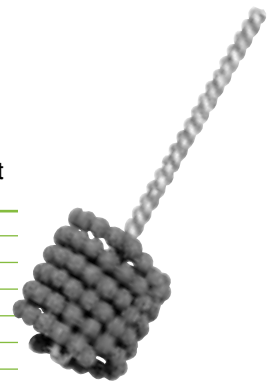

See page 72 for more Flex-Hones®

BRM

Brake Rotor Flex-Hones®

- Provide a non-directional finish
- Use with a 5/8" variable speed drill at 600-1000 RPM • Use dry
- Zirconium abrasive

Type	Grit	Order No.
Fine	240	BRF-25F
Medium	120	BRF-25M
Coarse	60	BRF-25C

Jobber \$49.49

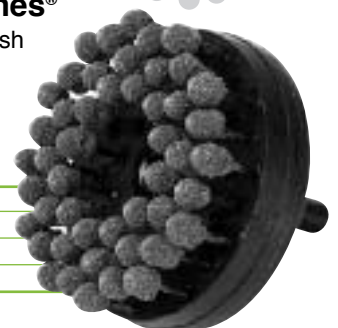

New!



Strip Dip™ Brake Fluid Test Strips

- Simple, visual test to determine brake fluid condition
- Easy to read bright colored results
- Provides a recommendation for service and strip can be given to customer for visual proof of contamination
- NOT a moisture test • Tests dissolved metal contamination in brake fluid • 100 test strips per package
- Order No. **BF-TS** Jobber \$69.99

CYLINDER HEAD REBUILDING
CLEANING, ASSEMBLY & SAFETY
SHORT BLOCK REBUILDING
FLYWHEEL GRINDING
CRANKSHAFT/FLYWHEEL GRINDING
BRAKE & ALIGNMENT TOOLS
MEASURING TOOLS
OFFROAD BIKE, ATV HARD PARTS
V-TWIN HARD PARTS

**Full Service
...FAST!!**



"We pride ourselves on getting orders to our customers quickly. We stock a wide variety of products so that we can get your order to you usually in 2 to 3 days!"

- Jill, Sales Representative, 9 years of service

Replace a wall of adaptors

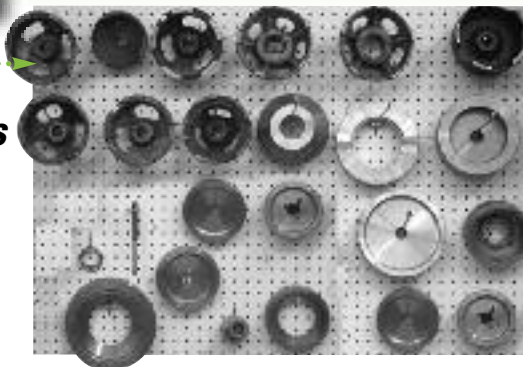

with the Quick Chuck



Automotive Chuck Adaptor Kit (GT-70040)

Quick Chuck Adaptor Replaces a Whole Wall of Adaptors, Centering Cones, Spacers, etc.

- Eliminates mounting problems with the unique self-centering feature
- Fits hubless rotors and drums, composite rotors and drums
- Fits most foreign and domestic rotors, drums and flywheels, including light trucks with a centering hole from 2 1/8" to 5 3/4"
- Fits all popular 1" arbor brake lathes

Truck Chuck Adaptor Kit (GT-74160)



Description	Range	Jobber	Order No.	Incl.
Automotive Chuck Adaptor Kit	2 1/8" to 3 3/4"	\$549.99	GT-70040	▼
Truck Chuck Adaptor Kit	2 1/8" to 5 3/4"	829.99	GT-74160	▼
Replacement Automotive Jaws	2 1/8" to 3 3/4"	134.99	GT-70045	
Large Jaw Set	3 3/4" to 5 3/4"	124.99	GT-70041	x
Quick Chuck Adaptor w/Jaws		484.99	GT-70042	x x
Standard Backing Plate, 5.2"OD		139.99	GT-70043	x x
Chuck Key		59.99	GT-70044	x x
Truck Plate (7 1/4" OD)		124.99	GT-70046	x
Small Automotive Plate (4 1/4" OD)		124.99	GT-70047	
Toyota Plate (6 1/4" OD)		129.99	GT-70054	

Visit www.goodson.com/tech to see how easy it is to install the Quick Chuck

Automotive Adaptors for 1" Arbor Brake Lathes



Description	Jobber	Order No.	Includes
Goodtool Master Tooling Set			
15 Piece Set	\$429.99	GT-4346	▼
Automotive Bell Clamps for 1" Arbors			
OD Size			
3.625"	\$34.99	GT-9489	x
4.500"	35.99	GT-9490	x
5.750"	39.99	GT-3123	x
Single-Tapered Centering Cones for 1" Arbors			
7-Piece Set	\$179.99	GT-3777	▼
Range			
1.250" - 1.750"	24.99	GT-3902	x x
1.187" - 2.250"	35.99	GT-3903	x x
1.703" - 2.750"	26.99	GT-3904	x x
2.328" - 2.986"	29.99	GT-3108	x x
2.650" - 3.224"	32.99	GT-3178	x x
2.890" - 3.500"	31.99	GT-3107	x x
3.421" - 4.031"	32.99	GT-3106	x x
Double-Tapered Centering Cones for 1" Arbors			
2 Piece Set	\$149.99	GT-9233	▼
5 Piece Set	179.99	GT-9232	▼
Range			
1.322" - 1.670"	33.99	GT-9921	x x
1.362" - 1.710"	36.99	GT-9922	x x
1.711" - 2.073"	39.99	GT-9192	x x
2.074" - 2.440"	41.99	GT-9193	x x
2.441" - 2.897"	46.99	GT-9194	x x
2.828" - 3.185"	79.99	GT-9195	x
3.203" - 3.560"	81.99	GT-9196	x

Hubless Rotor Mounting Set

- Pre-hardened, alloy steel

Description	Jobber	Order No.	Incl.
Complete Set	\$549.99	GT-3010	▼
Centering Cones			
1.187" to 2.250"	35.99	GT-3003	x
2.032" to 3.975"	49.99	GT-3004	x
Front Cup with Spring			
5 1/4" dia.	119.99	GT-3002	x
7" dia.	154.99	GT-3006	x
Spacers			
1" long	9.99	GT-5040	x
1 1/2" long	10.99	GT-5041	x
Self-aligning	26.99	GT-9492	x
Backing Plates			
5.25"	74.99	GT-3001	x
7.00"	89.99	GT-3005	x

More sets and individual pieces are listed on the website

GOODTOOL
now exclusively from Goodson

Universal Adaptor Plus Mounting System

- Mount hubless drums, rotors and composite rotors to 1" arbors
- Cones center workpieces with holes 2 5/8" to 6"

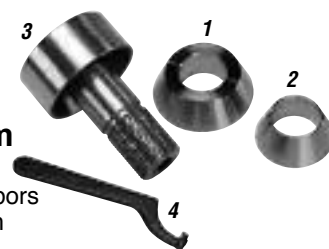

Description	Jobber	Order No.	Incl.
Hubless Locator Assembly	\$159.99	AP-4700	▼
1 Hubless Adaptor Cone (3.125" x 4.25")	102.91	AP-1003B	x
2 Hubless Adaptor Cone (2.125" x 3.25")	61.79	AP-1003A	x
3 Locator for 1" Arbor	99.99	AP-1001	x
4 Spanner Wrench	21.99	HA-800W	x

More sets and individual pieces are listed on the website

CYLINDER HEAD REBUILDING
CLEANING, ASSEMBLY & SAFETY
SHORT BLOCK REBUILDING
CRANKSHAFT/ FLYWHEEL GRINDING
BRAKE & ALIGNMENT TOOLS
MEASURING TOOLS
OFFROAD BIKE, ATV HARD PARTS
V-TWIN HARD PARTS

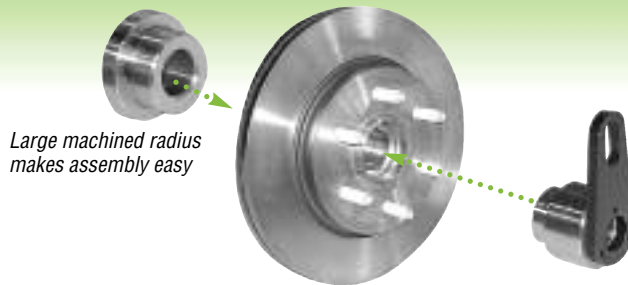

Large machined radius makes assembly easy

Ford F-150 Adaptor

- Machine 2004 & newer Ford F-150 2WD rotors without removing the bearings • Fast, simple setup means less time spent on mounting the rotor on your lathe • Two piece kit includes outboard centering drive adaptor and rear centering adaptor • Approved for late model Ford F-150 two-wheel drive applications with pressed in bearings
- Order No. **FRA-5532** Jobber \$169.99

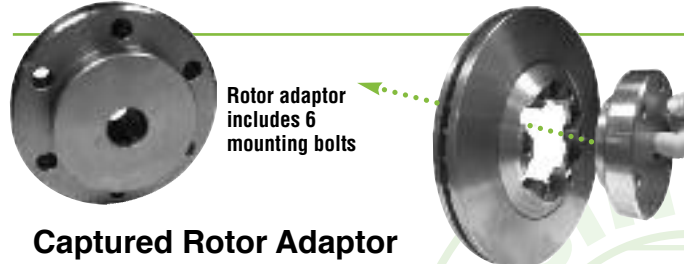

Rotor adaptor includes 6 mounting bolts

Captured Rotor Adaptor for 2004 & later Chevy Colorado & GMC Canyon models

- One-piece, self-centering rotor adaptor • Compatible with all 1" arbor lathes • Must mount with the adaptor and machined side of the rotor toward the lathe for twin cutter to align properly
- Order No. **CRA-2004** Jobber \$229.99

Many more products for Tire Changers are available online at goodson.com/TireChanger



Mount / Demount Head For COATS® Tire Changers

- Nylon Head for COATS® 5000, 6000 & 7000 series rim clamp tire changers
- Requires 182767 or 183812 taper end shaft (available online)
- Order No. **GT-18306** Jobber \$21.99



Replacement Inflator Hoses

- For most popular tire changers

Description	Jobber	Order No.
Corgi 60"L ¼" Hose, ½ MPT x Euro Coupling	\$12.99	TIH-00012
Corgi 60"L ¼" Hose, MPT x Euro Coupling	13.99	TIH-00014
Coats 60"L ¼" Hose, MPT x Euro Coupling	11.99	TIH-00015
FMC 52"L ¼" Hose Female Swivel x Euro Coupling w/guard	17.99	TIH-00020
Hunter 60"L ¼" Hose ¼" MPT x ¼" MPT	11.99	TIH-00025
Euro Coupling for Hunter Hose	5.99	TIH-202

More available online at goodson.com/TireChanger



Brake Lathe Tools



For GM 4x4 ('92 & later), Dodge Ram ('94 & later) Ford 1-ton ('98 & later)

GT-29495

Late Model Rotor Adaptor

- Turn late model ¾ & 1-ton rotor assemblies without disassembly • Locates from the rear bearing flange • Mounts to any 1" arbor brake lathe
- One-piece adaptor with four bolts

Description	Jobber	Order No.
Rotor Adaptor	\$199.99	GT-29495
Replacement Bolt Set (4 Pc.)	15.99	GT-29495-SET

Truck Adaptor Sets For 1" Arbors

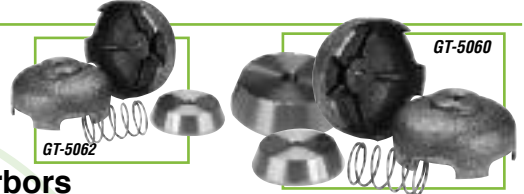

Description	Jobber	Order No.	Incl.
Standard Truck Set	\$189.99	GT-5062	▼
Master Truck Set	269.99	GT-5060	▼
Centering Cones			
3.750" x 5.125"	59.99	GT-5053	1 1
4.500" x 5.500"	59.99	GT-5052	
5.000" x 6.125"	69.99	GT-5054	1
Bell Clamps			
6.500" OD	69.99	GT-5055	1 2
7.750" OD	79.99	GT-5056	1
Heavy-duty Spring	8.99	GT-5059	1 1

Buy a case of 12 (any combination), **SAVE 10%**



Ceramlub™ rated up to 2800°F

Pastelub™ rated from -300°F to 2400°F

Brake Lubes

These synthetic lubricants will make your brake jobs easier and your customers happier. **Silencer™ Brake Spray** is the backbone of this trio. Use silencer spray on your rotors and other contact surfaces. The revolutionary metalizing treatment is OE approved and is effective from -100°F to +2000°F. **Ceramlub-2800™** contains ceramic pressure solids and anti-corrosive agents. It is specially designed for use on caliper slides, rubber seals and O-Rings. **Pastelub™** is OE recommended and won't melt, rub or wash off brake parts. It contains no silicone or petroleum. It is recommended for use on the back of brake pads.

Description	Jobber	Order No.	Incl.
Brake Lube TRI-PAK	\$42.99	TMPK-3	▼
Silencer™ Brake Spray (Aerosol)	15.99	BS-12	1
Ceramlub-2800™ Synthetic Lubricant (purple)	15.99	CBL-2800	1
Pastelub™ Hi-Temp Lubricant (gray)	15.99	BPL-2400	1

MIX OR MATCH TO MAKE A CASE OF 12

same day shipping on orders placed by 7pm (central)

CYLINDER HEAD REBUILDING
CLEANING, ASSEMBLY & SAFETY
SHORT BLOCK REBUILDING
FLYWHEEL GRINDING
BRAKE & ALIGNMENT TOOLS
MEASURING TOOLS
OFFROAD BIKE, ATV HARD PARTS
V-TWIN HARD PARTS

Alignment Tools & Supplies

GOODTOOL
now exclusively from Goodson



**Buy 2
Wheel Clamps,
save 10%**

**Buy 4
Wheel Clamps,
save 15%**



Universal Wheel Clamp

- Adapts to aluminum and steel wheels
- Screw type clamping • 4-point contact
- Hunter style feet (included) grip almost any wheel style
- Replacement feet for additional applications sold separately (see chart below) • 4 required for clamp

Application	Rim Size	Jobber	Order No.
Automotive (1)	10" - 19"	\$229.99	GT-8069
Truck (1)	16" - 26"	259.99	GT-8070
Replacement Feet	Qty. Per Pack		
1 Aluminum for Rimless Wheels	4	\$26.99	GT-522-4
	1	6.99	GT-522
2 Aluminum Wheels	4	32.99	GT-562-4
	1	8.99	GT-562
3 Extended for Dual Rear Wheels	4	53.99	GT-562-EXT-4
	1	13.99	GT-562-EXT

Fits all but Truline - call for more information



Ford Light Truck Camber/Caster Cam Bolt Kit

- Replaces non-adjustable factory system
- Adjustment range: $\pm 2.5^\circ$
- 2 per package
- Adjusts one side • Fits 1997-2003 Ford F-150 and 1997-2002 Expedition and Lincoln Navigator
- Order No. **FA-42778** Jobber \$21.99



**Many More
Alignment Tools
& Supplies are available at
www.goodson.com**

We don't have enough room in this catalog to include all of the alignment tools you can now get from Goodson. For our complete selection visit www.goodson.com/alignment

3.15" / 80mm diameter
magnet



Intercomp

Caster/Camber Bubble Gauge with Magnetic Adaptor

- Magnetic adaptor holds gauge for hands-free operation
- Measures $\pm 6^\circ$ of camber and $\pm 8^\circ$ of caster with 0.2° accuracy • CNC-machined aluminum housing
- Easy-to-read bubble display
- Comes in plastic molded case for safe storage
- Order No. **GAT-102010** Jobber \$239.99

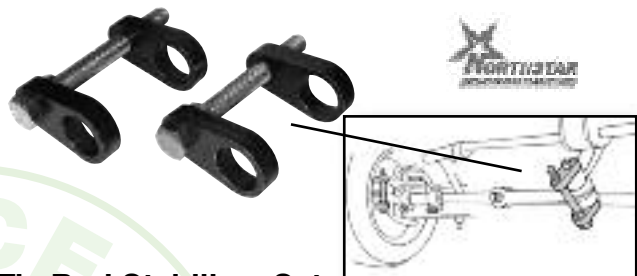

Tie Rod Stabilizer Set

- Centers tie rods in their sockets when setting toe. Helps to obtain a straight steering wheel to ensure proper steering performance and maximum tire life.
- Order No. **88-7205** Jobber \$75.26

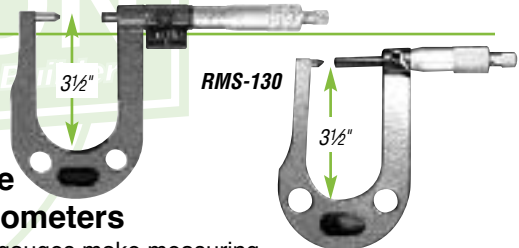

Swiss-style Rotor Micrometers

- Easy to read gauges make measuring rotors simple and accurate • Pointed anvils get into the grooves of the rotor for accurate measurements
- Case included

Scale	Range	Grad.	Jobber	Order No.
US Standard Mechanical	.300"-1.300"	.0001"	\$51.99	RMS-130
US Standard Mechanical Digital	.300"-1.300"	.0001"	79.99	RMS-230
Metric Mechanical Digital	7-33mm	.001mm	79.99	MDB-270



**Many More
Alignment Tools
& Supplies are available at
www.goodson.com**

We don't have enough room in this catalog to include all of the alignment tools you can now get from Goodson. For our complete selection visit www.goodson.com/alignment

GOODTOOL
now exclusively from Goodson



Disc Rotor & Ball Joint Gauges

- Measure rotor runout or ball joint wear
- Flexible arm can be locked into almost any position
- Unit includes: flexible arm, dial indicator (0"-1"), curved jaw locking pliers and case

Description	Jobber	Order No.
Economy Disc Rotor & Ball Joint Gauge	\$129.99	DIS-103
Central® Disc Rotor & Ball Joint Gauge	274.99	BRG-6450
Replacement Dial Indicator	28.99	EDI-1

Measuring Tools

GOODTOOL
now exclusively from Goodson



Electronic Digital Gauges

• Measure rotors & drums before turning or replacing

Range	Graduations	Arm Length	Jobber	Order No.
0" - 5.5"	.0005" / .01mm	3.50"	\$109.99	EDB-430
6" - 20.5"	.001" / .01mm	4.25"	329.99	EDB-530
Replacement Batteries			5.99	EDC-06B

GOODTOOL
now exclusively from Goodson

Drum Micrometer

- Easy-to-read dial • .005" graduations
- Also use to check for roundness
- Rebuild kit includes lens, gear cam, driver, washers, pins and plunger springs

Description	Jobber	Order No.
Micrometer (6" to 16½")	\$349.99	8500
Checking Gauge	129.99	9582
Extension Shaft (6" to 26")	179.99	8539
Rebuild Kit	49.99	9935

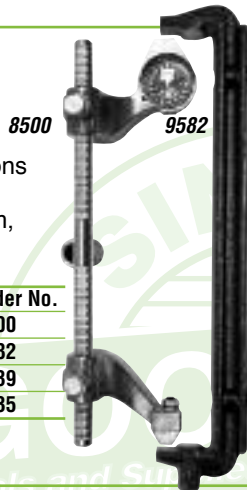

New!

Portable Ra & Rz Surface Roughness Tester

Use the Portable Surface Roughness Tester for a variety of surface roughness assessments including flat, inside/outside diameters and many difficult to gauge test surfaces. Featuring a durable cast housing and designed for shop use, this roughness tester will provide years of reliable and accurate surface finish assessments. See page 44 for complete specifications and additional uses. Order No. **PST-4** Jobber \$1,999.99



New!

Rod Bolt Stretch Gauge

This rod bolt stretch gauge is accurate to .001" and features a 1½" dial gauge. Heavy-duty tension spring for repeatable accuracy. For bolts from 1" to 2½" long.

Description	Jobber	Order No.
Rod Bolt Stretch Gauge	\$69.99	RBSG-3
Optional Contact Point	8.49	ERBG-3T



American Made



Leak-Down Tester

- Apply air pressure in spark plug hole • Compare supply psi to cylinder psi • Includes 14mm & 18mm adaptors

Description	Jobber	Order No.
Leak Down Tester	\$99.99	LDT-50
Replacement Hose	25.29	LDT-HOSE
10mm Adaptor	12.79	LDT-10MM
12mm Adaptor	12.79	LDT-12MM

Tech Tip Listen to where air is leaking. Leakage at the carburetor indicates bad intake valves. Leakage at the tail pipe shows bad exhaust valves. Worn rings or cylinders are indicated from leakage at the dipstick and leakage at the radiator cap points to block problems.

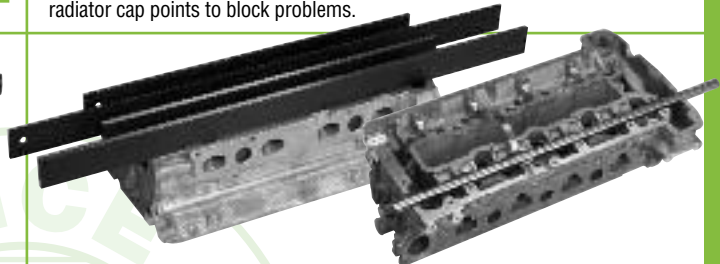

Precision Straight Edges & Warp Gauge

Description	Jobber	Order No.
24" straightedge, 1 precision edge	\$ 54.99	PSE-24
35" straightedge, 1 precision edge	79.99	PSE-100
24" straightedge, 2 precision edges	154.99	DIS-20
35" straightedge, 2 precision edges	167.99	DIS-30
26" Round Warp Gauge ¾" dia. tool steel, 26" long	125.99	EWG-100

12" Feeler Gauges

- Use to measure piston-to-wall clearance when honing, to find ring end gap and to check cylinder heads with a straight-edge
- Also useful for shimming while straightening heads and for machine set-ups

	Jobber	Order No.	
Complete Kit	\$43.99	FE-KIT	▼
Thick .0015"	5.99	FE-0015	x
.0020"	5.99	FE-002	x
.0030"	5.99	FE-003	x
.0040"	5.99	FE-004	x
.0050"	5.99	FE-005	x
.0060"	5.99	FE-006	x
.0070"	5.99	FE-007	x
.0080"	5.99	FE-008	x
.0090"	5.99	FE-009	x
.0100"	5.99	FE-010	x
.0150"	5.99	FE-015	x
.0200"	5.99	FE-020	x

6 Pc. Telescoping Gauge Set

- Compress spring plunger and lock by twisting handle • Insert into bore and release plunger – it will expand to fit • Lock again and remove • Measure with a micrometer • Double plunger design for consistent measuring
- Long-lasting finish
- Size range: 5/16" - 6"
- Order No. **MTG-6** Jobber \$149.99

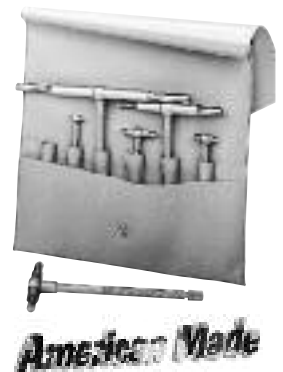

American Made

CYLINDER HEAD REBUILDING
CLEANING, ASSEMBLY & SAFETY
SHORT BLOCK REBUILDING
FLYWHEEL GRINDING
CRANKSHAFT/ FLYWHEEL GRINDING
BRAKE & ALIGNMENT TOOLS
MEASURING TOOLS
OFFROAD BIKE, ATV HARD PARTS
V-TWIN HARD PARTS

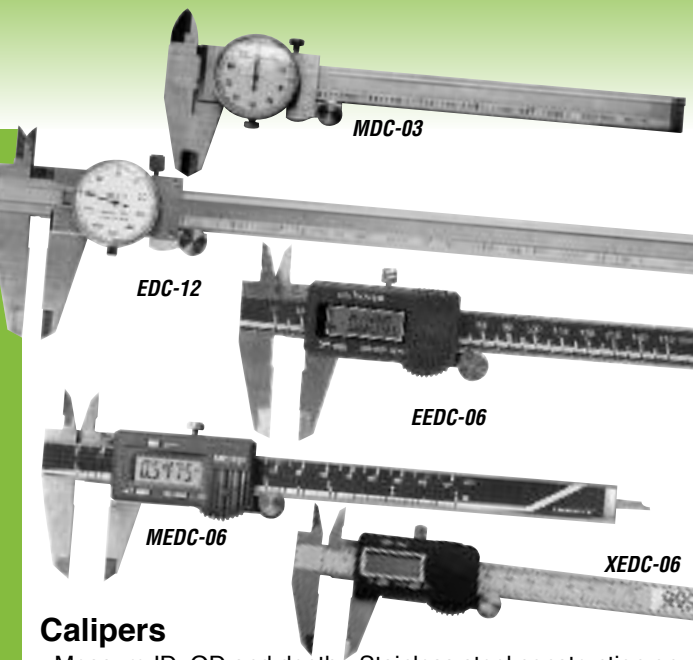

Calipers

- Measure ID, OD and depth • Stainless steel construction on all models • Electronic digital micrometers measure in both standard and metric

Dial Calipers (include case)

Range	Revolutions	Accuracy	Jobber	Order No.
0" to 6"	.100" per	.001"	\$ 59.99	MDC-03
0" to 12"	.100" per	.001"	84.99	EDC-12

Digital Calipers (include 1-battery and case)

Range	Accuracy	Jobber	Order No.
0" to 6"	.0005"	\$ 59.99	EEDC-06
0" to 6"	.0005"	199.99	MEDC-06
0" to 6"	.0005"	43.99	XEDC-06
Replacement Battery		6.99	EDC-06B

EDI-1 Revolution counter

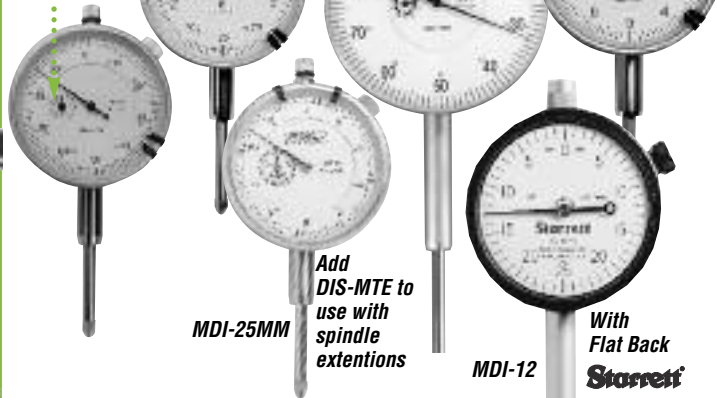

Dial Indicators

- All models feature adjustable bezel for zero settings
- Lug back with 1/4" hole • Shatter resistant crystal

Travel	Dial Dia.	Stem Length	Graduations	Jobber	Order No.
1"	2"	1"	.001"	\$ 28.99	EDI-1
1"	2"	1"	.0005"	34.99	EDI-0005
25mm	2"	1"	.01mm	154.99	MDI-25MM
2"	3"	2"	.001"	66.99	MDI-2
.050"	2"	1"	.0001"	69.99	MDI-110
.125"	2"	12"	.001"	299.99	MDI-12

Spindle Extensions (for use with Dial Indicators above)

1 1/2"	\$ 7.49	DIS-1.5
2 1/2"	11.79	DIS-2.5
3"	14.79	DIS-3.0

Metric Dial Indicator Point Adaptor (2.5mm to 4x48TPI) 11.79 **DIS-MTE**



Deck Bridge Tools

- Verify deck height without removing block from roll over fixture • Flat anvil surface makes full contact • Use Deck Bridge with 1 or 2 dial indicators

Description	Jobber	Order No.
Deck Bridge (4 1/2" span)	\$ 79.99	MDBS-2
Dial Indicator (12" OAL)	299.99	MDI-12
Dial Indicator Anvil	19.99	MDI-12A

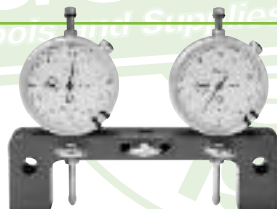

MBR-1

Magnetic Mounting Bases for Dial indicators

Description	Jobber	Order No.
Stiff Arm Stand (7 1/2" tall, 6 1/2" long, base: 1 7/8"x1 7/8"x2 1/4") Posts and arms adjust. Locks in place with a single lever	\$62.99	MBR-1
Flexible Arm Stand Adjusts easily and locks tightly in any position. 150 lbs. of magnetic force. Locks in place with a single lever	\$99.99	MFB-1

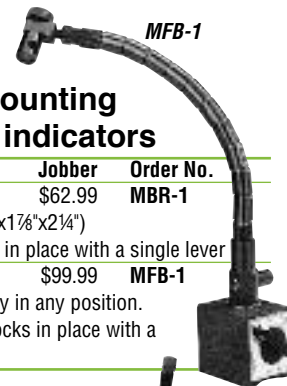

MFB-1

Valve Seat Height Gauge

- Confirm seat height to fire deck location
- Adjusts for all popular seat diameters • Accurate to .001"
- Seat contact probe aligns on valve seat while gauge rides along the fire deck • Pilot aligns in valve guide
- Adjustable to fit popular seat diameters from .750" to 3.00"

Description	Fits Pilot	Jobber	Order No.
Valve Seat	.375"	\$92.99	VSHG-375
Height Gauge Kit	.385"	92.99	VSHG-385
	.437"	92.99	VSHG-437
Replacement Dial Indicator		28.99	EDI-1

Includes Dial
Indicator

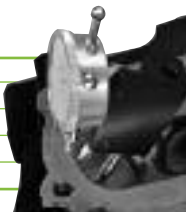

Pushrod Concentricity Checker

You won't believe how easy it is to check whether or not you have bent pushrods! Simply place the pushrod in question into the bracket on the tester and rotate it. If there's any variation in the concentricity, the gauge will show it. Order No. **PCC-100** Jobber \$29.99

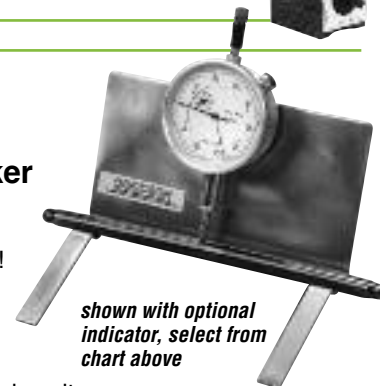

shown with optional
indicator, select from
chart above

Micrometers

Conventional Micrometers

- Carbide measuring faces for precision and durability
- .001" markings
- Vernier scale
- Ratchet stop, positive lock
- Baked enamel finish
- Each micrometer includes checking standard & case



Range	Jobber	Order No.
0"-1"	\$132.99	MMIC-01
1"-2"	154.29	MMIC-12
2"-3"	169.99	MMIC-23
3"-4"	199.79	MMIC-34
4"-5"	212.29	MMIC-45

Economy Micrometers

- Precision ground carbide anvil parallel to within .00005"
- .0001" graduations
- Set includes wood storage case

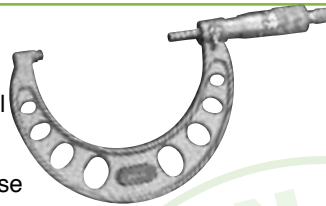

Description	Range	Jobber	Order No.	Incl.
Economy Micrometer Set (wood storage case)		\$199.99	EMS-06	▼
Individual Micrometers	0"-1"	31.99	EMIC-01	x
	1"-2"	34.99	EMIC-12	x
Each micrometer	2"-3"	36.99	EMIC-23	x
includes a standard,	3"-4"	39.99	EMIC-34	x
spanner wrench & case	4"-5"	44.99	EMIC-45	x
	5"-6"	47.99	EMIC-56	x



Metric Micrometer Set

- Graduations: 0.01mm • Carbide measuring faces
- Ratchet thimble and locking nut
- Includes 4 micrometers, 3 standards and storage case
- Order No. **MMS-100** Jobber \$159.99

Mechanical Read-Out Micrometer

- Gear-drive scale measures to .001" • Vernier scale to .0001" • Hardened spindle & anvil, lock and ratchet
- Each micrometer includes case and standard



Description	Jobber	Order No.	Inc.
4 Pc. Set	\$209.99	DMIC-4	▼
Individual Micrometers			
0" - 1" Range	\$76.99	DMIC-01	x
1" - 2" Range	76.99	DMIC-12	x
2" - 3" Range	76.99	DMIC-23	x
3" - 4" Range	76.99	DMIC-34	x

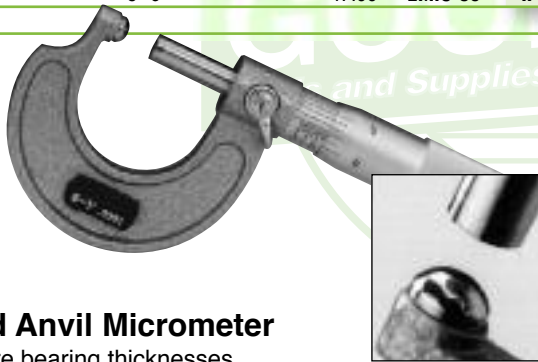

Round Anvil Micrometer

- Measure bearing thicknesses
- Ratchet spindle • 0-1" range • Precise to .0001"
- Order No **MIC-01-B** Jobber \$99.99

Valve Seat Run-Out Gauge

- Measure run-out to .001"
- Hardened guide bushings and contact pilot • Quick thumb screw set-up • Jeweled bearing indicator reads to ±.050" with .001" precision
- Range: 1.00" - 2.50"

Pilot Size	Jobber	Order No.
.375" / 9.53mm	\$139.99	VSG-375
.385" / 9.78mm	139.99	VSG-385



Shown with **MMIC-23** Micrometer and **MMCB-06** (both sold separately)

Micrometer Stand

- Heavy cast iron construction • Use to hold micrometers, standards or virtually anything you need an extra hand for
- Swivel head and padded jaws
- Order No. **MIC-FIX** Jobber \$21.99



Small Hole Gauge Set

- See if rebuilding or replacement is needed by checking actual guide wear • Check guide bosses for proper interference fit during replacement
- Check and maintain correct stem to guide ID clearance • 4-piece set has combined range of .125"-.500" / 3.2-12.7mm • Storage case included
- Order No. **SHG-5** Jobber \$121.29



Split Ball Bore Gauge

- Dial gauge with large contact area
- Measures quickly & accurately to .0001" (.0025mm) • Works in threaded or knurled guide IDs • Range: .280"-.400" • Easy to change contacts
- Order No. **MVG-34** Jobber \$599.99



CYLINDER HEAD
REBUILDING

CLEANING,
ASSEMBLY & SAFETY

SHORT BLOCK
REBUILDING

FLYWHEEL GRINDING
CRANKSHAFT/

BRAKE & ALIGNMENT
TOOLS

MEASURING
TOOLS

OFFROAD BIKE, ATV
HARD PARTS

V-TWIN
HARD PARTS

**Full Service
...FAST!!**



"If you need engine building tools and supplies, you need Goodson! We're dedicated to providing you with the best quality products, the best value and the best service in the industry."
- Michele, Customer Service Representative - 8 years of service

Exclusive

Dial Bore Gauge Setting Fixture

- Fast, accurate setting from 2" to 6"
- Billet steel construction with a tool black finish
- Sets most popular bore gauges including Mitutoyo™, Phase II, Fowler and Peacock • Will not fit Sunnen Bore Gauges (see page 135 for Sunnen setting fixture)
- .001" increment micrometer • 3 setting standards (1", 2" & 3") included • Carrying case included
- Order No. **DBG-FIX** Jobber \$469.99

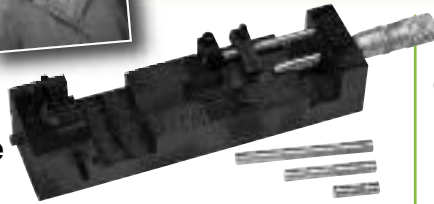

90° Dial Bore Gauges

- Measure cam bores, main bores and other hard-to-reach areas directly
- No passing through other bores to measure inboard journals • .100" travel in .0001" increments
- Metric has 3mm travel in .01mm resolution
- 3 spacers, 11 probes and case included

Range	Graduations	Jobber	Order No.
1.4" - 2.0"	.0001" .0025mm	\$249.99	MCB-1421
2.0" - 6.0"	.0001" .0025mm	339.99	MCB-90
35-50mm	.01mm	199.99	DMBG-3550
50-160mm	.01mm	199.99	DMBG-50160

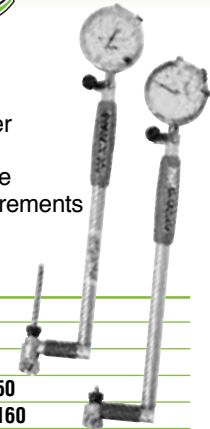

Cylinder Dial Bore Gauge Sets

- Easy to read • Insulated grip
- Measure cylinders up to 9" deep
- Graduations: 0.0005" • Self-centering
- Chrome plated handle
- Includes extension holder and fitted case

Range	Jobber	Order No.
0.7" - 1.5" (18-38mm)	\$129.99	FBG-7
1.4" - 6.0" (35-150mm)	149.99	FBG-146



Economy Bore Gauges

- Includes: .050" travel indicator, 3 spacers (.100", .050" and .020"), probes and case

Description	Range	Probes	Resolution	Jobber	Order No.
Standard US	2" - 6"	11	.0005"	\$109.99	EBG-265
Standard US	2" - 6"	11	.0001"	169.99	EBG-261
Metric	35 - 160mm	12	.01mm	159.99	MCBG-160
11 Pc. Replacement Spacer Set				36.99	EBG-ANVILS



Dial Bore Gauge Set

- Rugged bore gauge with protected dial
- Carbide tipped contact points
- .0001" (.001mm) graduations • Indication stability: .00008"
- Accuracy: .0002" • Shoe can be rotated for a fresh wear surface • Sets up with a standard micrometer (see page 123)

Range	Description	Jobber	Order No.
2.0"-6.0"	11 anvils and 4 spacers	\$529.99	MMCB-06
Replacement Spacers			
	.020"	9.29	MMCB-06-020
	.040"	9.29	MMCB-06-040
	.080"	9.29	MMCB-06-080
	.120"	9.29	MMCB-06-120
Replacement Lens		19.79	MMCB-06LENS
Replacement Dial Indicator		194.29	MMCB-06IND
Replacement Dial Cover		22.79	MMCB-06COVER

Internal Dial Caliper Gauge

- Ideal for measuring, matching port runners & bowl measurements
- Each critical measurement duplicates exactly
- Hardened contact surfaces

Range	Jobber	Order No.
.375" - 1.375"	\$84.99	EDC-375
.750" - 1.750"	84.99	EDC-750
1.125" - 2.125"	84.99	EDC-125
1.875" - 2.875"	84.99	EDC-187



Teak Bore Gauge Stand

You'll always be able to find your bore gauge when you store it on this solid teak stand. The organizer rack is designed to keep your anvils organized and protected and is included with the rack.
Order No. **BGS-1** Jobber \$14.99



Bore gauge sold separately

Internal Electronic Caliper

- Ideal for measuring, mating port runners and bowl measurements • Hardened contact surfaces
- Robust housing with large LCD display
- Reading: .01"/.3mm/1/64ths
- Spring loaded locking nut
- Order No. **IEC-56** Jobber \$54.29



New!

CYLINDER HEAD REBUILDING
CLEANING, ASSEMBLY & SAFETY
SHORT BLOCK REBUILDING
CRANKSHAFT/ FLYWHEEL GRINDING
BRAKE & ALIGNMENT TOOLS
MEASURING TOOLS
OFFROAD BIKE, ATV HARD PARTS
V-TWIN HARD PARTS

Measuring Tools



GOODSON Replacement Gauge For AG-300

- Order No. **AG-GAUGE** Jobber \$89.99



Sunnen® AG-Series Precision Gauge

- Dial reads directly in "tenths" (.0001") • Checks rod journal bore for distortion • Measures size instantly
- Wear-compensated gauge points assure permanent accuracy • Rugged construction – all moving parts are enclosed in the housing • Includes Point Sets listed below (optional point sets available, call for information)
- Replacement Gauge swaps easily with the original

Description	Jobber	Order No.
.375" - 3.375" (9.5 - 85.7mm) Range Gauge	\$2,629.99	AG-300
Standard Point Set (.720" - 1.530" Range)	54.99	AG-210
Medium Point Set (1.50" - 2.25" Range)	79.99	AG-620
Large Point Set (1.932" - 2.687" Range)	79.99	AG-630
Replacement Gauge (not OE Sunnen)	89.99	AG-GAUGE

Point sets will NOT fit AG-gauges lower than Serial No. 4000

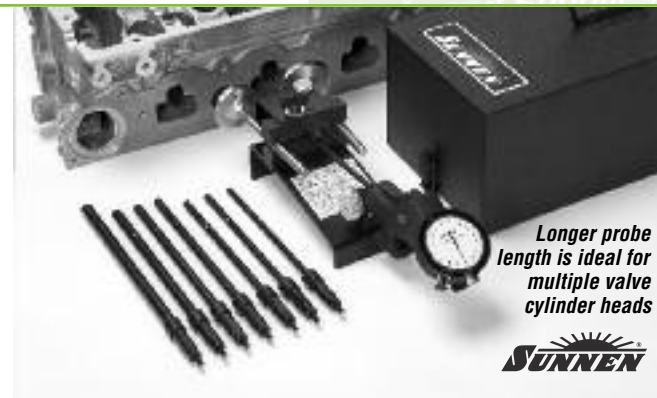

Longer probe length is ideal for multiple valve cylinder heads



Valve Guide Gauge Set

- Set up and measure valve guide IDs quickly and easily
- Complete set includes fixture and three probes (.312", .344" and .375") • Dial calibrated in .0002" increments
- Centralizing setting fixture and metal storage case with spaces for all components

Description	Jobber	Order No.	Incl.
Valve Guide Gauge Set	\$1,769.99	P-310	▼
Valve Guide Probes			
Size	Range In.	mm	
.236"	.224" - .264"	5.69 - 6.71	\$319.99 P-236
.250"	.238" - .278"	6.05 - 7.05	289.29 P-250
.281"	.269" - .309"	6.83 - 7.85	289.29 P-281
.312"	.300" - .340"	7.62 - 8.64	289.29 P-312 x
.344"	.332" - .372"	8.43 - 9.45	289.29 P-344 x
.375"	.363" - .403"	9.22 - 10.24	289.29 P-375 x
.438"	.426" - .466"	10.82 - 11.84	303.99 P-438
.500"	.488" - .528"	12.40 - 13.41	329.29 P-500



Setting Fixture

- Use with GA-2121, GA-2125, GR-2241 and GR-2245 Dial Bore Gauges (below)
- For 2" to 6" diameters • Incorporates a tenth-reading micrometer head with precision carbide anvil • Ring gauge checking standard included • Precision standards in 1" increments • Setting master has rugged, stress-relieved, cast iron base • May be used without removing from protective case • Order No. **CF-1126** Jobber \$1,789.99

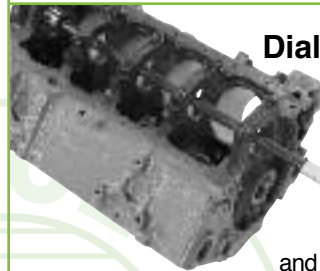

Dial Bore Gauges with Retractable Centralizers



- Retractable self-centering gauging head mechanism
- Ideal for measuring bores typical of main bearing saddle and camshaft bearing bores
- Shipping weight: 5 lbs. • Diameter range: 2" to 6" • 24" reach

Bore Gauge with Retractable Centralizers	Jobber	Order No.
.0001" graduations	\$1,199.99	GR-2241
.0005" graduations	1,199.99	GR-2245



Dial Bore Gauges

- For cylinders, sleeves, large connecting rods and many other gauging jobs • Diameter range: 2" to 6" • 12" reach • Self-aligning and self-centering
- Carbide contact points • Insulated grip eliminates "drift"
- Includes molded case with extension points & wrenches

Dial Bore Gauge	Jobber	Order No.
.0001" graduations	\$989.29	GA-2121
.0005" graduations	989.29	GA-2125



Checking Standards

- Use to set up dial indicators in special application gauging and to check micrometer accuracy
- Made of hardened, ground and lapped tool-steel
- Heat insulated covers
- Meet or exceed federal accuracy specifications

Length	Jobber	Order No.
1"	\$9.99	MCS-1
2"	9.99	MCS-2
3"	9.99	MCS-3



CYLINDER HEAD REBUILDING

CLEANING, ASSEMBLY & SAFETY

SHORT BLOCK REBUILDING

CRANKSHAFT/ FLYWHEEL GRINDING

BRAKE & ALIGNMENT TOOLS

MEASURING TOOLS

OFFROAD BIKE, ATV HARD PARTS

V-TWIN HARD PARTS

From our customers:



"In 2006, I took 3rd place in 2 Wheelspeed Hot Street Class but had valve train failures throughout the year. I have tried several brand named components but still had failures. In 2007, when I started using AV&V components, I had no valve train failures."

-Ken Carlock, Middle of Nowhere Cycles, Tower Hill, Illinois

Additional Applications Online at www.goodson.com



AV&V Extreme Duty Valves for Off-Road Motorcycles & ATVs

These superb valves are one-piece forged from a racing-grade stainless steel alloy. Their profile has been optimized to reduce the weight and maximize airflow. Liquid nitriding creates a valve that is smoother and stronger than traditional OE or replacement valves.

Application	Type	Head Dia.	OAL	Stem Dia.	Back Angle	Jobber	Black	Chrome
Honda CRF 250R (2004-2007)	Exhaust	26.00mm	82.15mm	4.97mm	20°	\$21.99	MAV-1001	
	Exhaust	27.00mm	82.15mm	4.97mm	20°	21.99	MAV-1002	
	Intake	31.00mm	83.30mm	4.98mm	19°	21.99	MAV-1003	Δ
	Intake	32.00mm	83.30mm	4.98mm	19°	21.99	MAV-1004	Δ
CRF 250R (2008-2009)	Exhaust	26.00mm	82.15mm	4.47mm	20°	21.99	MAV-1005	
	Intake	31.00mm	83.30mm	4.98mm	19°	21.99	MAV-1003	Δ
CRF 450R (2002-2008)	Exhaust	31.00mm	84.35mm	4.97mm	20°	21.99	MAV-1011	
	Intake	36.00mm	84.25mm	5.48mm	19°	21.99	MAV-1008	Δ
	Intake	37.00mm	84.25mm	5.48mm	19°	21.99	MAV-1009	Δ
CRF 450R (2009-2011)	Exhaust	30.00mm	80.52mm	4.97mm	20°	21.99	MAV-1016	
	Exhaust	31.00mm	80.64mm	4.97mm	20°	21.99	MAV-1017	
	Intake	36.00mm	78.61mm	4.98mm	19°	21.99	MAV-1014	Δ
	Intake	37.00mm	78.63mm	4.98mm	19°	21.99	MAV-1015	Δ
TRX 450R (2004-2005)	Exhaust	30.00mm	84.35mm	5.47mm	20°	21.99	MAV-1012	
	Exhaust	31.00mm	84.35mm	5.47mm	20°	21.99	MAV-1013	
	Intake	36.00mm	84.25mm	5.48mm	19°	21.99	MAV-1008	Δ
	Intake	37.00mm	84.25mm	5.48mm	19°	21.99	MAV-1009	Δ
TRX 450R (2006-2009)	Exhaust	30.00mm	84.35mm	4.97mm	20°	21.99	MAV-1010	
	Exhaust	31.00mm	84.35mm	4.97mm	20°	21.99	MAV-1011	
	Intake	36.00mm	84.25mm	5.48mm	19°	21.99	MAV-1008	Δ
	Intake	37.00mm	84.25mm	5.48mm	19°	21.99	MAV-1009	Δ
Kawasaki KX 250F (2003-2011)	Exhaust	25.00mm	79.51mm	4.47mm	20°	21.99	MAV-1101	Δ
	Exhaust	26.00mm	79.51mm	4.47mm	20°	21.99	MAV-1102	Δ
	Intake	31.00mm	79.51mm	4.48mm	19°	21.99	MAV-1103	Δ
	Intake	32.00mm	79.51mm	4.48mm	19°	21.99	MAV-1104	Δ
KFX 650/700/750 (2005-2009)	Intake	30.00mm	91.44mm	4.98mm	19°	21.99	MAV-1111	
Prairie - Brute Force - Teryx	Intake	31.00mm	91.44mm	4.98mm	19°	21.99	MAV-1112	
Suzuki RMZ 250 (2004 - 2006)	Exhaust	25.00mm	79.51mm	4.47mm	20°	21.99	MAV-1101	Δ
	Exhaust	26.00mm	79.51mm	4.47mm	20°	21.99	MAV-1102	Δ
	Intake	31.00mm	79.51mm	4.48mm	19°	21.99	MAV-1103	Δ
	Intake	32.00mm	79.51mm	4.48mm	19°	21.99	MAV-1104	Δ
RMZ 250 (2007 - 2010)	Exhaust	25.00mm	80.90mm	4.47mm	20°	21.99	MAV-1201	Δ
	Exhaust	26.00mm	81.02mm	4.47mm	20°	21.99	MAV-1202	Δ
	Intake	31.00mm	80.64mm	4.48mm	19°	21.99	MAV-1203	Δ
	Intake	32.00mm	80.74mm	4.48mm	19°	21.99	MAV-1204	Δ
LTR 450/450Z (2006-2009)	Exhaust	30.00mm	84.25mm	5.97mm	20°	21.99	MAV-1205	Δ
	Intake	36.00mm	81.91mm	5.48mm	19°	21.99	MAV-1207	Δ
	Intake	37.00mm	81.91mm	5.48mm	19°	21.99	MAV-1208	Δ
Yamaha YZ 450F & YZF 450/450R (2003-2009)	Exhaust	28.00mm	75.05mm	4.97mm	20°	21.99	MAV-1301	Δ
	Exhaust	29.00mm	75.05mm	4.97mm	20°	21.99	MAV-1302	Δ
	Intake	27.00mm	77.20mm	4.48mm	19°	21.99	MAV-1303	Δ
	Intake	28.00mm	77.20mm	4.48mm	19°	21.99	MAV-1304	Δ
	Intake	27.00mm	76.20mm	4.48mm	19°	21.99	MAV-1305	Δ (Center Valve)
	Intake	28.00mm	76.20mm	4.48mm	19°	21.99	MAV-1306	Δ (Center Valve)
YZ 450F (2010 - 2011)	Exhaust	30.00mm	83.58mm	5.47mm	20°	21.99	MAV-1307	Δ
	Exhaust	31.00mm	83.58mm	5.47mm	20°	21.99	MAV-1308	Δ
	Intake	36.00mm	85.98mm	5.48mm	19°	21.99	MAV-1309	Δ
	Intake	37.00mm	85.98mm	5.48mm	19°	21.99	MAV-1310	Δ
Grizzly/Raptor 700 (2006-2009) Valves are .040" longer to correct the rocker arm geometry. Stock springs must be shimmed to retain stock pressure use # MVSS-1310-20. Must use spring kit # MVSK-1318 when using aftermarket camshafts with higher lift.	Exhaust	32.00mm	96.90mm	5.97mm	20°	26.99		MAV-1312
	Exhaust	33.00mm	96.90mm	5.97mm	20°	26.99		MAV-1313
	Exhaust	34.00mm	96.90mm	5.97mm	20°	23.99		MAV-1314
	Intake	38.00mm	103.04mm	5.98mm	19°	23.99		MAV-1315
	Intake	39.00mm	103.04mm	5.98mm	19°	26.99		MAV-1316
	Intake	40.00mm	103.04mm	5.98mm	19°	26.99		MAV-1317

Δ indicates valves that require use of Extreme Duty Valve Springs (p.128) due to increased pressure requirements. See www.goodson.com for more information.

CYLINDER HEAD REBUILDING
CLEANING, ASSEMBLY & SAFETY
SHORT BLOCK REBUILDING
CRANKSHAFT/ FLYWHEEL GRINDING
BRAKE & ALIGNMENT TOOLS
MEASURING TOOLS
OFFROAD BIKE, ATV HARD PARTS
V-TWIN HARD PARTS

Valve Guides for Offroad Bikes & ATVs



Additional Applications Online
at www.goodson.com



Valve Guides for Metric Engines

- AV&V's Manganese bronze alloy allows you to fit the valve at a tighter clearance for better heat dissipation and longer life
- Tapered and radiused nose for easier installation and better air flow
- Unique Super Grip Valve seal section use either OEM style or viton seals
- CNC machined
- Ready to be reamed to size with our carbide reamers (p. 134)

Application	Type	OD	ID	Jobber	Order No.
Honda CRF 150R (2007-2008)	Intake	9.05mm	4.50mm	\$9.49	MVG-1020-00
	Exhaust	9.05mm	4.50mm	9.49	MVG-1021-00
CRF 250X (2004-2007)	Intake	10.06mm	5.00mm	9.49	MVG-1024-00
	Exhaust	10.06mm	5.00mm	9.49	MVG-1025-00
TRX 450EX (1999-2007)	Intake	11.05mm	5.50mm	9.49	MVG-1040-00
	Exhaust	11.05mm	5.50mm	9.49	MVG-1040-00
TRX 450EX .001" Oversize	Intake	11.08mm	5.40mm	9.49	MVG-1040-01
	Exhaust	11.08mm	5.40mm	9.49	MVG-1040-01
CRF 450 (2002-2008) and TRX 450R (2006-2009)	Intake	11.06mm	5.50mm	9.49	MVG-1050-00
	Exhaust	11.06mm	5.00mm	9.49	MVG-1051-00
TRX 450R (2004-2005)	Intake	11.06mm	5.50mm	9.49	MVG-1050-00
	Exhaust	11.06mm	5.50mm	9.49	MVG-1055-00
Kawasaki KX 250F (2003-2009)	Intake	9.57mm	4.50mm	9.49	MVG-1110-00
	Exhaust	9.57mm	4.50mm	9.49	MVG-1110-00
Suzuki LTR 450/450Z (2006-2009)	Intake	10.58mm	5.50mm	9.49	MVG-1210-00
	Exhaust	10.58mm	5.50mm	9.49	MVG-1210-00
Yamaha YFZ 450R (2003-2009) 5-Valve	Intake	11.06mm	5.50mm	9.49	MVG-1310-00
	Exhaust	26.00mm	5.00mm	9.49	MVG-1311-00
YFZ 450R (2010-2011) 4-Valve	Intake	11.06mm	5.50mm	9.49	MVG-1055-00
Grizzly/Raptor 700 (2006-2009)	Intake	11.56mm	6.00mm	9.49	MVG-1330-00
	Exhaust	11.56mm	6.00mm	9.49	MVG-1330-00

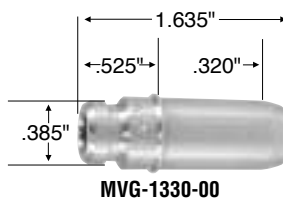
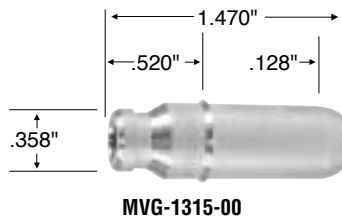
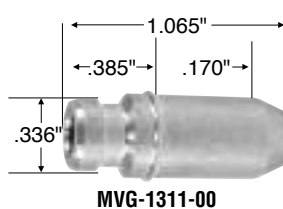
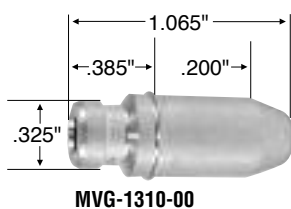
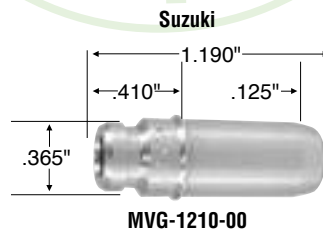
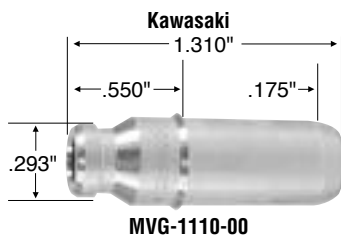
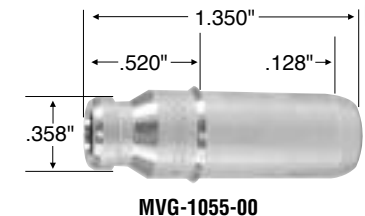
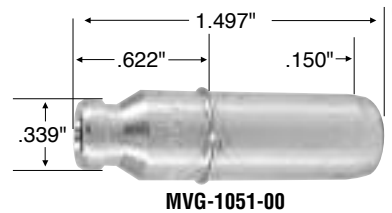
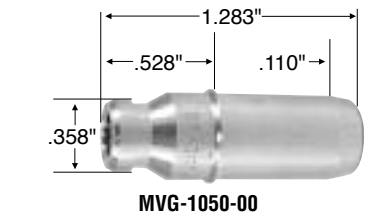
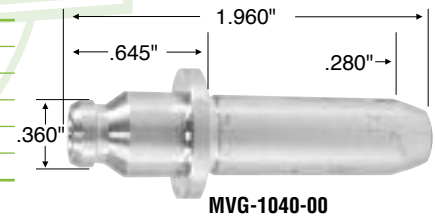
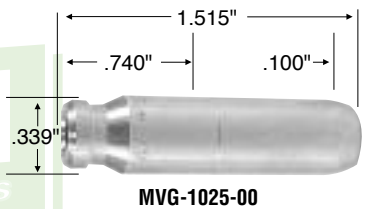
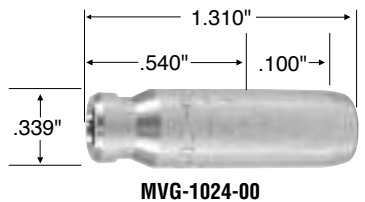
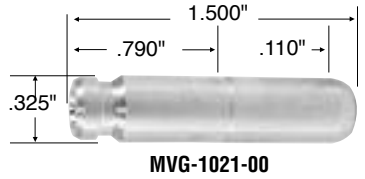
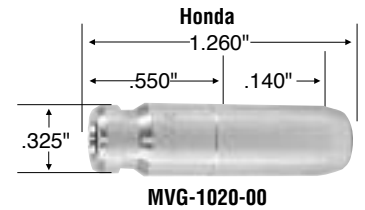

CYLINDER HEAD
REBUILDING

CLEANING,
ASSEMBLY & SAFETY

SHORT BLOCK
REBUILDING

CRANKSHAFT/
FLYWHEEL GRINDING

BRAKE & ALIGNMENT
TOOLS

MEASURING
TOOLS

OFFROAD BIKE, ATV
HARD PARTS

V-TWIN
HARD PARTS

**Full Service
... FAST!!**



"If any one of our products isn't completely satisfactory, we want you to send it back... we have a no hassle return policy. Fill out the Pre-Authorized Return Form, then ship the item back to us freight pre-paid within 30 days. We'll fix it, exchange it or refund your money by crediting your account."
- Nancy, Goodson Purchasing and Inventory Control Manager, 17 years of service



Extreme Duty Valve Spring Kits

The springs are manufactured from ultra clean high silicon Kobe alloy wire then micro shot peened and nitrated. They are designed to be used with high performance cams or steel valves that replace Titanium valves. NOTE: When Changing OEM titanium valves for steel valves, you must also upgrade your springs for AV&V's Extreme Duty Springs due to the need for higher pressure and toughness.

Honda CRF 250R / X (2004-2019) for Steel Valves

Spring Model	Max. Lift	Seat Pressure	Open Pressure	Coil Bind Height	Retainers	Lower Collars	O.D.	I.D.	Jobber	Order No.
Intake	.380"	38#@1.309"	116#@0.929"	0.870"	Use Stock Units	Use stock or OE	0.760"	0.514"	\$89.99	
Exhaust	.401"	43#@1.525"	168#@1.124"	1.045"	Use Stock Units	Use stock or OE	0.780"	0.510"		MVSK-1006

Valve Shims available for the above. Order No. **MVSS-1010-20** OD: .740" ID: .440" / Thickness: .020" (Pkg/20 shims) Jobber \$8.99

Intake Springs Only, use part number **MVSK-1006-i** Jobber \$59.99



Honda CRF 450/TRX 450 (2002-2009) for Steel or Titanium Valves

Spring Model	Max. Lift	Seat Pressure	Open Pressure	Coil Bind Height	Retainers	Lower Collars	O.D.	I.D.	Jobber	Order No.
Intake	.435**	51#@1.337"	179#@1.902"	0.850"	Use Stock Units	included	0.934"	0.650"	\$89.99	For Steel Valves
Exhaust	.385"	52#@1.416"	179#@1.031"	0.960"	Use Stock Units	included	0.934"	0.650"		MVSK-1015
Intake	.435**	42#@1.337"	179#@1.902"	0.850"	Use Stock Units	included	0.934"	0.650"	89.99	For Titanium Vlvs
Exhaust	.385"	52#@1.416"	179#@1.031"	0.960"	Use Stock Units	included	0.934"	0.650"		MVSK-1015T

Valve Shims available for the above. Order No. **MVSS-1015-20** OD: .930" / ID: .478" / Thickness: .020" (Pkg/20 Shims) Jobber \$8.99

Intake Springs Only, use part number **MVSK-1006-i** Jobber \$59.99

Kawasaki KX 250F (2004-2006) and Suzuki RMZ 250 (2004-2006) for Steel Valves

Spring Model	Max. Lift	Seat Pressure	Open Pressure	Coil Bind Height	Retainers	Lower Collars	O.D.	I.D.	Jobber	Order No.
In. / Ex.	.397"	38#@1.317"	130#@.920"	0.835"	Use Stock Units	Use Stock Units	0.800"	0.560"	\$89.99	MVSK-1110

Kawasaki KX 250F (2007-2010) for Steel Valves

Spring Model	Max. Lift	Seat Pressure	Open Pressure	Coil Bind Height	Retainers	Lower Collars	O.D.	I.D.	Jobber	Order No.
In. / Ex.	.397"	38#@1.317"	130#@.920"	0.835"	included	included	0.800"	0.560"	\$89.99	MVSK-1111

This kit comes with hard anodized aluminum top retainers for the intake springs

Kawasaki KFX 650/700/750 (2005-2009) Prairie-Brute Force - Teryx for Steel Valves

Spring Model	Max. Lift	Seat Pressure	Open Pressure	Coil Bind Height	Retainers	Lower Collars	O.D.	I.D.	Jobber	Order No.
In. / Ex.	.444"	48#@1.364"	145#@.990"	0.870"	Use Stock Units	Use Stock Units	0.990"	0.690"	\$89.99	MVSK-1116

Intake Only Kit for Steel Valves. Order No. **MVSK-1116i** Jobber \$59.99

Suzuki RMZ 450/LTR 450 (2006-2009) for Steel or Titanium Valves

Spring Model	Max. Lift	Seat Pressure	Open Pressure	Coil Bind Height	Retainers	Lower Collars	O.D.	I.D.	Jobber	Order No.
Intake	.400"	44#@1.160"	141#@0.760"	0.710"	Use Stock Units	Use Stock Units	1.000"	0.730"	\$89.99	For Steel Valves
Exhaust	.400"	34#@1.160"	111#@0.760"	0.705"	Use Stock Units	Use Stock Units	0.910"	0.670"		MVSK-1217
Intake	.400"	37#@1.160"	134#@0.760"	0.710"	Use Stock Units	Use Stock Units	1.000"	0.730"	89.99	For Titanium Vlvs
Exhaust	.400"	34#@1.160"	111#@0.760"	0.705"	Use Stock Units	Use Stock Units	0.910"	0.670"	89.99	MVSK-1217T

Intake valve shims available for the above. Part number **MVSS-1210-20** OD: .942" / ID: .460" / Thickness: .020" (Pkg/20 shims) Jobber \$8.99

Exhaust valve shims available for the above. Part number **MVSS-1211-20** OD: .862" / ID: .460" / Thickness .020" (Pkg/20 shims) Jobber \$8.99

Yamaha YFZ 450 (2003-2009) for Steel or Titanium Valves

Valve Type	Max. Lift	Seat Pressure	Open Pressure	Coil Bind Height	Retainers	Lower Collars	O.D.	I.D.	Jobber	Order No.
For Steel	.380"	38#@1.060"	81#@0.680"	0.625"	Use Stock Units	Use Stock Units	0.756"	0.560"	\$89.99	MVSK-1317
For Titanium	.380"	32#@1.060"	75#@0.680"	0.625"	Use Stock Units	Use Stock Units	0.756"	0.560"	89.99	MVSK-1317T

Valve Shims available for the above. Part number **MVSS-1010-20** OD: .740" / ID: .440" / Thickness .020 (Pkg/20 shims) Jobber \$8.99

Yamaha Raptor / Grizzly 700 (2006-2009) for Steel Valves

Spring Model	Max. Lift	Seat Pressure	Open Pressure	Coil Bind Height	Retainers	Lower Collars	O.D.	I.D.	Jobber	Steel Valves Order No.
In. / Ex.	.460**	45#@1.450"	195#@0.950"	0.880"	R1318	included	1.105"	0.742"	\$155.99	MVSK-1318

This kit comes with hard anodized ALU-Ti retainers and jumbo valve keepers.

Valve Shims available for the above. Part number **MVSS-1310-20** OD: 1.090" ID: .460" Thickness: .020" (Pkg/20 shims) Jobber \$8.99

*Max lift with AV&V Valves is .500", otherwise it is .460" with stock valves.

CYLINDER HEAD REBUILDING
CLEANING, ASSEMBLY & SAFETY
SHORT BLOCK REBUILDING
CRANKSHAFT/ FLYWHEEL GRINDING
BRAKE & ALIGNMENT TOOLS
MEASURING TOOLS
OFFROAD BIKE, ATV HARD PARTS
V-TWIN HARD PARTS



MV-039-10 MV-023-10 MV-091-10 MV-047-10 MV-010-10

AV&V Viton Valve Seals for Offroad Applications

- Made from a special Viton compound, these seals can resist higher temperatures than regular Viton seals
- 10 per pack

Application	Guide OD	Stem Dia.	Order No.
Honda			
CRF 150R Intake & Exhaust (07-08)	.325"	4.5mm	MV-039-10
CRF 250R Intake & Exhaust (04-07)	.339"	5.0mm	MV-023-10
TRX400EX Intake & Exhaust (99-07)			
TRX/CRF 450R Intake (02-08)	.360"	5.5mm	MV-091-10
TRX/CRF 450R Exhaust (06-09)			
TRX/CRF 450R Exhaust (04-05)	.339"	5mm	MV-098-10
Yamaha			
YFZ 450 Intake & Exhaust (03-09)	.325"	4.5mm	MV-039-10
Suzuki			
LTR-450 Intake & Exhaust (06-09)	.360"	5.5mm	MV-091-10
Can Am			
DS 450 Intake & Exhaust (08)	.4360"	6mm	MV-047-10
Kawasaki			
KX 250F Intake (03-09)	.293"	4.5mm	MV-010-10

Jobber \$12.99



HVS-6MM HV-7MM HV-7MMOE HVS-421 HVS-531

HV-7MMOE

AV&V Viton Valve Seals for V-Twins

- Resist temperatures up to 50° higher than other viton seals • Evo/TC stock length guides need to be shortened with .420" Valve Seal Cutter (VSC-420312)

Size	Application	Guide OD	Stem Dia.	Qty.	Jobber	Order No.
6mm	V-Rod	8.5mm	6mm	20	\$18.99	HVS-6MM
7mm	Double Spring	.562"	7.0mm	20	28.99	HV-7MM
7mm	OE Replacement	.562"	7.0mm	20	28.99	HV-7MMOE
.421"	Evo / Twin Cam	.421"	.3125"	20	18.99	HVS-421
.531"	Evo / Twin Cam	.531"	.3125"	20	19.99	HVS-531



HSS-420 HSS-530312 HSS-530341 HSS-562 HSS-625

OE Style Valve Seals

Application	Guide OD	Stem Dia.	Qty.	Jobber	Order No.
Evo/Twin Cam	.420"	.312"	20	\$21.99	HSS-420
Evo/Iron Head Sportster (Intake)	.530"	.312"	20	21.99	HSS-530312
Iron Head Sportster (Exhaust)	.530"	.341"	20	21.99	HSS-530341
Pan/Shovel Head (1948-79)	.562"	.375"	20	21.99	HSS-562
Shovel Head (1980-84)	.625"	.375"	20	21.99	HSS-625

Valve Seat Inserts

- For Harley
- Easy to machine
- Effectively dissipates heat for consistent valve sealing
- Hardness increases during engine break-in • Radiused for easy installation



Replacement Valve Seats For Shovel Head 1200 & 1340

Application	OD	ID	Thickness	Jobber	Order No.
Exhaust	1.944"	1.570"	.400"	\$6.99	HVS-1944
Intake	2.135"	1.750"	.400"	6.99	HVS-2135

Oversize Seats For Shovel, Evolution & Twin Cam – machining required

OD	ID	Thickness	Jobber	Order No.
1.630"	1.180"	.385"	\$6.99	HVS-1630
1.757"	1.410"	.430"	6.99	HVS-1757
1.882"	1.530"	.410"	6.99	HVS-1882
2.008"	1.610"	.440"	6.99	HVS-2008
2.040"	1.700"	.425"	6.99	HVS-2040
2.070"	1.610"	.460"	6.99	HVS-2070
2.132"	1.800"	.460"	6.99	HVS-2132
2.163"	1.750"	.455"	6.99	HVS-2163

For Iron Head Sportster

Application	OD	ID	Thickness	Jobber	Order No.
Exhaust	1.757"	1.371"	.315"	\$6.99	HVS-1757S
Intake	2.068"	1.750"	.315"	6.99	HVS-2068

Universal Repair Seat

OD	ID	Thickness	Jobber	Order No.
28mm	20mm	8.0mm	\$5.99	MVS-14
29mm	21mm	8.5mm	5.99	MVS-18
30mm	22mm	8.5mm	5.99	MVS-22
31mm	23mm	8.5mm	5.99	MVS-26
1.255"	.750"	.437"	5.99	MVS-30
32mm	24mm	8.5mm	5.99	MVS-34
33mm	25mm	8.5mm	5.99	MVS-38
34mm	26mm	8.5mm	5.99	MVS-42
1.381"	.875"	.437"	5.99	MVS-46
1.505"	1.060"	.375"	5.99	MVS-50
1.630"	1.180"	.385"	5.99	MVS-54
1.692"	1.315"	.375"	5.99	MVS-58
1.820"	1.375"	.450"	6.99	HVS-1820
1.880"	1.435"	.410"	6.99	HVS-1880
1.945"	1.375"	.440"	6.99	HVS-1945
2.257"	1.550"	.500"	6.99	HVS-2257

AV&V Seal Drivers for Viton Valve Seals

- A must-have tool for installing valve seals
- Use with our .421" and .531" Viton Valve Seals

Seal Size	Order No.
4.5mm	VSD-45MM
5.0mm	VSD-5MM
5.5mm	VSD-55MM
6.0mm	VSD-6MM
7.0mm	VSD-7MM
5/16	VSD-312

Jobber \$22.99



Valve Seal Drivers

- For Harley-Davidson® OE-Style Seals
- Color coded for easy identification by size

Color	Size	Applications	Jobber	Order No.
Red	.420"	Fits HSS-420	\$4.99	VSD-R
Black	.530"/.562"	Fits HSS-530312, HSS-530341, HSS-562	4.99	VSD-B
White	.625"	Fits HSS-625	4.99	VSD-W

**Full Service
... FAST!!**



"Our job is to take your order correctly, confirm that the products are in stock and then get the order to shipping right away so that it's shipped the same day."

- Greg, Goodson Sales Associate, 7 years of service

Manganese-Bronze Valve Guides

Specifically for Harley-Davidson® heads



- Special high-temp Viton O-ring seal • Seal prevents oil from passing between the guide and the head • Smooth lead-in section for best alignment during installation • CNC machined to exact specifications for each application • Smooth finish prevents damage to ID of receiver holes • Chamfered IDs prevents oil from being scraped away at every stroke of the valve • Guide ID is unfinished and ready to be precision reamed or honed

High Performance Evolution, Twin Cam & Sportster

- Use with .421" Viton valve seals (HVS-421 or HSS-420) • Shorter for high lift & high flow applications

Size	OD	ID	Intake	Exhaust
Std.	.5625"	.3090"	HVG-5600S	HVG-5700S
.001"	.5635"	.3090"	HVG-5601S	HVG-5701S



Jobber \$9.49

Guide Driver for Reduced Diameter Top Valve Guides

We've developed this guide driver specifically for our NEW reduced diameter top valve guides (at left). The unique design eliminates mushrooming. The guide top fits into the groove between the driver and the bushing to both center the guide and drive it into place by putting pressure on the step top of the guide, not the seal area. You MUST use this driver to install these guides.

Order No. **VGD-315420** Jobber \$42.99



High Performance Evolution, Twin Cam & Sportster

- Use with .531" Viton valve seals (HVS-531) • Shorter for high lift & high flow applications

Size	OD	ID	Intake	Exhaust
Std.	.5625"	.3090"	HVG-5600	HVG-5700
.001"	.5635"	.3090"	HVG-5601	HVG-5701
.002"	.5645"	.3090"	HVG-5602	HVG-5702
.003"	.5655"	.3090"	HVG-5603	HVG-5703
.004"	.5665"	.3090"	HVG-5604	HVG-5704
.025"	.5875"	.3090"	HVG-5625	HVG-5725



Jobber \$9.49

Additional sizes are available for most guides. Call 1-800-533-8010 for information.

Evolution & Twin Cam

- Stock length for replacement
- Use with .530" OE-style valve seals (HSS-530312)
- Same guide fits Intake or Exhaust

Size	OD	ID	Order No.
Std.	.5625"	.3090"	HVG-5500
.001"	.5635"	.3090"	HVG-5501
.002"	.5645"	.3090"	HVG-5502
.003"	.5655"	.3090"	HVG-5503
.004"	.5665"	.3090"	HVG-5504
.015"	.5775"	.3090"	HVG-5515
.025"	.5875"	.3090"	HVG-5525



Jobber \$9.49

Shovel Head 1340cc (1979 - 1984)

- Use with OE-style valve seals (HSS-625) • Same guide fits Intake or Exhaust

Size	OD	ID	Order No.
Std.	.625"	.375"	HVG-5400
.001"	.626"	.375"	HVG-5401
.002"	.627"	.375"	HVG-5402
.003"	.628"	.375"	HVG-5403
.004"	.629"	.375"	HVG-5404
.006"	.631"	.375"	HVG-5406
.025"	.650"	.375"	HVG-5425



Jobber \$9.49

Fits 2005 & up High Performance 7mm Twin Cam, Sportster & Buell

- Use with stock style seals or HV-7MM for double spring application
- Tapered and shorter nose for high performance application

Size	OD	ID	Intake	Exhaust
Std.	.5625"	.273"	HVG-6600	HVG-6700
.001"	.5635"	.273"	HVG-6601	HVG-6701
.002"	.5645"	.273"	HVG-6602	HVG-6702



Jobber \$9.49

Shovel & Pan Head 1200cc (1948-1979)

- Use with OE-style valve seals (HSS-562)
- Same guide fits Intake or Exhaust

Size	OD	ID	Order No.
Std.	.566"	.375"	HVG-5300
.001"	.567"	.375"	HVG-5301
.002"	.568"	.375"	HVG-5302
.003"	.569"	.375"	HVG-5303
.004"	.570"	.375"	HVG-5304
.006"	.572"	.375"	HVG-5306
.008"	.574"	.375"	HVG-5308
.010"	.576"	.375"	HVG-5310
.025"	.591"	.375"	HVG-5325



Jobber \$9.49

XL 1957 to early 1983

Cast Iron

- Intake ID = .309"
- Use with OE-style valve seal (HSS-530312)
- Exhaust ID = .339"
- Use with OE-style valve seal (HSS-530341)

Size	OD	Intake	Exhaust
Std.	.5645"	HVG-5100C	HVG-5200C
.001"	.5655"	HVG-5101C	HVG-5201C
.002"	.5665"	HVG-5102C	HVG-5202C
.003"	.5675"	HVG-5103C	HVG-5203C



Jobber \$9.49

High Performance Edelbrock® & TP

- Use with .531" Viton valve seals (HVS-531)

Size	OD	ID	Intake	Exhaust
Std.	.5625"	.3090"	HVG-5600E	HVG-5700E
.001"	.5635"	.3090"	HVG-5601E	HVG-5701E
.002"	.5645"	.3090"	HVG-5602E	HVG-5702E
.025"	.5875"	.3090"	HVG-5625E	HVG-5725E



Jobber \$9.49

V-Rod

- Use with HVS-6mm valve seals

Size	OD	ID	Order No.
Std.	10.03mm	6mm	HVG-7000
.001"	10.07mm	6mm	HVG-7001



Jobber \$9.49

Universal Repair Guides

- Manganese Bronze
- Ready to be custom machined

Size	OD	ID	Length	Order No.
7mm	.740"	7mm	2.70"	UVBG-7MM
.313"	.740"	.308"	2.70"	UVBG-308
.375"	.740"	.372"	2.70"	UVBG-372



Jobber \$9.49

CYLINDER HEAD REBUILDING
CLEANING, ASSEMBLY & SAFETY
SHORT BLOCK REBUILDING
CRANKSHAFT/ FLYWHEEL GRINDING
BRAKE & ALIGNMENT TOOLS
MEASURING TOOLS
OFFROAD BIKE, ATV HARD PARTS
V-TWIN HARD PARTS



High Performance Valves

More applications online



Black Tulip® and Chrome Tulip Valves for Harley-Davidson® Engines

These superb valves feature the highest flow levels on the market. They are one piece forged from a racing grade stainless steel alloy and are available in hard black or chrome finish. Each valve has a bearing-quality hardened tip at the end of the stem to prevent premature wear with high-lift applications.

Application	Type	Head Dia.	OAL	Stem Dia.	Jobber	Black Tulip®	Jobber	Chrome Tulip
Evo Big Twin & Twin Cam 5/8" Valves	Exhaust	1.570"	4.525"	0.3106"	\$19.99	HBV-1570	—	—
	Exhaust	1.610"	4.525"	0.3106"	19.99	HBV-1610D	\$19.99	HCV-1610DC
	Exhaust	1.700"	4.470"	0.3106"	23.99	HBV-1700	—	—
	Exhaust	1.700"	4.535"	0.3106"	23.99	HBV-1700A	—	—
	Intake	1.900"	4.440"	0.3108"	19.99	HBV-1900	19.99	HCV-1900C
	Intake	1.940"	4.440"	0.3108"	19.99	HBV-1940	19.99	HCV-1940C
	Intake	1.990"	4.440"	0.3108"	23.99	HBV-1990	—	—
	Intake	2.020"	4.440"	0.3108"	23.99	HBV-2020A	—	—
	Intake	2.020"	4.490"	0.3108"	23.99	HBV-2020	—	—
	Intake	2.060"	4.480"	0.3108"	23.99	HBV-2060S	—	—
	7mm Twin Cam, Sportster, Buell Triple & Single Groove Valves	Exhaust	1.575"	4.545"	0.2755"	\$19.99	HBV-1575-7TG	\$19.99
Exhaust		1.610"	4.545"	0.2755"	19.99	HBV-1610-7TG	19.99	HCV-1610-7TG
Intake		1.810"	4.455"	0.2755"	19.99	HBV-1810-7TG	19.99	HCV-1810-7TG
Intake		1.810"	4.440"	0.2757"	23.99	HBV-1812-7TG	19.99	HCV-1812-7TG
Intake		1.850"	4.455"	0.2757"	23.99	HBV-1850-7TG	19.99	HCV-1850-7TG
Intake		1.900"	4.455"	0.2757"	19.99	HBV-1900-7TG	19.99	HCV-1900-7TG
Intake		1.980"	4.455"	0.2757"	23.99	HBV-1980-7TG	—	—
Exhaust		1.610"	4.545"	0.2755"	—	—	19.99	HCV-1610-7
Intake		1.900"	4.455"	0.2757"	—	—	19.99	HCV-1900-7
Sportster 883 to 1200 Conversion	Exhaust	1.480"	4.640"	0.3106"	\$19.99	HBV-1480**	—	—
	Intake	1.720"	4.560"	0.3108"	19.99	HBV-1720**	—	—
Sportster 1200 & Buell XB9 /XB12	Exhaust	1.575"	4.620"	7.0mm	19.99	HBV-1576-7TG	—	—
	Intake	1.770"	4.480"	0.3106"	19.99	HBV-1770	—	—
	Intake	1.810"	4.480"	7.0mm	19.99	HBV-1811-7TG	—	—
	Intake	1.851"	4.520"	7.0mm	19.99	HBV-1851-7TG	—	—
	Exhaust	1.580"	4.575"	0.3106"	—	—	\$19.99	HCV-1580
S&S®, Screaming Eagle® & Ultima® Heads	Intake	1.812"	4.486"	0.3106"	—	—	23.99	HCV-1813
	Exhaust	1.610"	4.565"	0.3106"	\$23.99	HBV-1610S	—	—
	Exhaust	1.700"	4.635"	0.3106"	23.99	HBV-1700U	—	—
	Intake	2.020"	4.480"	0.3108"	23.99	HBV-2020S	—	—
	Intake	2.060"	4.510"	0.3108"	—	—	\$23.99	HCV-2060LC
SE® / JIMS® 120 cu. in. Heads	Intake	2.100"	4.590"	0.3108"	23.99	HBV-2100U	—	—
	Exhaust	1.650"	4.510"	0.3106"	\$23.99	HBV-1650	—	—
	Intake	2.100"	4.475"	0.3108"	23.99	HBV-2100	—	—
Intake	2.150"	4.480"	0.3108"	—	—	23.99	HCV-2150	

Extreme Duty High Flow Replacement Valves (stock length and head diameter)

Application	Type	Head Dia.	OAL	Stem Dia.	Jobber	Black Tulip®
Sportster 833 (1986-2003)	Exhaust	1.355"	4.635"	0.3106"	\$19.99	HEV-1355
Sportster 833 (1986-2003)	Intake	1.590"	4.550"	0.3108"	19.99	HEV-1590
Sportster 900-1000	Exhaust	1.562"	3.510"	0.3389"	19.99	HEV-3
Sportster 900	Intake	1.812"	3.570"	0.3108"	19.99	HEV-4
Sportster 1000 (1970-1984)	Intake	1.940"	3.600"	0.3109"	19.99	HEV-5
Sportster 1200 (1987-2003)	Exhaust	1.485"	4.560"	0.3106"	19.99	HEV-1485
Sportster 1200 (1987-2003)	Intake	1.720"	4.480"	0.3108"	19.99	HEV-1720
Pan Head (1948-1965)	Intake/Exhaust	1.750"	3.825"	0.3765"	19.99	HEV-7
Shovel Head (1966-1984)	Intake	1.955"	3.875"	0.3770"	19.99	HEV-9
Shovel Head (1966-1984)	Exhaust	1.750"	3.825"	0.3765"	19.99	HEV-7
Evo 1340 (1984 & up)	Exhaust	1.615"	4.525"	0.3106"	19.99	HEV-10
Evo 1340 & Twin Cam (1984 & up)	Intake	1.845"	4.458"	0.3108"	19.99	HEV-11
Twin Cam (1999-2004)	Exhaust	1.570"	4.525"	0.3106"	19.99	HEV-12



Always check and confirm running clearances when installing new valves

Triple Groove Valves have 7TG at the end of the order number and Single Groove Valves have 7SG at the end of the order number.

*Oversize, all others are stock length and head diameter **Additional machining required

from one to one thousand ... no minimum orders required

REBUILDING

CLEANING, & SAFETY

SHORT BLOCK REBUILDING

FLYWHEEL GRINDING

CRANKSHAFT/ TOOLS

MEASURING TOOLS

OFFROAD BIKE, ATV HARD PARTS

V-TWIN HARD PARTS

Full Service
...FAST!!



"In addition to the wide selection of tools and supplies found in this catalog, we have access to hundreds of hard-to-find tools not shown due to their specialized nature. If you're looking for a special tool, call us and we'll help you find it."
- Darcie, Goodson Inventory Control, 4 years of service



Evo & Twin Cam Valve Spring Shims

- Two thicknesses to choose from
- OD: 1.480" • ID: 0.600"
- 20 per package

Thickness	Jobber	Order No.
0.15"	\$9.99	HVS-5015
0.30"	9.99	HVS-5030

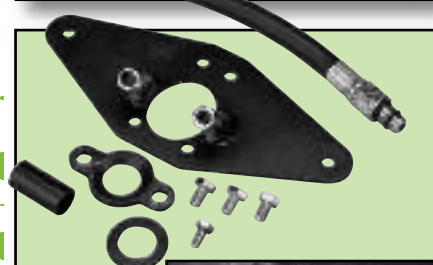

On-the-Engine Valve Spring Compressor

Replace broken valve springs, install high performance valve springs, remove and replace valve guide seals all without disassembling the bike – just remove the gas tank and get to work. Use on Sportster, Evolution, Twin-Cam and most aftermarket V-Twins. Kit includes valve spring compressor, adaptor for compressing beehive springs, valve seal driver/installer and head pressurizing hose.
Order No. **CF-HDIF** Jobber \$279.99

Evolution, Twin Cam & Sportster

High Performance Valve Spring Kits for 5/16" valves

- Ultra pure chrome silicon and nickel spring wire
- Extra processing for fatigue resistance
- 1.375" top retainers for better clearance inside rocker covers • Springs feature chamfered tops to match with smaller retainers
- Complete kit includes 4 springs, retainers, keepers and lower collars

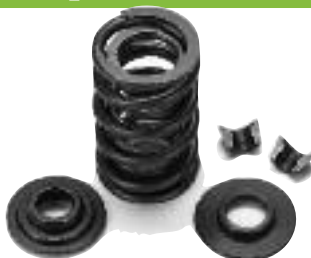

Max. Lift	Seat Pressure	Coil Bind Height	Spring Kit		10° Keepers (4pr)	
			Jobber	Order No.	Jobber	Order No.
Titanium Retainers						
.600"	*155#@1.875"/405#@1.260"	1.080"	\$139.99	HVS-600T	\$13.49	HVK-311A-4
.650"	185#@1.860"/460#@1.160"	1.080"	159.99	HVS-650T	13.49	HVK-311A-4
Steel Retainers						
.600"	*155#@1.875"/405#@1.260"	1.080"	\$77.99	HVS-600S	\$13.49	HVK-311A-4
.650"	185#@1.860"/460#@1.160"	1.080"	89.99	HVS-650S	13.49	HVK-311A-4

*Use Shims to change seat pressure to 175#@1.815"

Extreme Duty Valve Spring Kit for 5/16" valves

- Specially designed and processed with extra shot peening and nitrided to resist failure under the most extreme conditions when using serious high performance cams such as Bobby Woods
- Recommended for .640" to .675" lift
- Complete kit includes 4 springs, retainers, keepers and lower collars



Max. Lift	Seat Pressure	Coil Bind Height	Spring Kit		10° Keepers (4pr)	
			Jobber	Order No.	Jobber	Order No.
Titanium Retainers						
.675"	185#@1.860"/460#@1.160"	1.080"	\$199.99	HVS-675T	\$13.49	HVK-311A-4

Pan & Shovel Head

High Performance Spring Kits

- Silicon and vanadium alloy spring wire
- Increased travel before coil bind
- Complete kit includes 4 springs, retainers, keepers and lower collars



Max. Lift	Seat Pressure	Coil Bind Height	Spring Kit Order No.	9° Keepers (4pr) Order No.	Springs Only (4) Order No.	Upper Retainers Order No.	Lower Collars Order No.
.470"	155#@1.375"/300#@0.980"	0.850"	HVS-470S	HVK-375-4	HVS-470-4	HVR-530	HHC-4
.530"	155#@1.455"/320#@0.980"	0.850"	HVS-530S	HVK-375-4	HVS-530-4	HVR-530	HHC-4
.590"	175#@1.455"/350#@0.980"	0.850"	HVS-590S	HVK-375-4	HVS-590-4	HVR-530	HHC-4
	Jobber		\$78.99	\$13.49	\$49.99	\$29.99	\$29.99

*Note: These Pan/Shovel valve springs are not bold-in items. Always make sure to check the minimum spring spacing and to keep a minimum of .060" before coil bind, at full lift.

Early 1948-1980 heads must be machined to accept AV&V's late style lower collars.

You may need to machine the spring seat with Goodson spring seat cutter #VSS-1680HD and/or us AV&V upper spring collar kit HVR-530 and/or machine the valve seats deeper to get the correct spring spacing.

For reference on late style Shovel (1980-1984), with a 1.630" valve stem protrusion, the spring spacing is +/-1.375".



CYLINDER HEAD REBUILDING
CLEANING, ASSEMBLY & SAFETY
SHORT BLOCK REBUILDING
CRANKSHAFT/ FLYWHEEL GRINDING
BRAKE & ALIGNMENT TOOLS
MEASURING TOOLS
OFFROAD BIKE, ATV HARD PARTS
V-TWIN HARD PARTS

Replacement Valve Springs

Evolution, Twin Cam & Sportster

High Performance

Beehive Valve Spring Kits for 5/16" Valves

- Ultra pure chrome silicon and nickel spring wire
- Extra processing for fatigue resistance
- Resist pressure loss and failure associated with extremely aggressive cams in high compression engines • Reduce vibration and harmonics • Complete kit includes 4 springs, retainers, keepers and lower collars



7mm Chromoly Single Groove Retainer & Keeper Kits

- Use with Single Groove Valves or Triple Groove and OE Beehive Springs • Oversized 7° keepers are designed to be stronger than OE keepers • 4 Pc. Set
- Order No. **HVR-7MM-SG** Jobber \$34.79



Max. Lift	Seat Pressure	Coil Bind Height	Spring Kit		9° Keepers (4pr)	
			Jobber	Order No.	Jobber	Order No.
Steel Retainers						
.600"	165#@1.860"/384#@1.250"	1.200"	\$89.99	HVS-6000S	\$13.49	HVK-311C-4
.650"	180#@1.880"/385#@1.200"	1.150"	89.99	HVS-6500S	13.49	HVK-311C-4

NOTE: .600" Lift Springs – Small end ID: .650", OD: 1.085" / Large end ID: 1.000", OD: 1.445"
 .650" Lift Springs – Small end ID: .740", OD: 1.185" / Large end ID: 1.055", OD: 1.500"



Beehive Valve Spring Kits for 7mm Valves

- Ultra pure chrome silicon and nickel spring wire
- Extra processing for fatigue resistance
- Resist pressure loss and failure associated with extremely aggressive cams in high compression engines • Reduce vibration and harmonics • Complete kit includes 4 springs, retainers, keepers and lower collars

HVS-6000-7SG



HVS-6500-7SG



Max. Lift	Seat Pressure	Coil Bind Height	Spring Kit		9° Keepers (4pr)		Seals	
			Jobber	Order No.	Jobber	Order No.	Jobber	Order No.
Single & Triple Groove								
.600"	165#@1.860"/384#@1.250"	1.200"	\$77.99	HVS-6000-7SG	\$13.49	HVK-7MMMSG-4	\$28.99	HV-7MMOE
.650"	178#@1.860"/385#@1.200"	1.150"	89.99	*HVS-6500-7SG	13.99	HVK-7MMMSGC-4	28.99	HV-7MM

NOTE: .600" Lift Springs – Small end ID: .650", OD: 1.085" / Large end ID: 1.000", OD: 1.445"
 .650" Lift Springs – Small end ID: .740", OD: 1.185" / Large end ID: 1.055", OD: 1.500"

*Due to their larger size, HVS-6500-7SG Springs come with their own lower collars and must be used with HV-7MM valve seals.

Beehive Valve Spring Kits for V-Rod

- Ultra pure chrome silicon and nickel spring wire
- Extra processing for fatigue resistance
- Resist pressure loss and failure associated with extremely aggressive cams in high compression engines • Reduce vibration and harmonics • Complete kit includes 8 springs, steel retainers, and 16 triple groove or single groove keepers • Use with stock lower collars



To achieve the best results, always use components from the same manufacturer. You'll be amazed at the difference!

Max. Lift	Seat Pressure	Coil Bind Height	Single Groove (8 springs)		Triple Groove (8 springs)		Seals	
			Jobber	Order No.	Jobber	Order No.	Jobber	Order No.
Triple Groove								
.580"	83#@1.500"/280#@0.900"	0.870"	\$159.99	HVS-7000SG	\$159.99	HVS-7000TG	\$18.99	HVS-6MM

NOTE: .600" Lift Springs – Small end ID: 0.574", OD: 0.940" / Large end ID: 0.735", OD: 1.100"

CYLINDER HEAD REBUILDING

CLEANING, ASSEMBLY & SAFETY

SHORT BLOCK REBUILDING

CRANKSHAFT/ FLYWHEEL GRINDING

BRAKE & ALIGNMENT TOOLS

MEASURING TOOLS

OFFROAD BIKE, ATV HARD PARTS

V-TWIN HARD PARTS

Universal Repair Guides

- Ready to be machined on lathe as custom guide
- Unfinished ID ready to be reamed with AV&V's exclusive carbide reamers (right)
- Manganese bronze

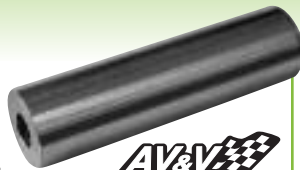

ID	OD	Length	Jobber	Order No.
4.5mm	.620	2.000"	\$7.49	UVBG-4.5MM
5.0mm	.620	2.225"	7.49	UVBG-5MM
5.5mm	.620	2.375"	7.49	UVBG-5.5MM
6.0mm	.620	2.375"	7.49	UVBG-6MM
7.0mm	.740"	2.700"	9.49	UVBG-7MM
.308"	.740"	2.700"	8.99	UVBG-308
.372"	.740"	2.700"	8.99	UVBG-372
.341"	.740"	2.700"	8.99	UVBG-341



Solid Carbide Valve Guide Reamers Specifically designed for use with bronze guides only

- Features a longer pilot and multi-fluted design so you can size guides perfectly
- One size allows you to fit both intake & exhaust when using AV&V valves and guides
- 300 to 400 RPM is recommended
- Should take 3-5 seconds to ream one guide
- Use with Bronze Reaming Oil (**BW-303A-G**) on page 73
- **DO NOT** use on cast iron

.421" Valve Seal Cutter

- Evo/Twin Cam
- Will shorten and chamfer the guide top, increasing seal-to-retainer clearance for higher lift camshafts
- Can also be used to modify .530" guides to .421" guides
- Chuck into any portable drill, drill press or seat and guide machine
- Guide OD: .421" (10.7mm)
- Pilot Size: .312" (7.9mm)
- Use **HVS-421** seal (page 129)
- Order No. **VSC-420312** Jobber \$79.99



Pan/Shovel Spring Seat Cutting Tool

- Convert Pan & early Shovels to late style Shovel easily
- Allows higher lift on Panheads and early Shovel Heads
- Included spacer stops the cutter at the correct height for uniform spring spacing
- Use with lower spring collars (**HHC-4**) or stock late-style lower spring collars (1980-1984)



Description	OD	ID	Jobber	Order No.
Spring Seat Cutting Tool	1.680"	0.750"	\$74.99	VSS-1680HD
.375" Spring Pad Pilot			19.99	VP-375

Dia.	Jobber	Order No.	Dia.	Jobber	Order No.
4.0mm	\$177.99	HGR-4.0MM	.3160"	\$224.99	HGR-3160
4.5mm	177.99	HGR-4.5MM	.3410"	224.99	HGR-3410
5.0mm	177.99	HGR-5.0MM	.3420"	224.99	HGR-3420
5.5mm	179.99	HGR-5.5MM	.3425"	224.99	HGR-3425
6.0mm	209.99	HGR-6MM	.3430"	224.99	HGR-3430
6.5mm	209.99	HGR-6.5MM	.3435"	224.99	HGR-3435
6.6mm	209.99	HGR-6.6MM	.3440"	224.99	HGR-3440
7.0mm	224.99	HGR-7MM	.3450"	224.99	HGR-3450
.2766"	219.99	HGR-2766	.3540"	224.99	HGR-3540
.3110"	219.99	HGR-3110	.3720"	224.99	HGR-3720
.3115"	219.99	HGR-3115	.3730"	224.99	HGR-3730
.3120"	219.99	HGR-3120	.3740"	224.99	HGR-3740
.3130"	224.99	HGR-3130	.3750"	224.99	HGR-3750
.3140"	224.99	HGR-3140	.3777"	219.99	HGR-3777
8.0mm	224.99	HGR-8MM	.3782"	219.99	HGR-3782

Due to the characteristics of carbide, we can only guarantee the reamer's dimensional accuracy.



Compression Release Valves

- Shorter thread sections on **HDCR-10S** and **HDCR-10L** makes installation easier with less drilling required than OE-style
- High temperature resistant knobs
- 2 per pack
- 10 x 1.0mm thread

Application	Length	Thread	Jobber	Order No.
Evolution	1.080"	.425"L	\$49.99	HDCR-10S
Twin Cam	1.740"	.425"L	49.99	HDCR-10L
OE Replacement	1.250"	.475"L	49.99	HDCR-10D

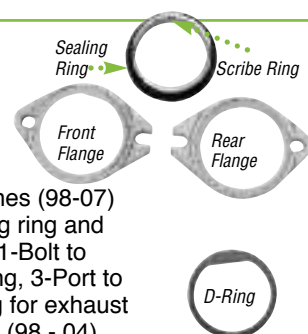

Intake Scribe Ring Kit

- For porting Evo & V-Twin engines (98-07)
- Kit includes 2 flanges, 1 sealing ring and 1 scribe ring
- Easy as 1-2-3
- 1-Bolt to intake port, 2-Scribe around ring, 3-Port to scribe marks
- Optional D-Ring for exhaust port scribing on Evo & V-Twins (98 - 04)

Description	Jobber	Order No.
Intake Scribe Ring Kit	\$66.99	HSR-1650KIT
D-Ring for Exhaust Port Scribing	20.99	HSR-1625D

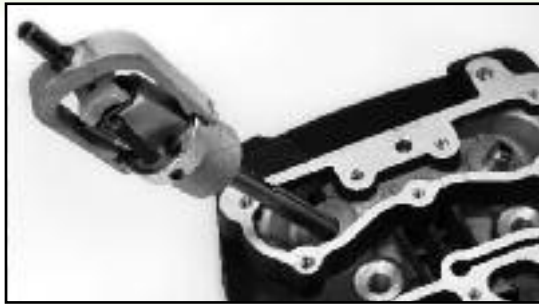

Valve Guide Hone Tooling for Harley-Davidson® Cylinder Heads

- Produces straight, round holes for top-quality work • Ideal for high-performance applications
- Use a low RPM, 1/2" drill for driving power (200 RPM max.) • Use with your **P-180** Honall® Driver • Use with Rod Honing Oil (**RHO-50**) on page 73
- Only one head and driver is required • Mandrels are available to cover all popular models

Description		Jobber	Order No.						
Sunnén Honall® Valve Guide Hone Head & Driver		\$286.49	P-180						
		Mandrel		Truing Sleeve		Stones		Adaptor	
Application: All EVO, Pan/Early Shovel, XR-750/1000, XL-Sportser®, 45" (1143mm) Flat Head and 74-80" (1879-2032mm) Flat Head									
Nominal Size	Range	Jobber	Order No.	Jobber	Order No.	Jobber	Order No.	Jobber	Order No.
3/16"	.557" - .588"	14.1-14.9mm	\$54.49 BL16-557AS	\$13.49 S-557	\$42.99 L16-J47 (6)	\$61.79 PK16-A			
Application: Late Shovel and Knuckle Heads									
Nominal Size	Range	Jobber	Order No.	Jobber	Order No.	Jobber	Order No.	Jobber	Order No.
5/16"	.619" - .650"	15.7-16.5mm	\$58.49 BL20-619AS	\$15.49 S-619	\$41.99 L20-J67 (6)	\$59.99 PAK20-A			

See pages 25 for additional sizes of valve guide hone tooling • Oversize Guides on page 27



Small OHV Engine Keeper Removal/Installation Tool

- Easy to use
- Uses your own body weight as leverage to remove or install keepers
- Works with 3.5mm to 5.5mm single groove valves only
- Complete set includes a remover with powerful magnet to hold the keepers in place after removal, universal installer to fit valve stems from 3.5 to 5.5mm and two non-slip valve chamber pads
- Order No. **VKI-35** Jobber \$99.99

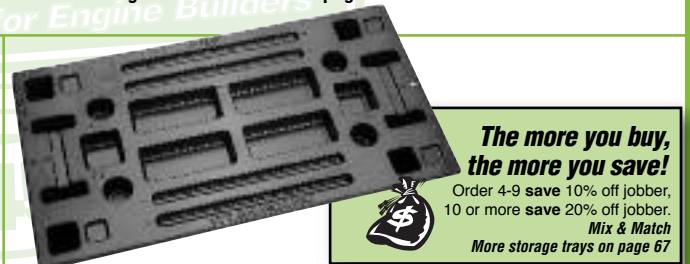

Harley® Head Organizer Tray

- Now that you have the head apart, keep it organized and protected • Virtually unbreakable molded plastic • Oil and solvent resistant • Trays stack for easy storage
- Dimensional weight applies
- Order No. **HHO-2** Jobber \$44.99

The more you buy, the more you save!
 Order 4-9 save 10% off jobber, 10 or more save 20% off jobber.
 Mix & Match
 More storage trays on page 67

T6 Aluminum Torque Plates

- Fit most OE Harley-Davidson® engines
- Two sizes to choose from
- Includes top and base plates and mounting hardware

Application	Jobber	Order No.
Evolution & Shovel	\$499.99	HHD-SEV
Twin Cam / V-Rod	479.99	HHD-2CAM

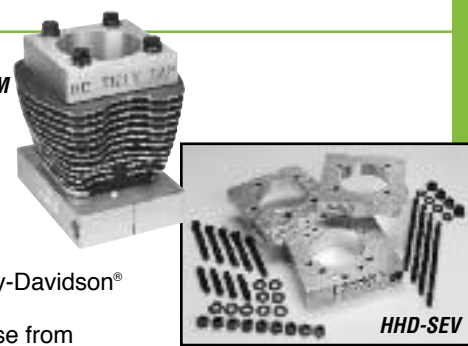

CYLINDER HEAD REBUILDING
 CLEANING, ASSEMBLY & SAFETY
 SHORT BLOCK REBUILDING
 CRANKSHAFT/FLYWHEEL GRINDING
 BRAKE & ALIGNMENT TOOLS
 MEASURING TOOLS
 OFFROAD BIKE, ATV HARD PARTS
 V-TWIN HARD PARTS

RAPIDEX

A rapid-use index of **product categories**

Cylinder Head Rebuilding

Valve Seat Work.....	2-21
Pilots	2-3
Valve Refacing	20-21
Reamers.....	22-23
Valve Guide Resizing	24-25
Valve Guide Replacement.....	26-31
Valve Seal Work.....	32-33
Valve Spring Work.....	34-40
Cylinder Head Resurfacing	41-44
Crack Detection & Repair.....	45-51
Porting & Polishing.....	56-59
Valve Adjustment Discs	55

Cleaning, Assembly & Safety

Cleaning.....	60-65
Wire Wheels & Brushes	60-61
Parts Baskets	66
Parts Storage & Organizers	66-68
Last Blast Paint	69

Flex-Hones®.....	72
------------------	----

Index

..... Falls between pages 72 & 73

Coolants & Lubricants	73
-----------------------------	----

Short Block Rebuilding

Cylinder Boring & Honing	70-93
Boring Bar Tooling & Supplies.....	70
Honing Stones.....	75-79
Rod Honing	80-81
Rod & Piston Work.....	83-88
Cylinder Block Work.....	89-92
Camshaft Work.....	93-94

Crankshaft/Flywheel Grinding

Crankshaft Grinding Wheels	95-97
Crankshaft Grinding & Polishing	98-102
Flywheel Grinding	103-105

Miscellaneous Tools

Diamond Dresser Tools.....	106-107
Technical Manuals & Videos.....	110
Machine Replacement Parts	109

Brake & Alignment Tools

Brake Tips & Holders	111-112
Brake Lathe Silencers.....	113
Brake Lathe Replacement Parts.....	114-117
Brake Lathe Mounting Adaptors	118-119
Alignment, Tire Changing & Balancing.....	120

Measuring Tools

Calipers & Dial Indicators.....	122
Micrometers.....	123
Dial Bore Gauges.....	134-125

Offroad Hard Parts

Replacement Valves.....	126
Valve Guides	127
Valve Springs.....	128
Seals & Seat Inserts.....	129

V-Twin Hard Parts

Valve Guides	130
Replacement Valves.....	131
Valve Springs	132-133

© Copyright 2012, Goodson Mfg. Co., Inc. All copy and illustrations are copyrighted. Absolutely no mechanical or electronic reproduction or use of any part is allowed without our prior written permission. Goodson reserves the right to correct printing errors. Prices are subject to change without notice.

Exclusive



Plate swivels a full 45° either way and is lockable anywhere in between



Harley® Head Plate and Head Stand

- Fits Shovel, Evolution, Twin-Cam, V-Rod, Sportster and Pan heads
- Rigid enough for cutting and installing guides and seats
- Adjustable positive stops for leveling and machining
- Use on seat and guide machine and/or head resurfacer
- Includes 2 risers
- Instructions include easy-to-read diagrams for mounting Harley® heads
- Blackened steel

Description	Jobber	Order No.	Incl.
Complete Unit	\$739.99	HHS-600	▼
Head Stand	429.99	HHS-601	x
Head Plate	429.99	HHP-6	x



Exclusive

Double Harley Head Plate

This NEW Head Plate takes the universal design of our HHP-6 Head Plate one step further to accommodate two heads at the same time. Due to its unique mounting system, it fits Shovel, Evolution, Twin Cam, V-Rod, Sportster and Pan heads. The plate is heavy enough for cutting and installing guides and seats and is designed to be used on a seat and guide machine or Bridgeport-type Mill, including CNC machines. Mounting instructions (with diagrams) for all head types are included. Blackened steel construction.

NOTE: The HHP-26 does **not** include any fastener bolts for the cylinder heads. Order No. HHP-26 Jobber \$899.99

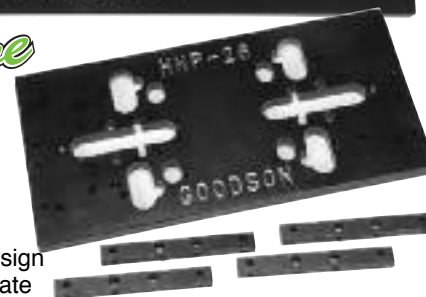

CYLINDER HEAD REBUILDING

CLEANING, ASSEMBLY & SAFETY

SHORT BLOCK REBUILDING

CRANKSHAFT/FLYWHEEL GRINDING

BRAKE & ALIGNMENT TOOLS

MEASURING TOOLS

OFFROAD BIKE, ATV HARD PARTS

V-TWIN HARD PARTS

Index

3-D Fast Cut™	
3-D Fast Cut™ Starter Kits	4
Ball Head Drive Adaptors	4
Bounce Springs	4
Bowl Profiler	6
Counterbore Cutters	5
Lift Clip	4, 6
Micro Ball Head Tooling	5
Pilots	2, 3
Setting Micrometer	5
Tool Setting Fixture	4
Universal Spring Pad Cutters	8
Valve Seat Cutter Blades	6, 7
Valve Seat Cutter Tool Holder	4, 5
Valve Seat Removal Tooling	5

A

Abrasive Belt Dresser	102
Abrasives	
Aluminum Oxide Cloth Shop Rolls	56
Bench Grinder Wheels	108
Cartridge Rolls	56
Cam Grinding Wheels	93
CBN Inserts	41
Chamfering Cones	38, 77
Crankshaft Grinding	95 - 97
Crankshaft Polishing Belts	100-102
Crocus Cloth	56
Cross Buffs®	56
Cylinder Head Resurfacing	41 - 44
Cylinder Honing	74 - 80
Diesel Super Abrasive Insert	41
Discs	56
Flex-Hones®	72, 117
Flywheel	104 - 105
Grinding Discs	56
Honing	74 - 80
Hyper-Finish Diamond Honing	24
Mounted Points	58
PCD	41
Rod & Cap Grinding Wheels	73
Rod Honing / Pin Fitting	80, 81
Sleeves	57, 116
Valve Refacing	20 - 21
Valve Seat	14 - 16
Air Tools	19, 26, 108
Align Honing	79
Alumni-Chek	49
Ammco	
Brake Lathe Arbors	114
Brake Lathe Cutting Tips	111
Honing Stone Sets	77
Replacement Parts	114 - 116
Aprons	63
Assembly Lube	89, 90
AV&V Brand Hard Parts	33, 126 - 134
B	
Bags	42, 68
Balance Shaft Eliminator Kits	51
Balancing Scales	99
Ball Broaches	29
Ball Hones	72, 117
Baskets	66
Beehive Springs	133
Belt Dressers	104
Belts	
Black & Decker Valve Refacer Belt	109
Crankshaft Polishing	100, 101
Cylinder Head Resurfacing	43
Kwik-Way Valve Grinder Belts	109
Rod Honing Belts (for Sunnen)	80
Sioux Replacement Belts	109
Sunnen® Honing Machine Belts	109
Bench Grinder Wheels	108
Bit Sharpener	9
Black & Decker	
Adaptor for Sioux Stones	18
Belts for Valve Refacer	109
Gruv-Top Pilots & Collets	3
Replacement Collet	21
Stone Holders & Accessories	18
Valve Refacer Wheels	20
Valve Seat Stones	16
Black Lights	49
Blood Friction Master®	89
Bluing Fluid	8, 13
Bore Gauges and Stand	124, 125
Boring Bar Cutters & Accessories	70
Bounce Springs	4, 5, 18
Bousfield Valve Tool Cutters	9
Bowl Profiler Tooling & Blades	8
Brake Fluid Test Strips	117
Brake Lathe Arbors	114
Brake Lathe Cutting Tips	111
Brake Lathe Replacement Parts	113 - 117
Brake Lathe Silencer Bands	113
Brake Lathe Tip Holders	112
Brake Lubes	119
Break-In Lubes	89, 90
Bronze Liners & Tooling	28, 29
Bronze Reaming Oil	23, 30, 73
Bronze-Wall®, Bronze-Wall 2®	30
Brushes	60, 61
Burets and Stands	40
Burr Buster	108
Burrs	58, 59
C	
CamShield®	90
Calipers	122
Camshaft Work	
Cam Bearing Tools	93, 94
Cam Bore Washing Brushes	60, 93
Cam Wheels	93
Carbide	
Ball Broaches	29
Brake Tips	111
Burrs	59, 59
Pilots	2, 3
Reamers	23, 134
Resurfacing Tips	43
Rotary Files	59
Sizing Balls	29
Spot Facers / Top Cutters	31
Cartridge Rolls	56
CBN Cutter Inserts	41
CBN Flywheel Stones	104
CC-ing Equipment	40
Centering Cones, 60°	28
Ceramlub™	28
Chamfer Tool	72, 117
Chamfering Cones	38, 77, 135

Chevrolet	
Conversion Plate	52
Oil Dipstick Conversion	90
Small Block Chevy Deck Plug Kit	91
Starter Drill Jig	92
CLASSIC® Offset Keepers	37, 40
Cleaning Supplies	
Aprons	63
Brushes	60, 61
De-foaming Agent	65
Detergents	65
Glass Beads	63
Gloves	63, 66
Parts Tumbler Solution	63
Pro-Jet Spray Cleaner	65
Scrapers	81
Shop Towels	66
Sludge Filter Bag	64
Ultrasonic Detergents & Filters	65
Clover Lapping Compound	13
Collets	
Black & Decker	3, 21
Dowel Puller	91
Expanding Pilots	2
Concentricity Gauges	20
Connecting Rod Heaters	87, 88
Coolants, Lubricants & Oils	
Adjustable Coolant Hoses	64
All-Purpose Grinding Coolant	73
Belt Resurfacer Coolant	43, 73
Bronze Reaming Oil	23, 30, 73
Cosmoline®	64
Crank & Cam Grinding Coolant	73, 95
Cutting and Tapping Fluid	8, 73
Cylinder Honing Oil	73, 77
Diamond Honing Oil	24, 73
Extreme Pressure Lube	89
First Lube and Blood Friction Master®	89
Flywheel Grinding Coolant	73, 104
Flywheel Grinder Table Lubricant	73
Gasket Maker / Thread Sealer	69
High Performance Resurfacing Spray	41, 73
High Performance Valve Grinding Aid	20
Hylomar®	69
Knurlube	31
Lap Oil	56, 71, 73
Magna-Fluro Oil	49
Microbiostat	65
Minnesota Fast Freeze	9, 84
Multi-Duty Grinding Coolant	73
Porting & Polishing Machining Aid	56
Plate Lube	46
Press Fit Lubricant	26, 89
Pumps & Hoses	64
Rod Honing Oil	73, 80
Rust Inhibitor for Pressure Tester	51
Rust Proofing Oil	64
Rust Shield	42, 64, 73
Seat Cutting Fluid	8, 73
Spray Assembly Lube	55
Surface Grinding Coolant	44, 73
Tap Oil	51, 73
Universal Coolant Magnet	64
Universal Gel Lube	38, 55, 135
Valve Grinding Oil	20, 73
Valve Seat Machining Aid	9
Way Oil	73

Index

- Core Drills / Reamers**22
Cosmoline®64
Counterbore Cutter Drive Adaptors & Kit11
Counterbore Cutters5, 12
Cross-Buffs®56
Crack Detection and Repair
Additives50
Alumni-Chek49
Applicators48
Black Light Crack Detection Kit49
Engine Seal Tabs50
Fluid Weld®50
Goodson Glow49
Heat Tabs50
Magna-Fluro Oil49
Magnaflux®48
Magnaglo®49
Magnetic Field Indicator48
Parker Magnetic Crack Detection Unit47
Powder48, 49
Magnetic Crack Detection Kit47 - 49
Repair Kit51
Seal-All™50
Small Parts Demagnetizer48
Threaded Plugs51
Ultra-Violet Light Inspection Kit49
Crankshaft
Bearing Scraper94
Crank Grinding Coolant73, 95
Crank Grinding Wheels96, 97
Crank Welding Plugs102
Dial Indicator, Starrett99, 122
Diamond Dresser Tools95, 107
Display Inspection Stand100
Eliptibur Tool103
Grinding Coolant73, 95
Grinding Wheel Recycling95
Grinding Wheel Sizes96, 97
Hardness Tester98
Harmonic Dampener Installer103
Journal Radius Gauge99
Peening Tool98
Plastigage98
Polishing Accessories102
Polishing Belts100, 101
Polishers102
Polisher Motor102
Reluctor Ring Installation Tool103
Steady Rest Shoes99
Steel Stamps102
Stroke Checker98
Stroker Mimic™98
Crocus Cloth56
Cutting & Tapping Fluid8, 73
Cylinder Block Work
Automotive Dowel Puller & Collets91
Deck Bridge Combination Tool122
Frost Plug Tools92
Lifting Sling94
Oil Gallery Brushes60
Oil Gallery Plugs & Tools91
Pin Pal Puller91
Cylinder Head CC-ing Equipment40
Cylinder Head Resurfacing
Belt Resurfacer Coolant43, 73
CBN Cutter Inserts41
Dressers44
Cylinder Head Resurfacing (cont.)
Grind Aid42
PCD Inserts for Aluminum41
Rotary Broach Tool Bit43
Roughness Tester44
Segments42
Surfacing Belts43
Surfacing Wheels44
Cylinder Honing
Chamfering Cones and Mandrels77
Hone Stop Collar77
Honing Oil73, 77
Portable Cylinder Hones74
Small Diameter Honing Sets74
Stones74 - 79
Ammco77
Goodson75, 76
Keyway Honing Stones76
Lisle®74, 77
Sunn®74 - 79
D
D-Foam65
Dampener Installer103
Deburring Tools108
Deck Bridge Combination Tool122
Deck File71
Deck Plug Kit91
Degree Wheel94
Demagnetizer48
Depth Gauges104
Detergents65
Dial Indicators122
Dial Bore Gauge Setting Fixtures124, 125
Dial Bore Gauges124, 125
Dial Caliper Gauges124
Diamond Dresser Tools81, 106, 107
Diamond File Set86
Diamond Flex-Hones®72
Diamond Guide Hone Tools24
Diamond Honing Oil24, 73
Diamond Laps & Accessories71
Die Grinders57
Diesel
Core Reamers & Drills22
Heat Tabs50
Seat Installers22
Spring Compressor34
Super Abrasive41
Valve Guides27
Valve Guide Tooling22, 27
Valve Seals33
Wheel Dresser17
Disposable Assembly Wipes66
DOHC Organizer Tray67
DOHC Timing Chain Tightener71
Double Angle Valve Seat Wheels16
Dowel Puller & Collets91
Dressers
Abrasive Dresser102
CBN Dressing Stick104
Crankwheel Diamond Dressers95, 106, 107
Diamond Stone Dresser81
Flywheel Dressers104
Hand-Held Dressing Sticks95
Premium Diamond Dressers106, 107
Resurfacer Grinding Wheel Dresser44
Dressers (cont.)
Cutter Assemblies44, 104
Star Dressers44, 104
Valve Seat Wheel Stands17
Drill Bits, Left-Handed108
Drill Jig for Chevy Starter92
Drill-Ream, Oversize29
Drive Adaptors4, 11
DVDs110
Dykem®8, 13
E
Eliptibur Tool103
Engine Pre-Lube Supplies89, 90
Engine Balancing Supplies99
Engine Cart67
Engine Seal Tabs50
Epoxy, Porting57
Expanding Pilots2
Extreme Pressure Lube89
F
False Guides27, 134
Fast Freeze9, 84
Feeler Gauges55, 121
Fel-Pro Lapping Compound13
File71, 86
Filter Bag64
Filter Paper78
First Lube89
Flex-Hones®72, 117
Fluid Weld®50
Flywheel Grinding
Bolt Adaptors104
CBN Flywheel Stones & Dressing Stick104
Coolant73, 104
Cutter Tip104
Dowel Puller & Collets91
Depth Gauge104
Dressers104
Grinding Stones104, 105
Mounting Adaptor105
Radius Cutter Tip Holder104
Flywheel Saver Shims103
Flywheel Step Gauge104
Ford
Flywheel Saver Shims103
Torque Plates71
Frost Plug Tools92
G
Gasket Maker69
Gas Porting Tools85
Gel Lube38, 55
General Motors (GM)
Flywheel Saver Shims103
Vortec Adaptor Plate Set52
Vortec Seals32
Vortec Seal Cutter32
Vortec Spring Seat Cutter38
Glass Beading Supplies62
Gloves
Glass Bead62
Heat & Flame Resistant66
Hot Tank Gloves63
Nitrile66
Parts Washing Gloves66

Goodtool Brand (see page 7 of index)	
Grind Aid	42, 102
Grinding Stones & Wheels (see abrasives)	
Guide Knurling	
Knurling Arbors	31
Knurlube	31, 73
OD Knurling Tool	31
Speed Reducer	31
Guide Installers	26, 27
Guide Liners	29
Guide Tooling, Diesel	22
H	
Hardness Tester	98
Harley-Davidson® (see V-Twin)	
Harmonic Dampener Installer	103
Head Bolt Washer Remover	40
Head Bolt Spot Facer	53
Head Holders	59, 136
Head Saver Shims	52
Head Stands	59, 136
Head Straightening Fixture	54
Head Straightening Oven	54
Head-Bolt Hole Cleaner	51
Heat Tabs	50
Heavy Metal	99
Height Gauges	38
High Performance	
Cam Wheels	93
CC-ing Equipment	40
Gasket Maker & Thread Sealer	69
Porting & Polishing Machining Aid	56
Resurfacing Spray	41, 73
Valve Grinding Aid	20
Valve Seat Cutter Blades	6, 7
Valve Spring Compressors	34 - 37
Valve Spring Inserts	40
Valve Train Checking Springs	39
Hi-Temp Last Blast	69
Hone Plates	71
Hone Stop Assembly	77
Honing Oil	73, 77
Honing Stones	
Cylinder Honing	74 - 79
Pin Honing	81
Rod Honing	80, 81
Valve Guide	24, 25, 135
Hoses	64
Hot Tank Detergents	65
How-To Manuals & Videos	110
Hydraulic Sleeve Installer	82
Hydraulic Stud Puller	53
Hylomar® Gasket Maker & Solvent	69
Hyper Finish Diamond Guide Sizing	24
I	
ID Tags	68
IDL	
Core Drills & Reamers	22
Replacement Cutters	12
Valve Refacer Wheels	20
Indexable Counterbore Cutters	12
Indicators	122
Infinite Flow Cutting Tips (IFT)	6
Instructional Manuals & Videos	110
Internal Calipers	124
Iron-tite	50, 51

J	
Jet Spray Cleaner	65
Jet Valve Eliminator Kit	51
Jet Washer Parts Baskets	66
K	
Keepers, Classic	37, 40
Keeper-Keeper	36, 61
Keeper Tools	36, 135
Keyway Honing Stones	76
Knurling	31
KO Lee Valve Refacer Wheels	21
Kwik-Way	
Belts	109
Boring Bar Cutters	70
Core Drills & Reamers	31
Drive Adaptor	18, 19
Expanding Pilots	2
Rebuild Kit for KW Holder	18
Resurfacer Wheel Segments	42
Single-piece Resurfacer Wheels	44
Solid Tapered Pilots	3
Stone Holders	18
Valve Refacer Wheels	20
Valve Seat Stones	15, 16
L	
Lapping Oil	56, 71, 73
Lapping Tools & Compound	13
Last Blast Paint	69
Layout Fluid	8, 13
Leak-Down Tester	121
Left Hand Drill Bits	108
Letter Stamps	68, 102
Levels & Vials	41
Lifter Bore Tools	92
Lifting Sling	94
Lights	
Black Lights	49
Inspection Lights	110
LED Lights	110
Light Bulbs	49
Rough Service Fluorescent	110
Work Light	110, 114
Liners, Guide	29
Lisle® Honing Stone Sets	74, 77
Lubricants	
Blood Friction Master®	89
Brake Lubes	119
Break-In Lube	89
Cam-Shield® Assembly Lube	90
Extreme Pressure Lube	89
First Lube	89
Flywheel Grinder Table Lubricant	73
Way Oil	73
M	
Magnaflux®	
Field Indicator	48
Magna-Fluro Oil	49
Magnaflux® Powder	48
Magnaglo®	48
Y-7 Crack Detector	48
Mandrels	
Align Hone	79
Butterfly Mandrels	56

Mandrels (cont.)	
Cross Buff / Flap Wheel Mandrel	56
Diamond Sizing System	24
Honing	74, 79, 80
Rod Honing Mandrels	81
Roll Mandrels	56
Manual Ring Grinders	86
Manual Spring Compressors	35, 36, 37
Manual Valve Guide Drivers	26
Markers	68, 69
Measuring Tools	
Bore Gauges	124, 125
Calipers	122
Crankshaft Dial Indicator	99, 122
Dial Indicators	99, 122
Feeler Gauges	55, 121
Flywheel Depth Gauge	104
Leak Down Tester	121
Micrometers	123
Profilometer	44, 121
Push Rod Concentricity Checker	122
Rod Bolt Stretch Gauges	121
Rotor Micrometers	120
Setting Micrometer	5
Small Hole Gauge Set	29, 123
Straight Edges	54, 121
Stroke Checker	98
Surface Roughness Tester	44, 121
Telescoping Gauge Set	121
Valve Seat Run-Out Gauge	9, 123
Valve Stem Height Gauge	18, 122
Warp Alignment Gauge	54, 121
Metal Markers	69
Micrometers	123
Microbiostat	65
Minnesota Fast Freeze	9, 84
Mitutoyo®	
Calipers	122
Dial Bore Gauge	124
Micrometers	123
Split Ball Bore Gauge	123
Mondello Seat Cutter Blades	6
Motors	
Brake Lathe	114, 117
Crankshaft Polisher	102
Mounted Points	58
N	
Neway	
Valve Seat Cutters	10
Easy Turn Wrench	10
Pilots	2, 3
Replacement Cutter Blades and Screws	10
Solid Tapered Pilots	3
Nicasil Honing Stones	78
Number Stamps	68, 102
Nylon Brushes	60
O	
O-Ring Cutters & Accessories	71
O-Ring Wire	71
Offset Valve Keepers	37, 40
Off Road Motorcycle Parts	126 -129
Oil Dipstick Conversion Parts	90
Oil Filter Tools	90
Oil Gallery Brushes	60
Oil Gallery Tools	90, 91

Index

- Oil Gallery Wax**91
- Oil Pre-lube Tank**89
- Organizers**67
- Oven, Head Straightening**54
- Oversize Bronze-Liners**29
- Oversize Reamers**29
- Oversize Valve Guides**27, 127, 130
- Oversize Valve Seat Inserts**12, 129
- P**
- Paint**
 - Last Blast Spray Paint69
 - Markers69
- Parts Cleaning**
 - Baskets66
 - Brushes60, 61
 - Glass Bead Guns & Media62
 - Glass Bead Cabinet Window Film62
 - Gloves62, 63, 66
 - Hydro-Air Guns62
 - Keeper-Keeper36, 61
 - Parts Tumbler Solution63
 - Replacement Cartridge Filters65
 - Roloc Bristle Discs61
 - Super Scraper™61
 - Surface Conditioning Discs56
 - Tumbler Cleaning Media63
 - Ultrasonic Detergents & Filters65
 - Valve Stem Protectors61
- Parts Storage & Organizers**
 - DOHC Cylinder Head Tray67
 - Engine Cart67
 - FT-RACK7
 - Keeper-Keeper36, 61
 - Organizer Trays67, 135
 - Parts Tags & Marker68
 - Plastic Bags68
 - Safety Pins68
 - Seat Cutter Blade Rack7
 - Shrink Wrap68
 - VSI Storage Cabinet40
- Parts Tumbler Media**63
- Parts Tumbler Rebuild Kit**63
- Pastelub™ Hi-Temp Brake Lube**119
- Peening Tool**98
- Peterson**
 - Boring Bar Cutters70
 - Core Drills & Reamers22
 - Crankshaft Grinding Wheels97
 - Resurfacer Wheel Segments42
 - Single-piece Resurfacer Wheels44
- pH Tester**65
- Pilots**
 - Black & Decker Gruv-Top Pilots & Collets3
 - Expanding2
 - Extended Length Top Solid-Tapered2
 - Live2
 - Micro2, 3
 - Serdi-Style2
 - Solid-Tapered3
 - Split3
 - Tapered Carbide2
- Pin Pal Puller**91
- Piston Installing Tools**
 - Deadblow Hammer85
 - Electric Rod Heater87
 - Gas-Fired Rod Heater88
 - Piston Installing Sleeves85
- Piston Pin Installing Tools (cont.)**
 - Piston Pin Installing Fixture88
 - Ring Compressing Pliers85
 - Rod Clamping Vise88
- Piston Pin Removal Fixture**84
- Piston Ring Filer**86
- Plastigage**96
- Plateau Honers**76, 79
- Pneumatic Tools**
 - Air Hammer26
 - Scraper61
 - Valve Guide Drivers26, 27
 - Valve Spring Compressors34, 35
- Polishing Belts & Rouge**100, 101
- Portable Cylinder Honers**74
- Porting & Polishing**
 - Abrasive Flapwheels56, 57
 - Abrasives Kit57
 - Abrasive Rolls with Integral Mandrels57
 - Aluminum Oxide Cloth Shop Rolls56
 - Butterfly Mandrels56
 - Carbide Burr Set59
 - Crocus Cloth56
 - Cross-Buffs®56
 - Deluxe Porting Kit™57
 - Die Grinders57
 - Long Shank Carbide Rotary Files58
 - Mandrels56
 - Mounted Wheels58
 - Port Reshaping Kit57
 - Porting & Polishing Machining Aid56, 73
 - Replacement Abrasives and Mandrels56
 - Rotary Files58, 59
 - Small Engine Porting Kit57
- Powered Ring Filer**86
- Powersports (separate index follows)**
- Pre-Lube Tank**89
- Premium Tapered Reamers**108
- Pre-Oiler**89
- Press Fit Lubricant**26, 89
- Press Kit, Tapered Pin**83
- Pressure Lube**26, 89
- Pressure Tester Rust Inhibitor**51
- Pro Jet Spray Cleaner**65
- Profilometer**44, 121
- Pucks (VADs)**55
- Pumps**64
- Q**
- Quick Change Pad Holders**56
- Quick Couplers**77
- Quick Mount Bar Set**52
- R**
- Radial Wire Brushes**61
- Reamers**
 - Bronzwall30
 - Bronze23
 - Carbide Valve Guide23, 134
 - Cobalt23
 - Core22
 - Diesel22
 - High Speed for Cast Iron23
 - Piloted Core Reamers22
 - Small Diameter23, 134
 - Tapered108
 - Titanium Coated Cobalt23
- Reaming Oil**23, 30, 73
- Rear Main Seal Holders**92
- Rebuilding Kits**
 - Parts Tumbler63
 - Spring Compressor34, 35
 - Stone Holder18
- Reducing Bushings**30
- Reluctor Ring Installation Tool**103
- Replacement Belt for B&D Valve Refacer**109
- Resurfacing Belts**43
- Resurfacing Wheel Segments**42
- Resurfacing Wheels**44
- Resurfacing Coolant**43, 44, 73
- Resurfacing Dressers**44
- Resurfacing Spray**41, 73
- Ring Compressors**85
- Ring Expanders**86
- Ring Grinders**86
- Rocker Arm Tools**53
- Rockwell Hardness Tester**98
- Rod and Cap Grinding Wheels**81
- Rod Balancing Stand**99
- Rod Bolt Boots**88
- Rod Bolt Installing Block**88
- Rod Bolt Stretch Gauge**121
- Rod Clamping Vise**88
- Rod Heaters**87, 88
- Rod Hone Filter Mat**78
- Rod Honing Oil**73, 80
- Rod Honing Stones & Guide Shoes**80, 81
- Rod Hone Mandrels**80, 81
- Roll Over Fixture**52
- Roloc Bristle Discs**61
- Rotary Broach Tool Bits**43
- Rotary Files**58, 59
- Rottler**
 - Boring Bar Cutters70
 - Diamond Lap71
 - Sleeve Cutters70
 - Valve Refacer Wheels21
- Rust Protection**42, 64
- S**
- Safety Glasses**63, 66, 67
- Safety Pins**68
- Scales**99
- Scrapers**61, 94
- Scribe Tools**9
- Seal-All™**50
- Seals**33, 129
- Seal Cutters**32
- Seal Pullers**32
- Seal Setters**32
- Seat Cutters**4 - 8, 38
- Seat Cutting Fluid**8, 73
- Segments**42
- Serdi Style Pilots**2
- Serdi-Style Bodies & Drivers**4
- Shim Stock**54
- Shot**
 - Ceramic63
 - Glass62
 - Steel63
- Shop Towels**66
- Shrink Wrap**68
- Silencer Brake Spray**119
- Silencers**113
- Sioux™ Replacement Parts**
 - Parts Tumbler Rebuild Kit63

Wheel Dresser Pilots & Bushings.....	17
Valve Refacer Parts	109
Sioux-Style	
Drive Adaptor	18
Drivers.....	19
Pilots	2, 3
Stone Holders	18
Vacuum Plates	46
Valve Refacer Wheels	21
Valve Seat Stone Removers	18
Valve Seat Wheels	14 - 16, 19
Sizing Balls	29, 30
Sludge Filter Bag (Sock)	64
Smog Plugs	68
Snap-on	
Replacement Brake Lathe Cutting Tips	111
Valve Refacer Wheels	21
Valve Seat Stones	16
Spark Plug Thread Chaser	108
Speed Reducer	31
Spiramp®	31
Spot Facers	31, 53
Split Ball Bore Gauge	29, 123
Spray Welding Powder	51
Spring Compressors	34 - 37, 132
Spring Compressor Rebuild Kit	35
Spring Pad Cutters	8, 38
Spring Seat Cutting Tool	38
Spring Testers	39
Stamps, Steel	68, 102
Starrett	
Crankgrinder Dial Indicator	99
Levels	41
Steady Rest Shoes	99
Step Gauge	104
Stone Holders	18
Storage Bags	42, 68
Storage Cart	67
Storm-Vulcan	
Boring Bar Cutters	70
Crankshaft Grinding Wheels	97
GM Vortec Adaptor Plate Set	52
Resurfacer Wheel Segments	42
Resurfacing Carbide Cutter Tips	43
Straight Edges	54, 121
Stones	
Camshaft	93
Crankwheel.....	97
Flywheel	105
Honing	74 - 79
Porting & Polishing	58
Refacing	20, 21
Resurfacing	42, 44
Valve Seat	14 - 16
Stroker Mimic™	98
Stud Boss	53
Stud Extractor	53
Stud Pullers	53
Stud Stretchers	41
Sunnen®	
Align Hone Mandrels	79
Belts for Rod Honing Machines.....	80
Cap Grinding Wheels	81
Core Drills & Reamers	22
Cylinder Honing Stones	75 - 79
Dial Bore Gauges	125
Feed Rods	80

Sunnen®(cont.)	
Guide Shoes	80, 81
Honing Head for Rod Machines	80
Lifter Bore Hones	92
Main Bore Align Hone Mandrels	79
Mandrel Drivers	79
Master Holder & Stone Supports	75
Plateau Honing Tools, Ultra-Finish	76
Portable Cylinder Hones	74
Press-Fit Lubricant	26, 89
Quick Couplers	77
Replacement Parts for CV-616	78
Rod Chamfer Cutters.....	80
Rod Honing Stones & Guide Shoes	80, 81
Truing Sleeves	25, 81
Valve Guide Hone Set	25
Valve Refacer Wheels	21
Super Scraper™	61
Sure Shot® Sprayer	64
Surface Tester	44, 121
Surfacing	
Belts	43
CBN Inserts	41
Coolants	43, 44
PCD Inserts	41
Segments	42
Wheels	44
Swedge Cutting Tool	116
Switches	109, 114, 117
T	
Tapered Reamers (For Tie Rods, Bball Joints) ...	108
Tap Cleaner	51
Tapered Pin Bushing Kit	83
Tapping Fluid	8, 73
Taps	
Bronze-Wall	30
Crack Repair	51
Telescoping Gauge	121
Temperature Indicator Crayons	54, 88
Tensioner Stop Block	71
Thin Wall Bronze Liners	29
Timing Chain Tightener	71
Titanium Coated Cutting Tips	111
Tooling Stand	19, 38
Top Cutters	31, 53
Torque-Angle Indicator	53, 93
Torque Plates	71, 135
Trays, Organizing	67
Tumbling Media	63
U	
Ultra-Finish Plateau Honing Tools	76, 79
Ultrasonic Detergents & Filters	65
Universal Checking Standards	125
Universal Dressing Stands	17
Universal Seal Pliers	32
Universal Spring Pad Cutter	8
Utility Rolls	56
V	
V-Twin	
Double Head Plate	136
Harley Adaptor for Guide Driver	27
Head Plate & Stand	136
On-the-Engine Spring Compressor.....	132
Organizer Tray	87, 135

V-Twin (cont.)	
Torque Plates	135
V-Rod Spring Compressor Kit	37
Valve Guides.....	130
Valve Guide Reamers.....	134
Valve Seals	129
Valve Seat Cutter Blades	7
Valve Seat Inserts.....	129
Valve Springs	132, 133
Valves	127
Vacuum Plates	45, 46
Vacuum Testers	
Electric Vacuum Tester	46
Manual Vacuum Tester	46
Pistol Grip Vacuum Tester	45
VADs	55
Valve Adjustment Tools & Discs	55
Valve Grinding	
Adaptor for ½" Chucks	21
Black & Decker Valve Refacer Collets	21
Blinging Fluid	8, 13
Diamond Dresser Tools	107
Machine Parts	109
Valve Grinding Aid	20
Valve Grinding Oil	20, 73
Valve Refacer Wheels	20, 21
Valve Stem Concentricity Gauge	20
Valve Guide	
Bronze-Liners	28, 29
Bronze-Wall® & Bronze-Wall 2®	30
Brushes	24, 60
Core Drill / Reamer	22
Diamond Hone Set	24
Drivers	26, 27
Flex-Hones®	72
Gauge Set	29, 123
Guides	27, 127, 130
Hone Set	24, 25, 131
Knurling Tools	31
OD Chamfer Tool	34
OD Knurling Tool	31
Reamers	23, 134
Small Hole Gauge Set	29, 123
Spiramp Resizing Tool.....	31
Spot Facer	31
Top Collars	25
Top Cutters	31
Valve Guide Brushes	24, 60
Valve Lapping Tools & Supplies	13
Valve Refacing	
Wheels	20, 21
Diamond Dressers.....	107
Valve Seals	22, 33, 129
Valve Seal Work	
Cutters.....	32, 134
Pullers	32
Seal Setters	32, 129
Valve Seat	
Basic Valve Seat Grinding Kit	19
Bounce Springs	18
Bousfield Cutters.....	9
Cutter Blades	6, 7, 10
Cutter Drivers	5
Cutting Fluid	8, 73
Cutting System.....	4, 10, 11
Dressers	107
Drivers	12

Index

Valve Seat (cont.)	
Inserts	12, 129
Layout Fluid	8, 13
Machining Aid	9
Minnesota Fast Freeze	9, 84
Neway Seat Cutting System.....	10, 11
Nickel-Chrome Valve Seats	12
Prussian Blue Machining Paste	8, 13
Removers	5, 12
Run-Out Gauges	9, 123
Stone Holders	18
Valve & Seat Scribe	9
Valve Seat Wheels	14 - 16
Valve Seat Cutter Blades	6, 7, 10
Valve Seat Counterbore Cutters	12
Valve Seat Insert Driver	12
Valve Seat Wheels	14 - 16
Valve Spring	
Adaptors	36, 37
Calibrated Springs	39
Compressors	34 - 36, 132
Diesel Valve Spring Compressor	34
Inserts	40
Keeper Installation Tools	36
Manual Valve Spring Bench	35
Pneumatic Compressor Retrofit Unit	35
Pneumatic Valve Spring Press	34
Seat Cutter	8, 38
Spring & Retainer Kits.....	128, 132, 133
Testers	39
Valve Spring Inserts	40
Valve Stem	
Concentricity Gauge	20
Dial Indicator Valve Stem Height Gauge	38
Protectors.....	61
Valve Stem Oil Seals	22, 33, 129
Valve Seal Setter	32
Valve Seal Drivers	129
Valve Seal Pullers	32
Valves	126, 131
Van Norman	
Boring Bar Cutters & Parts.....	70
Core Drills & Reamers	22
Crankshaft Grinding Wheels	97
Flywheel Cutter	104
Replacement Brake Lathe Cutting Tips	111
Resurfacer Segments	42
Single-piece Resurfacer Wheels	44
Valve Refacer Wheels.....	21
Vertical Mill Roll-Over Fixture	52
Viton Valve Seals	33, 129
Vortec Tools	32, 52
W	
Way Oil	73
Welding	
Crank Welding Plugs	102
Spray Welding Powder	51
Wire Wheels & Brushes	61
Y	
Y-7 Crack Detection Yokes	48
Z	
Zinc Break-In Lube	89, 90

Powersports Index

A	
ATV Hard Parts	126 - 129
AV&V® Brand Hard Parts	127 - 133
B	
Beehive Valve Springs	133
Black Tulip® Valves	126, 131
C	
Chrome Tulip Valves	126, 131
Carbide Valve Guide Reamers	23, 134
Compression Release Valves	134
Cylinder Hone	74
D	
Degree Wheel	94
F	
Flex-Hones®	72
H	
Hard Parts	127 - 133
Head Organizer Tray	135
Head Plate & Stand	136
Honda Hard Parts	126 - 129
I	
Infinite Flow Cutting Tips	6
K	
Kawasaki Hard Parts	126 - 129
Keyway Honing Stone Sets	76
Kreative Flow Seat Cutters	6
M	
Manual Valve Spring Compressors	36, 37, 132
Micro Ball Head Tooling	5
Micro Valve Seat Wheels	14
Motorcycle Engine Hard Parts	127 - 133
N	
Neway Valve Seat Cutting System	10
O	
OE-Style Seals & Drivers	129
On-The-Engine Valve Spring Compressor	132
P	
Pilots	2, 3
Porting Kits	57
Powered Valve Guide Driver Adaptor	27
R	
Reamers	23, 134
S	
Small Diameter Portable Honing Set	74
Small Engine Porting Kit	57
Seat Cutters	134
Spring Seat Cutting Tool for Pan/Shovel	134
Suzuki Engine Hard Parts	126 - 129
T	
Torque Plates	71, 135
V	
Valve Guides	127, 130, 134
Valve Guide Reamers	23, 134
Valve Seal Cutter	134
Valve Seals	129
Valve Seat Cutter Blades	6, 7
Valve Seat Inserts	129
Valve Seat Stones	14 - 16
Valve Spring Compressors	34 - 36, 132
Valve Spring Inserts	128, 132, 133
Valve Train Hard Parts	126 - 129
Valves	126, 131
Y	
Yamaha Hard Parts	126, 129

Replacement Parts

Black & Decker

Gruv-Top Pilots & Collet.....	3
Chuck Belt	109
Valve Refacer Collets	109

Kwik-Way

Valve Grinder Parts	109
---------------------------	-----

Sioux™

Belts	109
Driver Parts	109
Parts Tumbler Rebuild Kit.....	63
Wheel Dresser	17
Vacuum Tester Gauge.....	109
Vacuum Tester Plates	46
Valve Refacer Parts	109

Sunnen®

CV-616 Honing Machine Belts & Gears.....	78
Rod Honing Machine Feed Rods	80
Rod Honing Machine Belts	80

Brake & Alignment Index

A

Abrasive Sleeves	114
Accu-Turn Replacement Parts	114, 117
Accu-Turn Tips	111
All Tool Tips	111
Ammco Replacement Parts	114 - 116
Ammco Style Drum Silencers	113
Ammco Tips	111
Alignment Tools	120
Arbor Nuts	114
Arbors	114
Automotive Adaptors	118

B

Ball Joint Gauge	120
Backing Plates	118
Bean Tips	111
Bean Replacement Parts	117
Bear Tips	111
Bell Clamps	119
Bits	111
Boring Bars & Clamps	115
Brake Lubes	119
Brake Caliper Flex-Hones®	117
Brake Fluid Test Strips	117
Brake Lathe Chatter Eliminators	113
Brake Lathe Cutting Tips	111
Brake Lathe Tip Holders	112
Brass Wear Inserts	115
Brazed Carbide Cutting Tools	113

C

Captured Rotor Adaptor	119
Carbide Brake Lathe Tips	111
Caster/Camber Bubble Gauge	120
Caster/Camber Cam Bolt Kit	120
Centering Cones	118, 119
Centering Springs	114, 119
Ceramlub™	119
Chain Silencer	113
Chip Shield for Ammco	115
Clamp On Silencers	113
Cross Feed Dust Boots	116
Cross Feed Shear Gear	115, 116

D

Disc Rotor & Ball Joint Gauges	120
Double Duty tip Holders	112, 115
Double Tapered Centering Cones	118
Drive Pulley & Belts	116
Drum Micrometer	121
Drum Feed Screws & Nuts	115, 117
Duck Heads	119
Dust Boots	116

E

Electronic Digital Gauges	121
Expansion Assemblies	115

F

Ford F-150 Mounting Adaptor	119
Feed Motor	117
Flex-Hones®	117
Flexible Arbor Spacers	114
FMC Replacement Parts	117
FMC Tips	111
Friction Silencers	113

H

Hardspot Cutters	113
Hoffman Tips	111
Honed Edge Tips	111
Horvath Tips	111
Hubless Rotor Mounting Set	118
Hunter Tips	111

K

Kwik-Way Tips	111
---------------------	-----

L

Late Model Rotor Adaptor	119
Lead Screw Bushing	115
Locking Knob	115

M

Magnetic Strap Silencers	113
Micro Ball Head Tooling	5
Micro Valve Seat Wheels	14
Motorcycle Engine Hard Parts	127 - 133

N

Neoprene Brake Lathe Silencer	113
Neoprene Spindle Boot	116

P

Pastelub™	119
Performance Tips	111
Pro-Cut Tips	111

Q

Quick Chuck Mounting Adaptor Set	118
--	-----

R

Right Angle Drive Assembly	114
Rotor Adaptors	119
Rotor Feed Screws	115, 117
Rotor Micrometers	120
Rotor Silencers	113
Round Brake Lathe Tips	111
RTI Tips	111
Rubber Spindle Boots	116
Rubber Strap Silencers	113

S

Screw Feed Dust Boots	116
Seals	115
Serpentine Drive Belts	116
Silencer Brake Spray	119
Silencer Bands	113
Snap-On Tips	111
Spacers	114
Spindle Boots	116
Springs	114, 119
Strip Dip™	117
Swedge Cutting Tool	116
Switches	114, 117

T

Tie Rod Stabilizer	120
Tip Holders	112
Tips	111
Tire Changer Mounting Heads	119
Titanium Coated Tips	111
Tool Bit Holders	115
Tooling Hold Down Pieces	115
Truck Adaptor Sets	119
Twin Cutter Head	115

U

Universal Adaptor Plus System	118
Universal Wheel Clamp	120

V

Van Norman & Rels Tips	111
Variable Speed Motor	117
VBG Tips	111

W

Way Assembly	117
Wear Inserts	115

Policies

Pricing:

Prices are subject to change without notice. There is no minimum order. Orders are billed at the prices in effect at the time of shipping. Discounts are not available on Sunner® products.

Shipping:

Goodson ships orders the same day they are received. Orders received after hours, on weekends or holidays are shipped the next business day.

You have several choices of shipping speed as explained below.



■ **STANDARD:** Unless otherwise requested, we ship items up to 150 lbs. and up to 130" in combined width, length and height by UPS or FedEx services. Items over the weight or size limit must go by common carrier. Dimensional weights may apply.

■ **EXPRESS:** We can ship most items by air to arrive in your choice of 1, 2 or 3 days.

If your order is lost in shipping, Goodson works with the shipper to provide tracking service.

Please be sure to inspect all shipments immediately and report damage or errors as soon as possible.

Freight:

For orders shipped ground within the USA, you may deduct the freight charges on any **jobber** net invoice of \$800 or more if you pay within 30 days. *However, Glass Beads, Steel Shot, Tumbler Media, Machines, Equipment, Bulk Liquids and Crankwheels are not included* (shipped F.O.B. Winona, MN). Hazardous Materials, Dangerous Goods and Dimensional Shipping fees may apply on certain items. Please call to inquire.

Terms:

- 1) A 1% discount is given on merchandise if payment is made within 15 days from invoice date. This discount applies to the merchandise amount only (not the total amount) on the invoice (not a statement). The discount amount is shown in the lower left hand corner of the invoice. This discount does not apply to statement payments and does not apply to credit card orders.
- 2) Invoices not paid in full within 30 days from the statement date are subject to a finance charge of 1.5% per month (18% per year).



Credit & Debit Card Orders:

Goodson accepts MasterCard, Visa, American Express and Discover Card. For your security, credit card numbers are **NOT** kept on file.

Check Acceptance:

In the unlikely event that your check is returned for insufficient or held funds, we will debit your checking account electronically for the face amount of the check plus the service fee allowed by your state's law. This allows us to resolve the problem without turning you over to a collection agency and harming your credit rating. The transaction will appear on your bank statement and no one will have to contact you about payment.

Returns:

You may return any item, *except special orders*, **within 60 days**. We will do our best to correct any problems or to send a replacement. If an item was damaged through mis-use or modification, Goodson will not accept it as a return. Credits will only be issued after it is

determined that the part is resalable or it is deemed defective. To return an item, please follow these easy steps:

1. Enclose a note explaining why you're returning the product. Be sure to include your name and account number (you'll find this on your invoice)
2. Ship the item freight prepaid within 60 days from invoice date to **Goodson Tools & Supplies for Engine Builders**
ATTN: Returns
156 Galewski Drive
Winona, MN 55987

For best results, please ship return merchandise by UPS or Federal Express. Keep your receipt as it may be necessary to track the package if it is lost in transit. A 10% restocking fee applies on all returns unless the problem was the fault of Goodson. If so, the restocking fee is waived and shipping costs are reimbursed.

ABRASIVES WARRANTY: Abrasives have a shelf-life, therefore, all abrasives are warranted against manufacturing defects for 1 year from the date of original purchase.

Privacy Policy:

All information that Goodson collects from its customers through purchases, credit applications or other transactions is kept private and is not disclosed to anyone except as permitted by law. Goodson will not sell or trade this information to anyone. Goodson will limit employee access to customers' private information to only those employees who need to know the information to provide products and services to you. Goodson maintains internal safeguards to protect our customer's non-public information. Please see our website www.goodson.com/privacy_policy.php for details.



International Sales:

All items shipped F.O.B. Winona, MN, USA. To find the distributors in your country, visit www.goodson.com.

Goodson currently has distributors in:

- Australia • Bolivia • Canada • Chile • Colombia • Costa Rica
- Ecuador • El Salvador • Finland • Germany • Guatemala
- Honduras • Italy • Malaysia • Mexico • Netherlands • New Zealand
- Peru • Poland • Puerto Rico • Singapore
- Suriname • Sweden
- Switzerland • Turkey
- United Kingdom
- Venezuela



Do you have the next great engine building tool?

Would you like to have Goodson bring it to market for you?

Some of our best tools have come from machinists, just like you, who have found a better or faster way of doing something. If you'd like to discuss your "great idea" call Dave Monyhan (800-533-8010) or send an email to dave@goodson.com.

Take advantage of these quantity discounts!



Look for this symbol throughout the book for items that have price breaks based on the quantity that you buy. It's a great way to save money and have adequate stock on hand.

I'm back and I'm hiding in the catalog. Can you find me?

When you find me, call **1-800-533-8010** with my location and you'll win a prize. Hurry, my location will be revealed in the Goodson blog at the end of May 2012.



Flywheel Grinding Stones

Order 5 or more (any combination) and save 10% off jobber, see pages 104-105



Valve Seat Wheels

Order 10 or more seat wheels (any combination) and save 10% off jobber, see pages 14-16



Crankshaft Polishing Belts

Order 5 or more boxes of belts (any combination) and save 10% off jobber, see pages 100-101

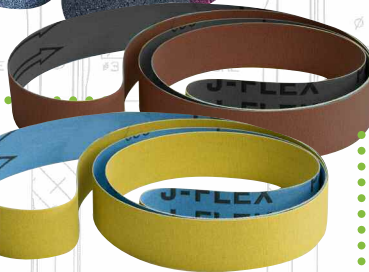

Cylinder Head Resurfacing Wheel Segments

Buy a complete set of 8 or more and save 10% off jobber, see page 42



Brake Lathe Replacement Cutting Tips

Order 3 or more 10-Packs (mix & match) and save 10% off jobber, see page 111

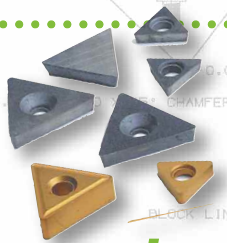

3" or 5" Chamfering Cones

Order 5 or more (mix & match) and save 10% off jobber, see page 77



Goodson Brand HN-Cylinder Honing Stones

Order 5 or more sets and save 10% off jobber, see page 75



Valve Guides Cast Iron or Manganese Bronze

Order 50 - 100 guides and save 10% off jobber, Order 100 or more and save 20% off jobber, (mix & match sizes) see page 27



Valve Stem Oil Seals

Order 3 or more boxes (mix & match) and save 10% off jobber, see page 33

End Brushes

Order 5 or more and save 10% off jobber. Order 15 or more and save 15% off jobber. Mix & match styles and sizes, see page 60



Last Blast Spray Paint

Buy a case of 12 (mix & match) and save 15% off jobber, see page 69



GOODSON

Tools and Supplies for Engine Builders

156 Galewski Drive • P.O. Box 847 • Winona, MN 55987-0847

Source Code

Account Number

Easy Toll-Free Ordering by Phone
1-800-533-8010

Toll-Free Fax 24-Hours a Day
1-888-466-3909

Order Online!
www.goodson.com



GOODSON

Tools and Supplies for Engine Builders

156 Galewski Drive • P.O. Box 847 • Winona, MN 55987-0847

**Designing
and
manufacturing
products to make
engine building
faster and easier
since 1945**

MFG TO CRUSH BEARING CAP ERROR PROOFING DIMPLES AS INDICATED

MFG TO CRUSH BEARING CAP ERROR PROOFING DIMPLES AS INDICATED

MFG TO CRUSH BEARING CAP ERROR PROOFING DIMPLES AS INDICATED

19.0 ZONE
4.0 ± 1.0 H
0.2 mm MAX
(5) PLACES

(5) PLACES

